

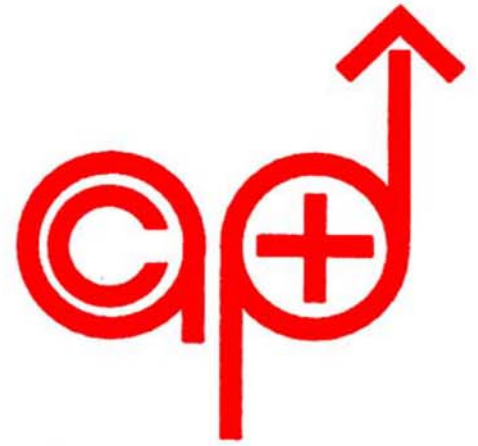

Software Hardware Systems



ACP&D Limited

MANUAL

**STEPPING MOTOR DRIVER
SERIES**

STAR 2000

Mod.

ET1000

APSx-B-0P/D28

APSx-B-0P/S48

APSx-B-0P/S41

LABELLING MACHINE CONTROL

SOFTWARE

RELEASE 54FW2E (encoder less)

RELEASE 54FW2G - 54FW4E (encoder)

SUMMARY:

1. DRIVE CONNECTIONS LAYOUT	Pag. 4
2. OPERATION DESCRIPTION	Pag. 5
3. CURRENT REGULATION	Pag. 6
4. SPEED REGULATION	Pag. 7
- speed regulation using external potentiometer	
- speed regulation using internal trimmer	
- encoder synchronisation (rel 54FW2G only)	
- recommended encoder (rel 54FW2G only)	
5. ACCELERATION RAMP SETTING	Pag. 8
6. STOP DELAY SETTING	Pag. 8
7. MOTOR STEPS DIVISION SETTING	Pag. 8
8. START/STOP MODE SETTING	Pag. 9
9. PROTECTION	Pag. 9
10. CARD LAYOUT	Pag.10
11. ELECTRIC CHARACTERISTICS	Pag.11
12. INPUTS/OUTPUTS	Pag.12
13. INPUTS/OUTPUTS CONNECTIONS	Pag.13
- features	
- functions	
- enable/disable	
14. MECHANICAL DIMENSIONS	Pag.14
15. DIP_SWITCHES TABLE / ET1000 HARDWARE VERSIONS	Pag.15

1. DRIVE CONNECTIONS LAYOUT

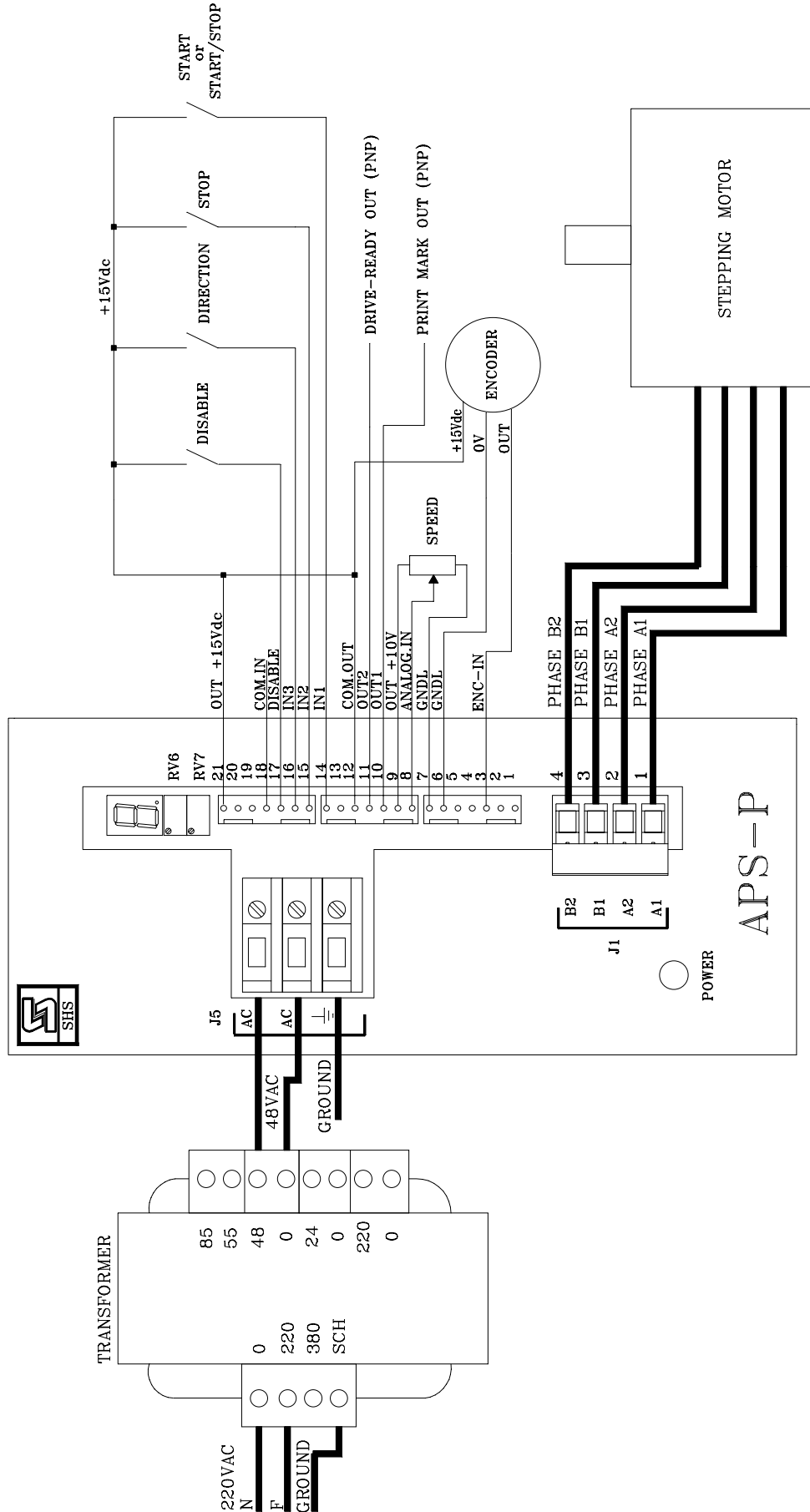

2. OPERATION DESCRIPTION

This driver has been projected to controll labelling machines.

By setting the START input (product presence) the motor start rotation, till STOP input is detected.

When the STOP is detected the motion will stops after n steps (settings by DIP-SWITCHES A 1 e 2).

At the end of motion the PRINT MARK OUTPUT is activate for 200 ms.

DISABLE input switch off the motor current.

DIRECTION input select the motor direction.

The current is setting by RV6 Trimmer (see chapter 3).

Supply speed is adusted by an external potentiometer or true RV7 trimmer (see chapter 4).

Acceleration ramp is setted using dip-switches (see chapter 4).

The motor steps division are setting by dip switches (see chapter 7).

While the motor is not running current is automatically riduced at 50% in relation to te setted value.

If the STOP sensor is not detected in 10 motor revolutions the motor stops automatically (paper broken).

This function is active after second START.

Is possible to synchronize the speed using an external encoder (see chapter 4).

3. CURRENT REGULATION:

For setting current proceed as follows:

- Set dip-switch B-4 to ON (current regulation mode).
- Turn RV6 trimmer until display shows the required current (CW to increase).
- Regulation field: from 1A to 10 A at steps of 0.5A for APS3/APS5 drive.
Regulation field: from 1A to 12 A at steps of 0.5A for APS4 drive.
Regulation field: from 1A to 6 A at steps of 0.5A for APS2 drive.
Regulation field: from 0.4A to 4 A at steps of 0.2A for APS1 drive.
- Set dip-switch B-4 to OFF (Run mode).

Table for setting current values and relating values shown on the display of drive APS:

DISPLAYED VALUE	SETTING CURRENT APS 1	SETTING CURRENT APS 2	SETTING CURRENT APS4	SETTING CURRENT APS 3 / APS5
1	0.4 A	1.0 A	1.0 A	1.0 A
1.	0.6 A	1.5 A	1.5 A	1.5 A
2	0.8 A	2.0 A	2.0 A	2.0 A
2.	1.0 A	2.5 A	2.5 A	2.5 A
3	1.2 A	3.0 A	3.0 A	3.0 A
3.	1.4 A	3.5 A	3.5 A	3.5 A
4	1.6 A	4.0 A	4.0 A	4.0 A
4.	1.8 A	4.5 A	4.5 A	4.5 A
5	2.0 A	5.0 A	5.0 A	5.0 A
5.	2.2 A	5.5 A	5.5 A	5.5 A
6	2.4 A	6.0 A	6.0 A	6.0 A
6.	2.6 A	-	6.5 A	6.5 A
7	2.8 A	-	7.0A	7.0A
7.	3.0 A	-	7.5 A	7.5 A
8	3.2 A	-	8.0 A	8.0 A
8.	3.4 A	-	8.5 A	8.5 A
9	3.6 A	-	9.0 A	9.0 A
9.	3.8 A	-	9.5 A	9.5 A
0	4.0 A	-	10.0 A	10.0 A
0.	-	-	10.5 A	-
a	-	-	11.0 A	-
a.	-	-	11.5 A	-
b	-	-	12.0 A	-

NOTE: ADJUST CURRENT WHEN MOTOR IS HOLDING.

4. SPEED REGULATION

- speed regulation using external potentiometer

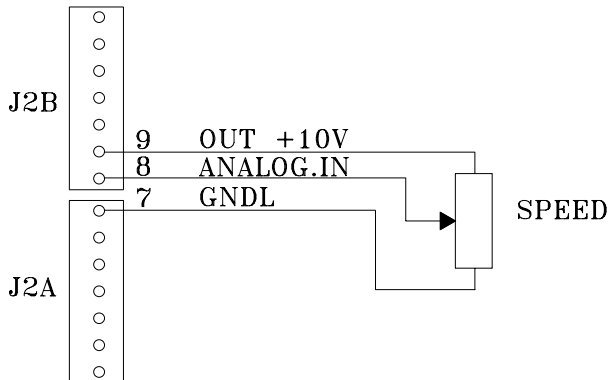

1. Set DIPB-1 OFF .
2. Connect the potentiometer (10K Ω) see picture.
3. Maximal speed setting:
 - Rotate the potentiometer to full scale in CW direction potentiometer (top speed).
 - Adjust RV7 trimmer until reach the needed top speed.

After these operations, true the external potentiometer is possible to set the speed from minimum speed to top speed.

- speed regulation using internal trimmer

1. Set DIPB-1 OFF .
2. make a bridge from pin 8 and pin 9 on J2B.
3. adjust the speed using RV7.

- encoder synchronisation (rel 54FW2G only)

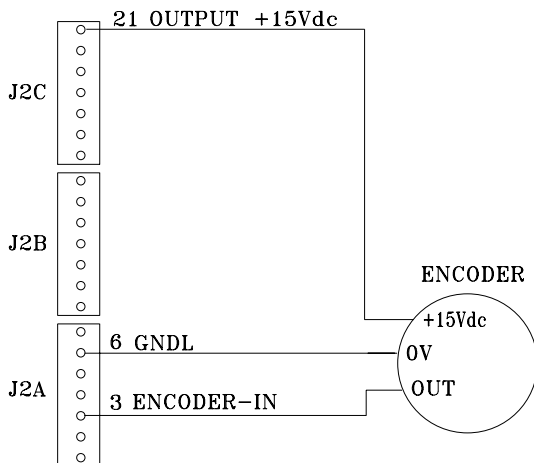

1. Set DIPB-1 ON.
 2. Connect the encoder to detect speed as show in picture.
 3. Adjust RV7 up to reach the synchronisation between the label supply speed and product speed.
- Recommended encoder:
- Maximum frequency 4KHz (1000 ppr)
 - OUTPUT NPN or totem-pole.
 - Power supply 15Vdc

5. ACCELERATION RAMP SETTING

To set the acceleration ramp use DIP SWITCHES A 4,5,6.
It possible select value from 0 ms (no ramp) up to 1 s:

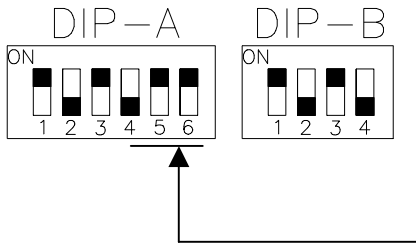

DIP A 4	DIP A 5	DIP A 6	RAMP [ms]
OFF	OFF	OFF	0
OFF	OFF	ON	10
OFF	ON	OFF	30
OFF	ON	ON	80
ON	OFF	OFF	150
ON	OFF	ON	300
ON	ON	OFF	500
ON	ON	ON	1000

The ramp is the value to reach the top.

6. STOP DELAY SETTING

To set the stop delay DIP SWITCHES A 1 e 2.
It is possible select value from 8 up to 64 motor steps:

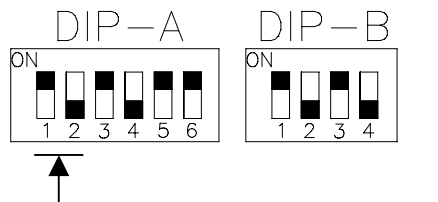

DIP A 1	DIP A 2	STOP DELAY
OFF	OFF	8
OFF	ON	16
ON	OFF	32
ON	ON	64

This function is active only in START / STOP mode with separate input (DIPA3 OFF).

7. MOTOR STEPS DIVISION SETTING

To set motor steps division use DIP-SWITCHES B 2 and 3:

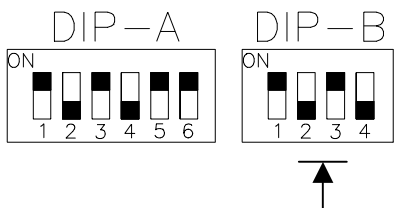

DIP B 2	DIP B 3	Motor resolution
ON	OFF	200 steps/rev. – full
ON	ON	400 steps/rev. – half
OFF	OFF	800 steps/rev. – 1/4
OFF	ON	1600 steps/rev. – 1/8

8. START/STOP MODE SETTING

To set START/STOP mode use DIP-SWITCH A-3:

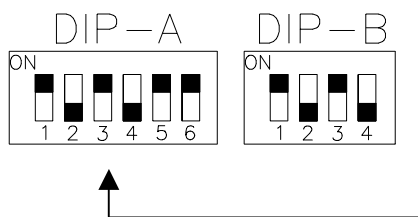

DIP A 3	START STOP MODE
ON	Start e stop one input: IN1 (J2-14) → START/STOP
OFF	Start e stop separate: IN1 (J2-14) → START IN2 (J2-15) → STOP

One input mode (DIPA3 ON) the acceleration rampa will be the same of deceleration ramp.

9. PROTECTION

The driver is protected against over temperature, over voltage, under voltage, short circuit. If a error condiction is detected, the driver switch off the power state and display the error condition code:

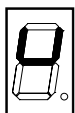

'u' – input voltage not right (under or over voltage)

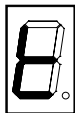

't' - thermal protection

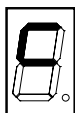

'c' – current overflow

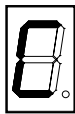

'C' – Paper broken

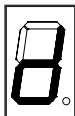

'd' – DISABLE input active

Driver ok 'r' (ready).

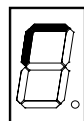

10. CARD LAYOUT

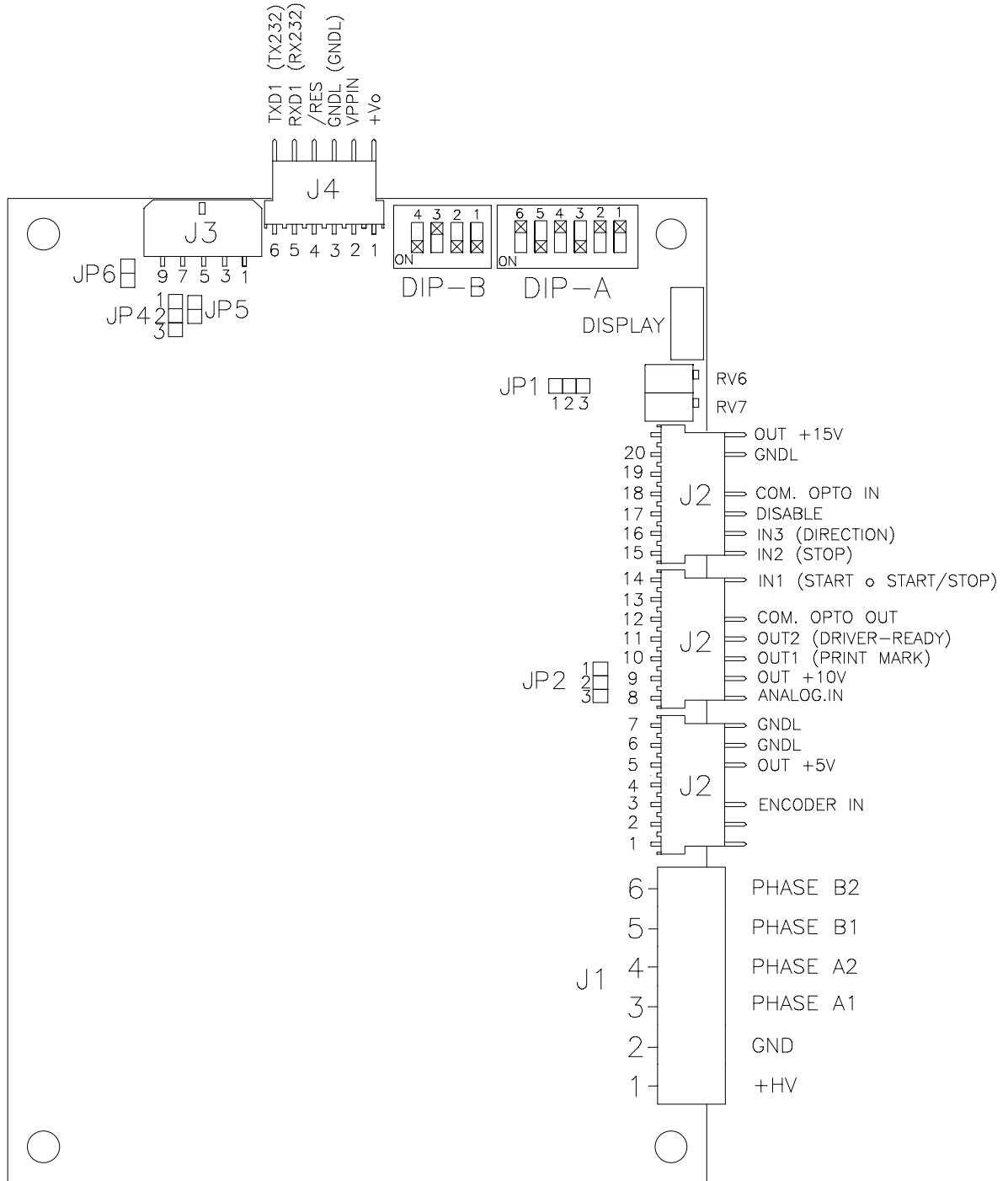

S.H.S. S.r.l. RESCALDINA (MI)
ITALY

TOLERANCES	TITLE	APS/D28 LAYOUT		
	DRAWN BY	VIGNATI	DATE	16.07.02
SCALE:	FILE NAME	S00-D28C	REV	1.0

11. TECHNICAL DATA

POWER SUPPLY/OUTPUT CURRENT

SIZE		APS1	APS2	APS3	APS4	APS5
Vdc nom.	[V]	From 40 to 80	From 40 to 80	From 40 to 80	From 80 to 140	From 160 to 180
Vdc max.	[V]	90	90	90	155	195
Vdc min.	[V]	30	30	30	75	155
I max.	[A]	4	6	10	12	10
I min.	[A]	0.4	1	1	1	1
I step	[A]	0.2	0.5	0.5	0.5	0.5
Operating temperature	[°C]	0-55	0-55	0-55	0-55	0-55

PARAMETERS DESCRIPTION

- VDC nom.:** Rated value of voltage by which the drive can be powered.
- VDC max.:** Maximum voltage at which the drive can operate. Over this limit, the protection of maximum voltage inhibits the drive.
- VDC min.:** Minimum voltage at which the drive can operate. Under this limit, the protection of minimum voltage inhibits the drive.
- I max.:** Maximum value of phase current.
- I min.:** Minimum value of phase current.
- I step:** Spacing of the current values.
- Operation temperature:** For any current over 6 Amps, a forced ventilation is necessary.

12. INPUT / OUTPUT:

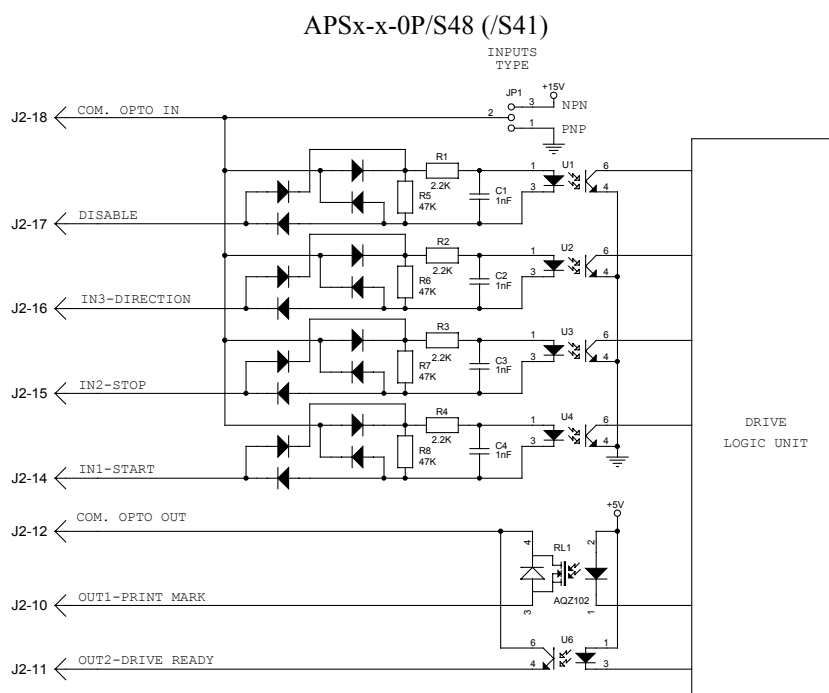
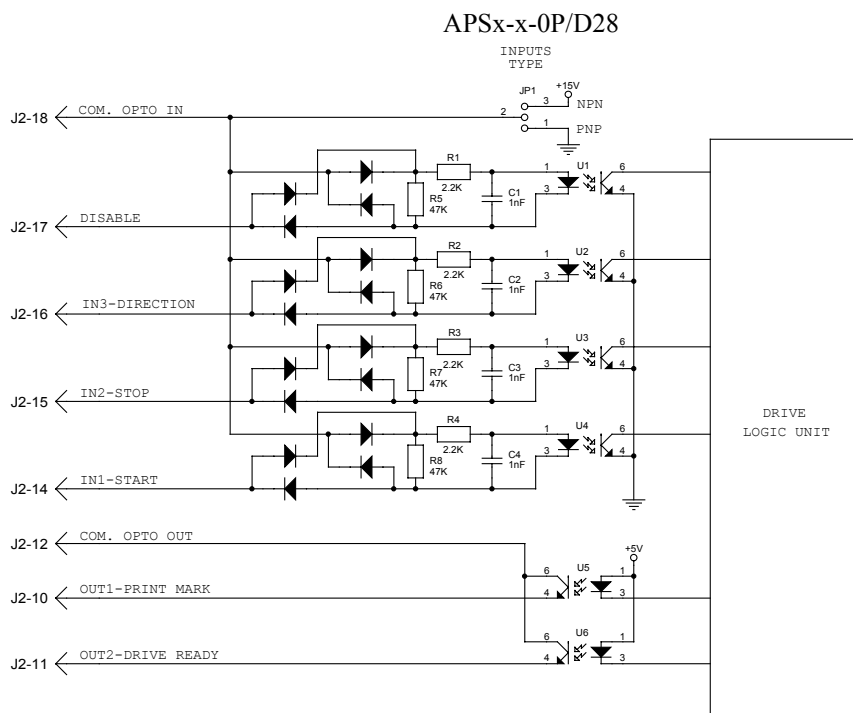

INPUTS/OUTPUTS CONNECTIONS

NOT OPTOISOLATED INPUT	
JUMPER	
Inserted on 1-2 pins	Input PNP : Connect external GND to J2 pin 6
Inserted on 2-3 pins	Input NPN : Connect external GND to J2 pin 6
OPTOISOLATED INPUT	
JUMPER	
Not inserted	Input PNP : Connect external GND to J2 pin 6
Not inserted	Input NPN : Connect external +12V or 24V to J2 pin 6

INPUT / OUTPUT FEATURES:

Inputs are PNP or NPN, outputs are PNP open collector optoisolated.

INPUTS:

INPUT VOLTAGE	IN1 HIGH SPEED INPUT	IN2, IN3, ENABLE INPUTS
LOW LEVEL	From 0 V to 8 V	From 0 V to 2.5 V
HIGH LEVEL	From 11 V to 30 V	From 4.6 V to 30 V

INPUT SIGNALS:

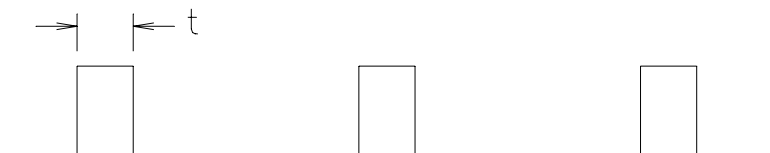

HIGH SPEED INPUT (IN1) : Min. impulse width $t=5$ ms

OTHER INPUTS : Min. impulse width $t=5$ ms

OUTPUTS:

OUTPUT VOLTAGE	Load 10mA (out with optoisolator)	Load 3A (out with static relays)
OUT ON		
COM.OPTO-OUT=12V	11.5 V	11.5 V
COM.OPTO-OUT=24V	23.5 V	23.5 V
OUT OFF	0 V	0 V

INPUT / OUTPUT FUNCTION

INPUTS:

SIGNAL	FUNCTION
START <i>IN1 (J2-14)</i>	Edge OFF - ON : Start rotation. Edge ON - OFF : DIPA-3 ON Stop rotation after n steps. : DIPA-3 OFF Not used.
STOP <i>IN2 (J2-15)</i>	Edge OFF - ON : DIPA-3 OFF Stop rotation with n brake steps : DIPA-3 ON Not used.
DIRECTION <i>IN3 (J2-16)</i>	ON : CW OFF : CCW
DISABLE <i>(J2-17)</i>	ON : Disable (motor current =0), OFF : power enable

ON=Input active

OFF=Input not active

OUTPUTS:

SIGNAL	FUNCTION
<i>OUT1 (J2-10)</i> PRINT MARK	After STOP this output will be activate for 200 ms.
<i>OUT2 (J2-11)</i> DRIVE-READY	ON : Drive ready OFF: Drive ready or paper broken (see letter on display)

14. MECHANICAL DIMENSIONS

APS1-P - APS2-P - APS3-P:

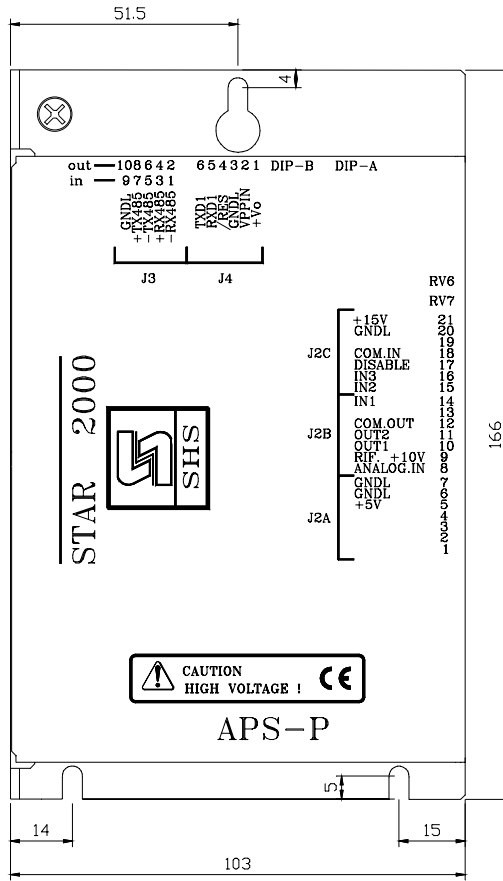
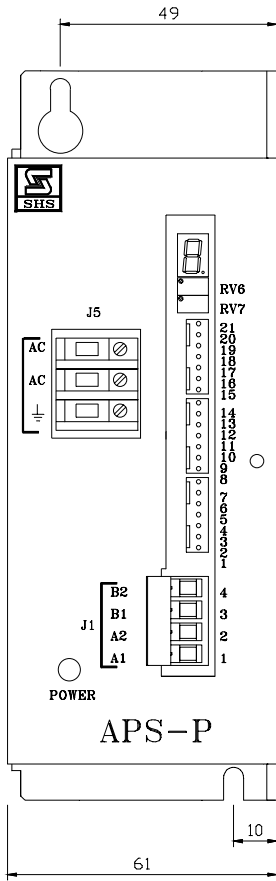

APS4-P:

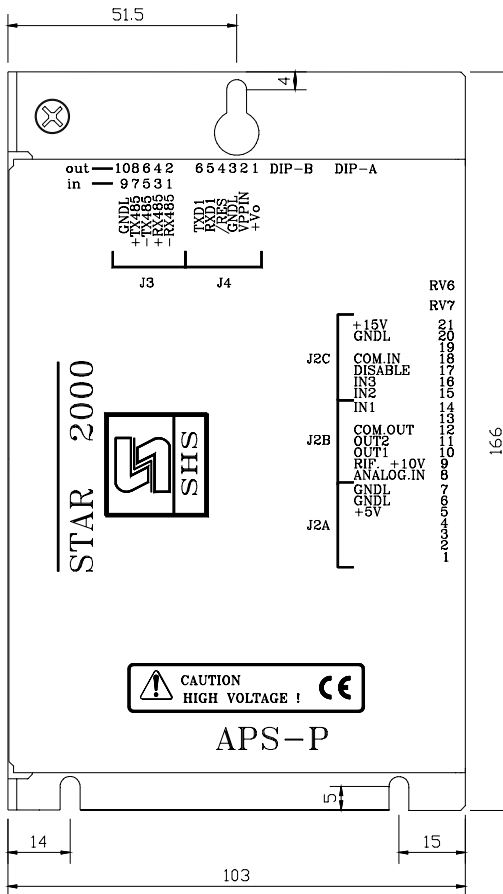
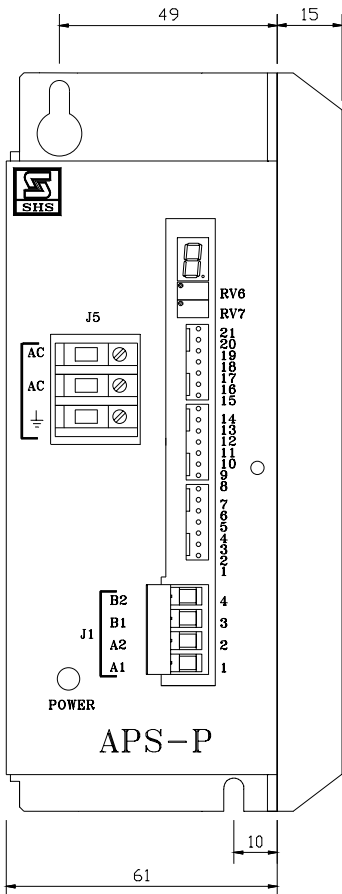

15. DIP_SWITCHES TABLE

DIP SWITCH A		
DIP	ON	OFF
6	Set ramp	Stop delay set
5	Set ramp	Stop delay set
4	Set ramp	Stop delay set
3	START/STOP single input	START and STOP separate
2	Stop delay set	Stop delay set
1	Stop delay set	Stop delay set

DIP SWITCH B		
DIP	ON	OFF
4	Current sets	RUN MODE
3	Motor resolution	Motor resolution
2	Motor resolution	Motor resolution
1	Encoder syncro active	Encoder syncro not active

ET1000 HARDWARE VERSIONS:

APSx-B-0P/D28 – outputs (OUT1, OUT2) pnp with optoisolators (max 10 mA)

APSx-B-0P/S48 – PRINT MARK (OUT1) with static relays (max 3 A),
READY-OUT (OUT2) with optoisolators (max 10mA)

APSx-B-0P/S41 – PRINT MARK (OUT1) with static relays (max 3 A),
READY-OUT (OUT2) with optoisolators (max 10mA)
Special heatsink mod. 02MCC001

ACP&D Limited

86 Rose Hill Road,
Ashton-under-Lyne,
Lancashire,
England,
OL6 8YF.

Tel: +44 (0)161 343 1884
Fax: +44 (0)161 343 7773
e-mail: sales@acpd.co.uk
Websites: www.acpd.com &
www.acpd.co.uk

