



micromaster



MICROMASTER 410/420/430/440
Inverters
0.12 kW to 250 kW



SIEMENS

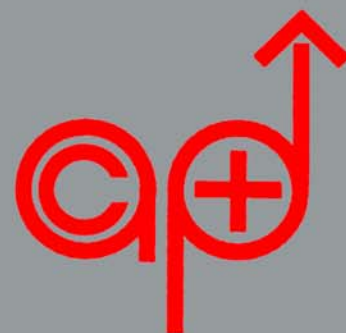

ACP&D Limited

Related catalogs

SINAMICS G110

Converter Chassis Units
0.12 kW (0.16 HP) to
3 kW (4 HP)
Order No.:

German: E86060-K5511-A111-A2
English: E86060-K5511-A111-A2-7600

D 11.1

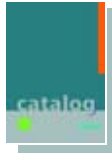

SINAMICS G130

Converter Chassis Units

SINAMICS G150
Converter Cabinet Units

Order No.:

German: E86060-K5511-A101-A3
English: E86060-K5511-A101-A3-7600

D 11

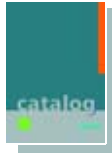

MICROMASTER/COMBIMASTER

MICROMASTER 411 Inverters
Distributed Drive Solutions
COMBIMASTER 411

Order No.:

German: E86060-K5251-A131-A2
English: E86060-K5251-A131-A2-7600

DA 51.3

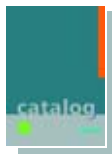

Industrial Communication

for Automation and Drives
Part 6: Distributed I/Os ET 200
Frequency Converter ET 200S FC

Order No.:

E86060-K6710-A101-B4-7600

IK PI

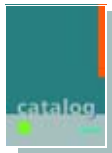

Low-Voltage Motors

M 11

Order No.:

German: E86060-K1711-A101-A3
English: E86060-K1711-A101-A3-7600

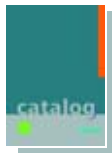

Geared Motors

Helical, Flat, Bevel-helical,
Helical-worm
and Worm Geared Motors

Order No.:

E86060-K1715-A101-A5
(available in German only)

M 15

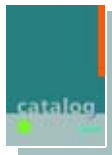

Catalog CA 01

The Offline Mall of Automation and Drives

Order No.:

CD-ROM: E86060-D4001-A100-C4 (Germ.)

CD-ROM: E86060-D4001-A110-C4-7600 (Engl.)

DVD: E86060-D4001-A500-C4 (Germ.)

CA 01



A&D Mall

Internet:

<http://www.siemens.com/automation/mall>



Catalog CA 01 – SD configurator selection aid

The **SD configurator** selection aid will be available in combination with the CA 01 electronic catalog.



On CD 2 of the selection and configuration aids you will find the SD configurator for low-voltage motors, MICROMASTER 4 inverters, inverter chassis units SINAMICS G110 and frequency converters for distributed I/Os SIMATIC ET 200S FC including:

- Dimension drawing generator for motors
- Data sheet generator for motors
- Starting calculation
- 3D models in .stp format
- Extensive documentation

Hardware and software requirements

- PC with Pentium II or comparable processor
- Operating systems
 - Windows 98/ME
 - Windows 2000
 - Windows XP
 - Windows NT (Service Pack 5 upwards)
- Minimum of 128 RAM
- 1024 x 768 graphics with more than 256 colors / small fonts
- CD-ROM drive
- Windows-compatible sound card
- Windows-compatible mouse

Installation

You can install this catalog directly from the CD-ROM as a complete or partial version on your hard disk or in the network.

Hotline:

For technical advice and hotline support concerning our CA 01 catalog:

Tel.: +49 (0) 180 50 50 22 2

E-Mail: adsupport@siemens.com

Trademarks

All product designations may be trademarks or product names of Siemens AG or supplier companies whose use by third parties for their own purposes could violate the rights of the owners.

MICROMASTER 410/420/430/440 Inverters 0.12 kW to 250 kW Catalog DA 51.2 2005/2006



Supersedes:
Catalog DA 51.2 · 2003/2004

The products in this catalog are also included
in the CD-ROM catalog CA 01.
Order No.:
E86060-D4001-A110-C4-7600 (CD-ROM)

Contact your local Siemens representative
for further information

© Siemens AG 2005



The products and systems described in this catalog are manufactured/distributed under application of a certified quality management system in accordance with DIN EN ISO 9001 (Certified Registration No. 000357 QM) and DIN EN ISO 14001 (Certified Registration No. 081342 UM and EMS 57390). The certificate is recognized by all IQNet countries.



SIEMENS

Overview

Welcome to
Automation and Drives
Selection guide
MICROMASTER inverters
Overview of options

MICROMASTER 410 “The low-priced”

0.12 kW to 0.75 kW

MICROMASTER 420 “The universal”

0.12 kW to 11 kW

MICROMASTER 430 “The specialist for pumps and fans”

7.5 kW to 250 kW

MICROMASTER 440 “The all-purpose”

0.12 kW to 250 kW

Appendix

Certificates/Standards
Demonstration case/
Training
Overview of motors and
inverters
Siemens contacts
Online services
Service & Support
Conditions of sale and
delivery
Export regulations

0

1

2

3

4

A

Welcome to Automation and Drives



We would like to welcome you to Automation and Drives and our comprehensive range of products, systems, solutions and services for production and process automation and building technology worldwide.

With Totally Integrated Automation and Totally Integrated Power, we deliver solution platforms based on standards that offer you a considerable savings potential.

Discover the world of our technology now. If you need more detailed information, please contact one of your regional Siemens partners.

They will be glad to assist you.



Totally Integrated Automation – innovations for more productivity

With the launch of Totally Integrated Automation, we were the first ones on the market to consistently implement the trend from equipment to an integrated automation solution, and have continuously improved the system ever since.

Whether your industry is process- and production-oriented or a hybrid, Totally Integrated Automation is a unique “common solution” platform that covers all the sectors.

Totally Integrated Automation is an integrated platform for the entire production line - from receiving to technical processing

ERP
Enterprise
Resource
Planning



Ethernet

MES
Manufacturing
Execution
Systems

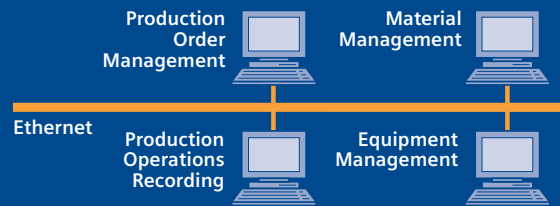

Control

SIMATIC NET
Industrial
Communication

**SINAUT Telecontrol
System**

**SIMATIC
Software**

**SIMATIC
Machine Vision**

**Industrial Wireless
Communication/
MOBIC**

Safety Integrated

PC-based Automation

**Building
Technology**

**Micro-Automation and
Actuator-Sensor
Interface Level**

**ECOFAST IP65
Distributed
Automation System**



Industrial
Ethernet



PROFIBUS



AS-Interface



GAMMA *instabus*

and production areas to shipping. Thanks to the system-oriented engineering environment, integrated, open communications as well as intelligent diagnostics options, your plant now benefits in every phase of the life cycle.

In fact, to this day we are the only company worldwide that can offer a control system based on an integrated platform for both the production and process industry.

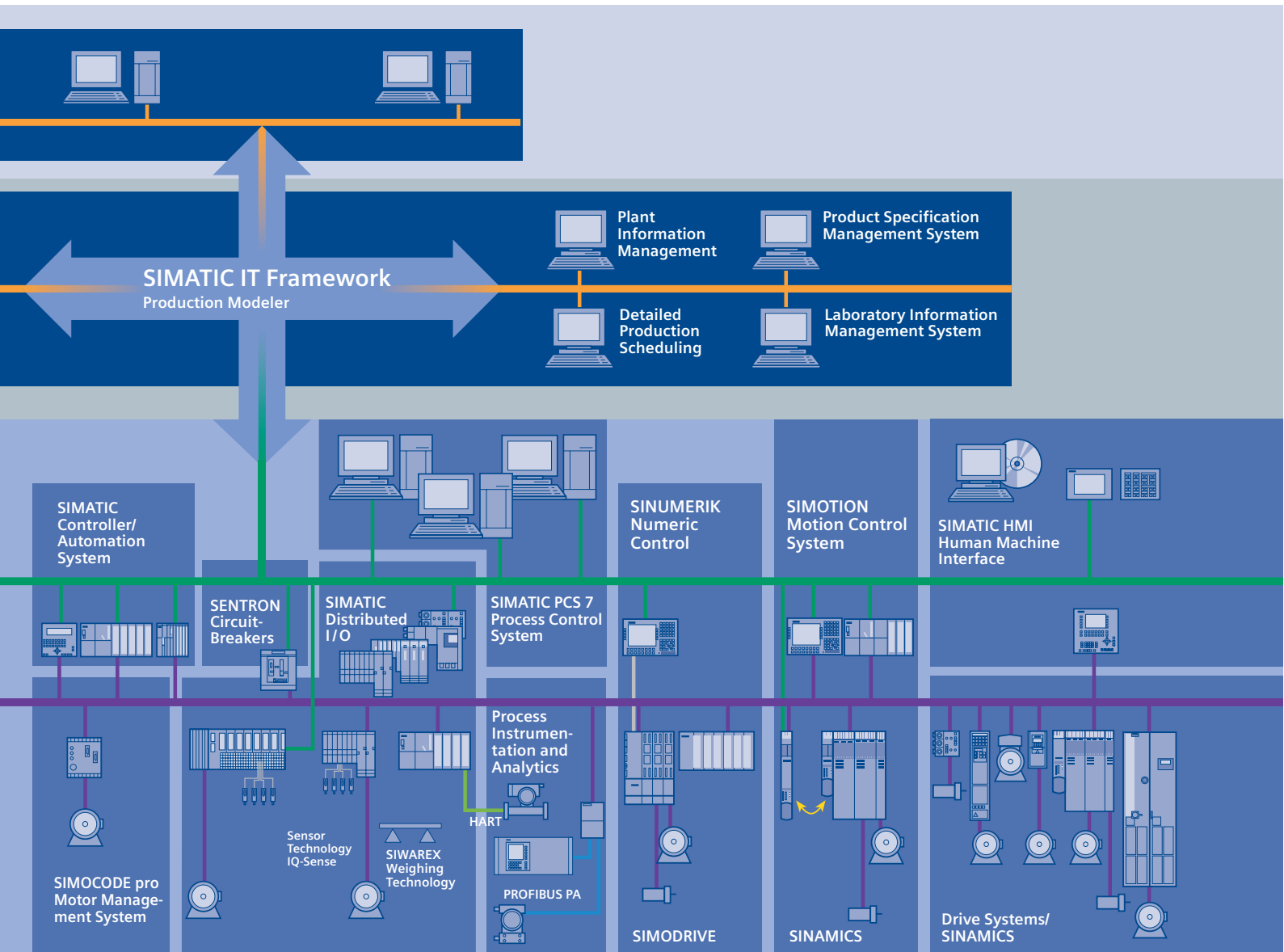

Selection guide

	MICROMASTER 410	MICROMASTER 420
Main characteristics	<p>“The low-priced” for variable speeds with three-phase motors on single-phase networks, e.g. with pumps, fans, billboards, barriers, gate drives and automatic machines</p>	<p>“The universal” for three-phase networks and optional fieldbus interfacing, e.g. for conveyor belts, material transport, pumps, fans and machine tools</p>
Power ranges	0.12 kW to 0.75 kW	0.12 kW to 11 kW
Voltage ranges	1 AC 100 V to 120 V 1 AC 200 V to 240 V	1 AC 200 V to 240 V 3 AC 200 V to 240 V 3 AC 380 V to 480 V
Control methods	<ul style="list-style-type: none"> • V/f characteristic • Multipoint characteristic (programmable V/f characteristic) • FCC (flux current control) 	<ul style="list-style-type: none"> • V/f characteristic • Multipoint characteristic (programmable V/f characteristic) • FCC (flux current control)
Process control	–	Internal PI controller
Inputs	3 digital inputs 1 analog input	3 digital inputs 1 analog input
Outputs	1 relay output	1 analog output 1 relay output
Interfacing to automation system	The PLC partner for LOGO! and SIMATIC S7-200	The ideal partner for your automation tasks, whether with SIMATIC S7-200, SIMATIC S7-300/400 (TIA) or SIMOTION
Additional features	<ul style="list-style-type: none"> • Natural ventilation (no fan unit) • Position of connections as with conventional switching elements (e.g. contactors) • Variant with flat plate heatsink 	<ul style="list-style-type: none"> • BICO technology • Compound braking for controlled rapid braking
		
	Section 1	Section 2

MICROMASTER 430

“The specialist for pumps and fans”
with optimized OP (manual/automatic switchover), matched software functionality and optimized power yield

7.5 kW to 250 kW

3 AC 380 V to 480 V

- V/f characteristic
- Multipoint characteristic (programmable V/f characteristic)
- FCC (flux current control)

Internal PID controller

6 digital inputs
2 analog inputs
1 PTC/KTY input

2 analog outputs
3 relay outputs

The ideal partner for your automation tasks, whether with SIMATIC S7-200, SIMATIC S7-300/400 (TIA) or SIMOTION

- Low-energy mode
- Load torque monitoring (detects dry run of pumps)
- Motor staging
- Bypass mode
- BICO technology



Section 3

MICROMASTER 440

“The all-purpose”
with advanced vector control (with and without encoder feedback) for versatile applications in sectors such as conveying systems, textiles, elevators, hoisting equipment and machine construction

0.12 kW to 250 kW

1 AC 200 V to 240 V
3 AC 200 V to 240 V
3 AC 380 V to 480 V
3 AC 500 V to 600 V

- V/f characteristic
- Multipoint characteristic (programmable V/f characteristic)
- FCC (flux current control)
- Vector control

Internal PID controller (autotuning)

6 digital inputs
2 analog inputs
1 PTC/KTY input

2 analog outputs
3 relay outputs

The ideal partner for your automation tasks, whether with SIMATIC S7-200, SIMATIC S7-300/400 (TIA) or SIMOTION

- 3 selectable drive data kits
- Integrated brake chopper (up to 75 kW)
- Torque control
- BICO technology



Section 4

Overview

Options

Various options are available for the MICROMASTER inverters:

- Filters
- Chokes
- Operator panels
- PROFIBUS module
- DeviceNet module
- CANopen module
- Pulse encoder evaluation module
- Gland plates
- Mounting kits, etc.

Assignment of operator panels and modules to the inverter ranges

Options	Order No.	MICROMASTER			
		410	420	430	440
Operator panels					
OP	6SE6400-0SP00-0AA0	●			
BOP	6SE6400-0BP00-0AA0		●		●
BOP-2	6SE6400-0BE00-0AA0			●	
AOP	6SE6400-0AP00-0AA1		●		●
AAOP	6SE6400-0AP00-0AB0		●		●
Modules					
PROFIBUS	6SE6400-1PB00-0AA0		●	●	●
DeviceNet	6SE6400-1DN00-0AA0		●	●	●
CANopen	6SE6400-1CB00-0AA0		●	●	●
Pulse encoder evaluation	6SE6400-0EN00-0AA0			●	●

● Possible combination



OP/BOP

BOP-2

AOP

AAOP

Operator panels



PROFIBUS

DeviceNet

CANopen

Pulse encoder evaluation

Modules

Inverter

MICROMASTER 410



1/2	Description
1/4	Circuit diagrams
1/6	Technical data
1/7	Selection and ordering data
1/8	Options
1/10	Dimension drawings

1



Description



Inverter
Frame size AA



Inverter
Frame size AB



Inverter
with flat heat sink

Application

The MICROMASTER 410 inverter is suitable for a variety of variable-speed drive applications.

It is especially suitable for use with pumps and fans, as a drive in various sectors, e.g. food, textile and packaging industries as well as for conveyor systems, factory gate and garage door drives and as a universal drive for moving billboards.

It is the ideal low-cost frequency inverter solution for the low-end performance range of the MICROMASTER product family.

The inverter is especially characterized by its customer-oriented performance and ease-of-use.

Versions for connecting to 230 V and 115 V single-phase networks enable it to be used all over the world.

Design

The MICROMASTER 410 inverter has a compact design.

Heatsinks provide natural cooling for the inverter. A fan unit is not used.

The position of the connections has been selected as for conventional contactors.

The operator panel available as an option can be easily fitted without requiring any tools.

The design with flat plate heat-sink offers space-saving and favorable heat dissipation since an additional heatsink can be installed outside the control cabinet.

Main characteristics

- Simple selection from minimum range of types (only a few options)
- Compact design
- Natural cooling with heat sinks (no fan unit)
- Simple connection similar to conventional switching elements (e.g. contactors)
- Versions with internal EMC filter Class B
- Fast, simple commissioning with input of only a few parameters (fast commissioning mode)
- Integrated RS-485 communications interface
- Three programmable digital inputs, non-floating (the analog input can be used as a fourth binary input)
- One analog input (0 V to 10 V)
- One programmable relay output (30 V DC/5 A resistive load; 250 V AC/2A inductive load)
- Low-noise motor operation resulting from high pulse frequency
- Integrated protection for motor and inverter.

Options (overview)

- Line commutating chokes
- Adapter for standardized mounting on DIN rails
- OP (Operator Panel) for user-friendly parameterization of an inverter
- Connection kit for PC to inverter
- PC startup program.

International standards

- The MICROMASTER 410 inverter complies with the requirements of the EU low-voltage guideline
- The MICROMASTER 410 inverter has the **CE** marking
- ® and c® listed (not for versions with flat heat sinks)
- c-tick **C**

Note:

See Appendix for standards.

Mechanical features

- Compact design
- Heat dissipation through self-ventilation (convection)
- Operating temperature -10 °C to +50 °C (+14 °F to +122 °F)
- Easy cable connection, mains and motor connections are separated for optimal electromagnetic compatibility and clear connection
- Detachable, optional operator panels
- Screwless control terminals
- Side mounting possible, thus also usable with low cabinet depth.

Performance features

- Latest IGBT technology
- Digital microprocessor control
- Linear V/f characteristic, with programmable voltage boosting
- Quadratic V/f characteristic
- Multipoint characteristic (programmable V/f characteristic)
- Flying restart
- Automatic restart after mains failure or fault
- Programmable ramp generator (0 s to 650 s) with possible rounding
- Fast current limit (FCL) for trip-free operation

Protection features

- Fast, repeatable digital input response time
- Exact setpoint specification using a high-resolution 10-bit analog input
- One skip frequency range
- Removable Y cap for use in IT systems
- Serial RS-485 interface with USS protocol
- LED for status information
- Versions with internal EMC filter Class B
- Overload current 1.5 x rated output current (i.e. 150 % overload capability) for 60 s, then 0.85 x rated output current for 240 s, cycle time 300 s
- Overvoltage/undervoltage protection
- Inverter overtemperature protection
- Earth fault protection
- Short-circuit protection
- I^2t motor thermal protection
- Stall prevention.

Circuit diagrams

General circuit diagram

1

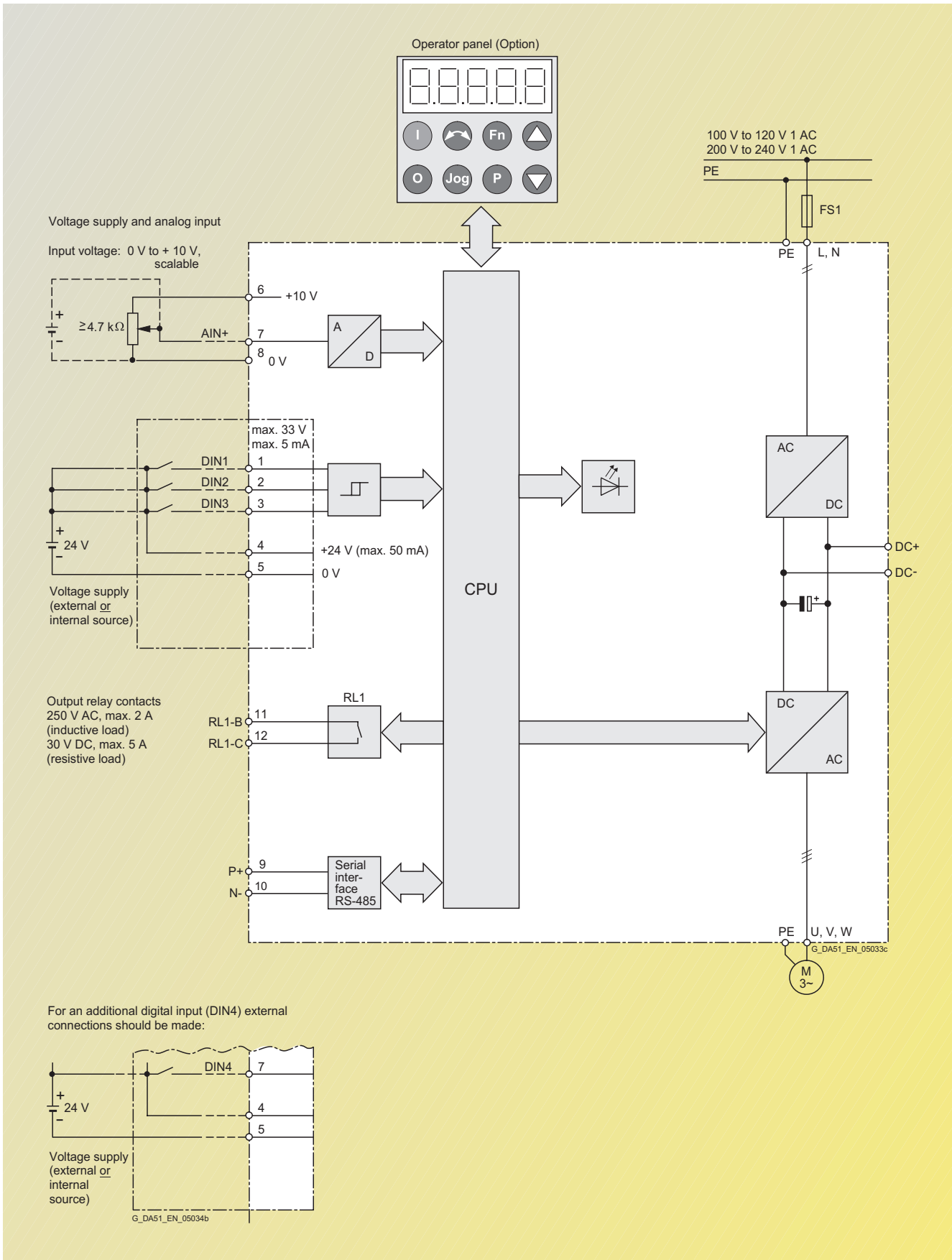

Terminal connection diagram

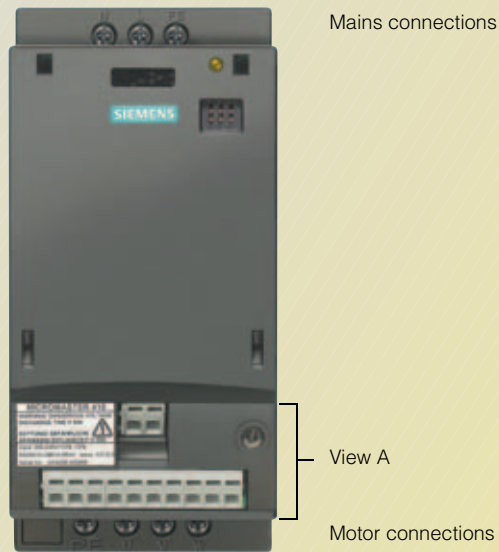

View A

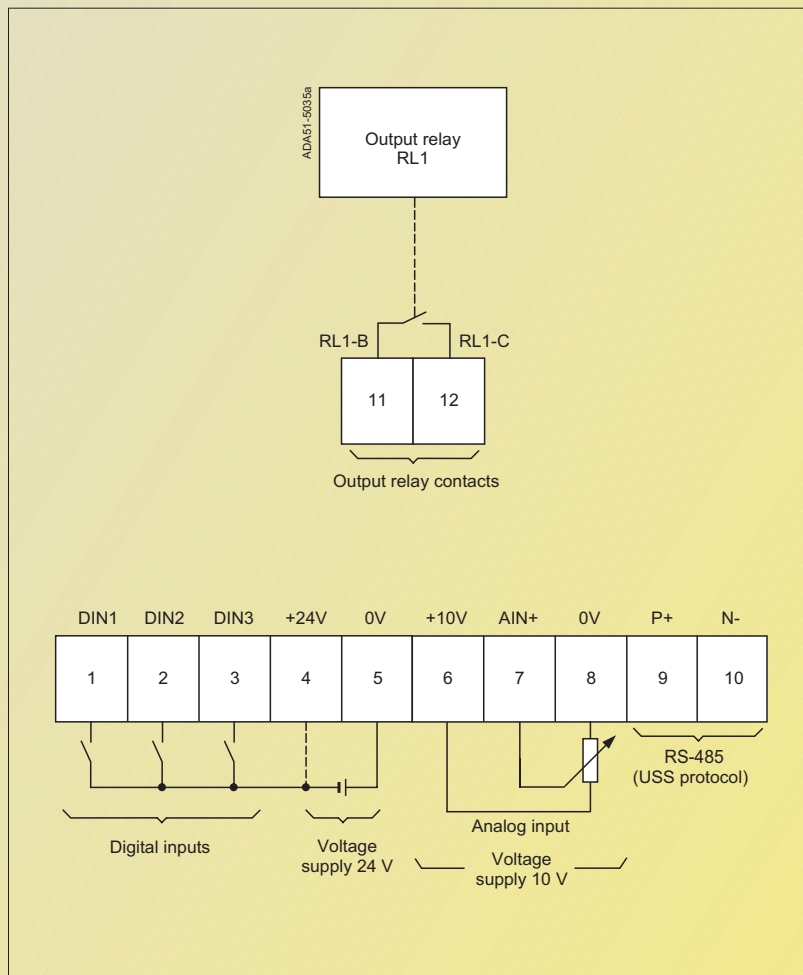

MICROMASTER 410

Technical data

MICROMASTER 410 inverter

Input voltages and power ranges	1 AC 200 V to 240 V \pm 10 % 1 AC 100 V to 120 V \pm 10 %	0.12 to 0.75 kW 0.12 to 0.55 kW
Power frequency	47 to 63 Hz	
Output frequency	0 Hz to 650 Hz	
Power factor	\geq 0.95	
Inverter efficiency	90 % to 95 %	
Overload capability	Overload current 1.5 x rated output current (i.e. 150 % overload capability) for 60 s; then 0.85 x rated output current for 240 s, cycle time 300 s	
Precharge current	Not higher than rated input current	
Control method	Linear V/f characteristic; quadratic V/f characteristic; multipoint characteristic (programmable V/f characteristic)	
Pulse frequency	8 kHz (standard)/2 kHz to 16 kHz (in 2 kHz steps)	
Fixed frequencies	3, programmable	
Skip frequency ranges	1, programmable	
Setpoint resolution	10 bit analog/0.01 Hz serial	
Digital inputs	3 programmable digital inputs, non-floating, PNP, SIMATIC-compatible	
Analog input	1, for setpoint (0 V to 10 V, scaleable or for use as 4th digital input)	
Relay outputs	1, programmable, 30 V DC/5 A (resistive load); 250 V AC/2A (inductive load)	
Serial interface	RS-485, for operation with USS protocol	
Motor cable lengths	Max. 30 m (shielded)/max. 50 m (unshielded)	
Electromagnetic compatibility	Inverter available with internal EMC filter to EN 61 800-3 (defined limits to EN 55 011, Class B)	
Braking	DC braking, compound braking	
Degree of protection	IP20	
Operating temperature	-10 °C to +50 °C (+14 °F to +122 °F)	
Storage temperature	-40 °C to +70 °C (-40 °F to +158 °F)	
Relative humidity	95 % (non-condensing)	
Site altitude	Up to 1000 m above sea level without derating	
Protection features for	Undervoltage, overvoltage, overload, earth faults, short circuits, stall prevention, I^2t motor thermal protection, inverter overtemperature	
Typical power losses (heatsink) at full load and maximum operating temperature as specified	20 W (with 0.37 kW inverter with flat plate heatsink) 37 W (with 0.75 kW inverter with flat plate heatsink)	
Line-side and control electronics losses (at 230 V, 50 Hz, 8 kHz)	18 W (with 0.37 kW inverter with flat plate heatsink) 34 W (with 0.75 kW inverter with flat plate heatsink)	
Recommended thermal resistance of heatsink	1.8 K/W (with 0.37 kW inverter with flat plate heatsink) 1.2 K/W (with 0.75 kW inverter with flat plate heatsink)	
Compliance with standards	Ⓜ, cⓂ (not for versions with flat plate heatsink) CE, c-tick	
CE marking	Conformity with low-voltage directive 73/23/EC	
Dimensions and weights (without options)	Frame size (FS)	H x W x D (mm) Weight, approx. (kg)
	AA	150 x 69 x 118 0.8
	AB	150 x 69 x 138 1.0
	0.37 kW inverter with flat plate heatsink	175 x 69 x 102 0.78
	0.75 kW inverter with flat plate heatsink	175 x 69 x 102 0.8

Derating data

Pulse frequency

Output kW	Rated output current in A for a pulse frequency of						
	4 kHz	6 kHz	8 kHz	10 kHz	12 kHz	14 kHz	16 kHz
0.12	0.9	0.9	0.9	0.8	0.7	0.6	0.5
0.25	1.7	1.7	1.7	1.5	1.3	1.1	0.9
0.37	2.3	2.3	2.3	2.0	1.7	1.5	1.3
0.55	3.2	3.2	3.2	2.9	2.6	2.3	2.0
0.55, 115 V (at 50 °C/122 °F)	3.0	3.0	2.7	2.5	2.2	2.0	1.7
0.55, 115 V (at 40 °C/104 °F)	3.2	3.2	3.2	2.9	2.6	2.3	2.0
0.75 (at 50 °C/122 °F)	3.9	3.9	3.6	3.2	2.9	2.6	2.3
0.75 (at 40 °C/104 °F)	4.2	4.2	4.2	3.8	3.4	3.0	2.7

The current data apply to an ambient temperature of 50 °C/122 °F unless specified otherwise.

Derating data (continued)

Installation height above sea level

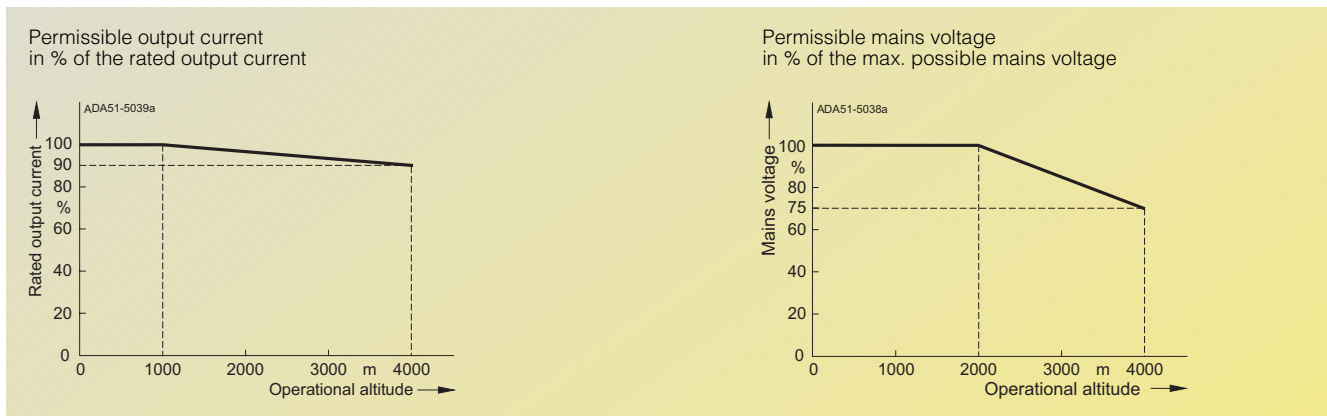

Selection and ordering data

MICROMASTER 410 inverter

Output		Rated input current ¹⁾		Rated output current	Frame size	Order No.	
kW	hp	A	A	A	(FS)	MICROMASTER 410 without filter ²⁾	MICROMASTER 410 with internal filter Class B
Mains voltage 1 AC 100 V to 120 V, output voltage 200 V to 240 V 3-phase							
0.12	0.16	4.6	0.9	AA		6SE6410-2UA11-2AA0	–
0.25	0.33	7.5	1.7	AA		6SE6410-2UA12-5AA0	–
0.37	0.50	10.1	2.3	AA		6SE6410-2UA13-7AA0	–
0.55	0.75	13.4	2.7 (3.2 at 40 °C/104 °F)	AB		6SE6410-2UA15-5BA0	–
Mains voltage 1 AC 200 V to 240 V, output voltage 200 V to 240 V 3-phase							
0.12	0.16	1.5	0.9	AA		6SE6410-2UB11-2AA0	6SE6410-2BB11-2AA0
0.25	0.33	3.0	1.7	AA		6SE6410-2UB12-5AA0	6SE6410-2BB12-5AA0
0.37	0.50	4.4	2.3	AA		6SE6410-2UB13-7AA0	6SE6410-2BB13-7AA0
0.55	0.75	5.8	3.2	AB		6SE6410-2UB15-5BA0	6SE6410-2BB15-5BA0
0.75	1.0	7.8	3.6 (4.2 at 40 °C/104 °F)	AB		6SE6410-2UB17-5BA0	6SE6410-2BB17-5BA0
Inverter with flat plate heatsink							
0.37	0.5	4.4	2.3	AA		6SE6410-2UB13-7AB0	6SE6410-2BB13-7AB0
0.75	1	7.8	4.2 (at 40 °C/104 °F)	AB		6SE6410-2UB17-5BB0	6SE6410-2BB17-5BB0

The current data apply to an ambient temperature of 50 °C/122 °F unless specified otherwise.

- 1) The values apply to rated mains voltages of 115 V or 230 V.
- 2) Generally suited to heavy industrial applications. For details please refer to Appendix on page A/4.



See Appendix for note on ordering.

All MICROMASTER 410 inverters are supplied without an Operator Panel (OP). An OP or other options must be ordered separately (see Page 1/9).

Motors for MICROMASTER 410

Catalog M 11 contains selection and ordering data for motors which are particularly suitable for operation with the MICROMASTER 410 inverters (see Appendix for overview). This catalog is suitable for IEC motors. For motors according to US standards (NEMA) please refer to: <http://www.sea.siemens.com/motors>

Options Inverter dependent options

Overview

EMC filter, Class B

Variants with **internal** EMC filter Class B are available for inverters with a mains operating voltage of 1 230 V AC.

- The requirements are satisfied using: shielded cables with a max. length of 5 m, or 10 m with a low-capacitance motor cable (core/core < 75 pF/m, core/shield < 150 pF/m). The limits comply with EN 55 011 Class B.

An inverter with internal filter can be used with a 30 mA residual current operated circuit-breaker, and is only suitable for hardwired installation.

A non-filtered inverter together with the optional filter "Filter Class B with low leakage currents" has a leakage current ≤ 3.5 mA (shielded motor cable up to 5 m).

Line commutating choke

Line commutating chokes are used to smooth voltage peaks or to bridge commutating dips.

In addition, line commutating chokes reduce the effects of harmonics on the inverter and the power supply.

If the ratio of inverter rated power to mains short-circuit

power is less than 1 %, a line commutating choke must be used in order to reduce the current peaks.

The line commutating chokes are designed as footprint chokes and are fitted between the inverter and the mounting plate.

In line with EN 61 000-3-2 regulations "Limits for harmonic currents with device input current ≤ 16 A per phase", there are special aspects for drives with 250 W to 550 W and 230 V single-phase supplies which can be used in non-industrial applications (1st environment).

For devices with 250 W and 370 W, it is necessary either to fit the recommended input chokes or to apply to the power utility company for authorization to connect the devices to the public power supply. No limits are currently defined in the EN 61 000-3-2 standard for professionally used devices with a connected load > 1 kW, which means that the inverters with an output power ≥ 0.75 kW comply with the EN 61 000-3-2 standard.

Selection and ordering data

The options listed here (filters, chokes, fuses and circuit-breakers) must be selected to match the inverter.

The inverter and the associated options have the same voltage ratings.

All variant dependent options and the operator panel are certified to $\text{\textcircled{R}}$ except fuses. Fuses of Type 3NA3 are recommended for Europe.

Use in America requires $\text{\textcircled{R}}$ -listed fuses such as the Class NON range from Bussmann.

Mains voltage	Output		Inverter without filter	Order No. of the options				
	kW	hp		Filter Class B with low leakage currents	Line commutating choke	Fuse (see Catalog LV 10)	Circuit-breaker (see Catalog LV 10)	
1 AC 100 V to 120 V	0.12	0.16	6SE6410-2UA11-2AA0	–	6SE6400-3CC01-0AB3	3NA3803	3RV1021-1GA10	
	0.25	0.33	6SE6410-2UA12-5AA0	–			3RV1021-1JA10	
	0.37	0.50	6SE6410-2UA13-7AA0 *)	–	6SE6400-3CC02-6BB3	3NA3805	3RV1021-1KA10	
	0.55	0.75	6SE6410-2UA15-5BA0 *)	–		3NA3807	3RV1021-4AA10	
1 AC 200 V to 240 V	0.12	0.16	6SE6410-2UB11-2AA0	6SE6400-2FL01-0AB0	6SE6400-3CC00-4AB3	3NA3803	3RV1021-1BA10	
	0.25	0.33	6SE6410-2UB12-5AA0				3RV1021-1EA10	
	0.37	0.50	6SE6410-2UB13-7AA0		6SE6400-3CC01-0AB3		3RV1021-1FA10	
	0.55	0.75	6SE6410-2UB15-5BA0				3RV1021-1HA10	
	0.75	1.0	6SE6410-2UB17-5BA0			3NA3805	3RV1021-1JA10	
			Inverter with flat plate heatsink					
	0.37	0.50	6SE6410-2UB13-7AB0 *)	6SE6400-2FL01-0AB0	6SE6400-3CC01-0AB3	3NA3803	3RV1021-1FA10	
	0.75	1.0	6SE6410-2UB17-5BB0 *)			3NA3805	3RV1021-1JA10	
			Inverter with internal filter Class B					
1 AC 200 V to 240 V	0.12	0.16	6SE6410-2BB11-2AA0	–	6SE6400-3CC00-4AB3	3NA3803	3RV1021-1BA10	
	0.25	0.33	6SE6410-2BB12-5AA0	–			3RV1021-1EA10	
	0.37	0.50	6SE6410-2BB13-7AA0	–	6SE6400-3CC01-0AB3		3RV1021-1FA10	
	0.55	0.75	6SE6410-2BB15-5BA0	–			3RV1021-1HA10	
	0.75	1.0	6SE6410-2BB17-5BA0	–		3NA3805	3RV1021-1JA10	
			Inverter with flat plate heatsink					
	0.37	0.50	6SE6410-2BB13-7AB0 *)	–	6SE6400-3CC01-0AB3	3NA3803	3RV1021-1FA10	
	0.75	1.0	6SE6410-2BB17-5BB0 *)	–		3NA3805	3RV1021-1JA10	

*) With these inverters, the filter or choke cannot be mounted in the substructure. This option must be mounted upright.

Overview

Operator Panel (OP)

With the OP, individual parameter settings can be made.

Values and units are shown on a 5-digit display.

An OP can be used for several inverters. It is directly plugged into the inverter.



Inverter with Operator Panel (OP)

Connection kit for PC to inverter

For controlling and commissioning an inverter directly from a PC if the appropriate software has been installed (e.g. STARTER).

The connection kit includes an RS-485/RS-232 interface converter with a 9-pin Sub-D connector.

Start-up tools

- **STARTER** is a graphic start-up software for guided start-up for MICROMASTER 410/420/430/440 frequency inverters under Windows NT/2000/XP Professional. Parameter lists can be read out, altered, stored, entered and printed.
- **DriveMonitor** is a start-up software for list-oriented programming of frequency inverters. This program executes under Windows 98/NT/2000/ME/XP Professional.

Selection and ordering data

The options listed here are suitable for all MICROMASTER 410 inverters.

Options	Order No.
Operator Panel (OP)	6SE6400-0SP00-0AA0
Connection kit for PC to inverter	6SE6400-0PL00-0AA0
Adapter for mounting on DIN rails	6SE6400-0DR00-0AA0
Start-up tools STARTER and DriveMonitor ²⁾ , as well as multilanguage documentation on CD-ROM	6SE6400-5EA00-1AG0
Start-up tool STARTER on CD-ROM ²⁾	6SL3072-0AA00-0AG0

Documentation

Selection and ordering data

Type of documentation	Language	Order No.
Operating instructions¹⁾ (paper version)	German	6SE6400-5EA00-0AP0
	English	6SE6400-5EA00-0BP0
	French	6SE6400-5EA00-0DP0
	Italian	6SE6400-5EA00-0CP0
	Spanish	6SE6400-5EA00-0EP0
Parameter list¹⁾ (paper version)	German	6SE6400-5EB00-0AP0
	English	6SE6400-5EB00-0BP0
	French	6SE6400-5EB00-0DP0
	Italian	6SE6400-5EB00-0CP0
	Spanish	6SE6400-5EB00-0EP0
Getting Started Guide¹⁾ (paper version), included with every inverter	Multilanguage	–

1) Available on the Internet at <http://www.siemens.com/micromaster>

2) Available on the Internet: DriveMonitor at <http://www4.ad.siemens.de/WW/view/com/10804984/133100>

STARTER at <http://www4.ad.siemens.de/WW/view/com/10804985/133100>

MICROMASTER 410

Dimension drawings

1

MICROMASTER 410 inverter

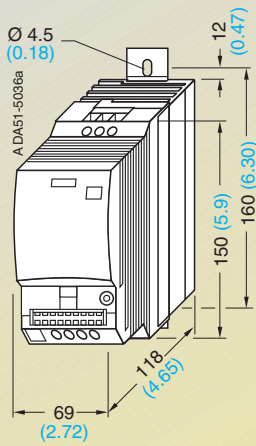

Inverter frame size AA
 6SE6410-2 . . . 11-2AA0
 6SE6410-2 . . . 12-5AA0
 6SE6410-2 . . . 13-7AA0

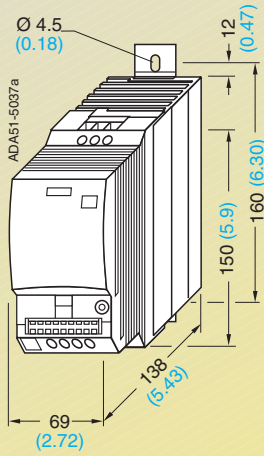

Inverter frame size AB
 6SE6410-2 . . . 15-5BA0
 6SE6410-2 . . . 17-5BA0

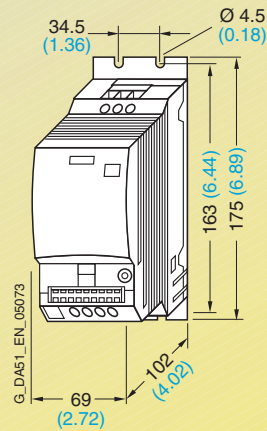

Inverter with flat plate heatsink
 6SE6410-2 . B13-7AB0
 6SE6410-2 . B17-5BB0

All dimensions in mm (values in brackets are in inches)

Filters and chokes

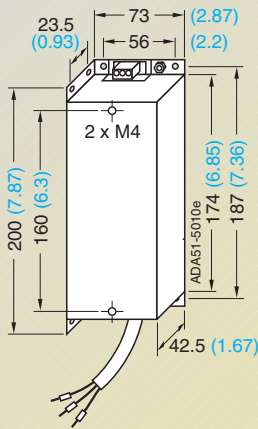

Filter
 6SE6400-2FL01-0AB0

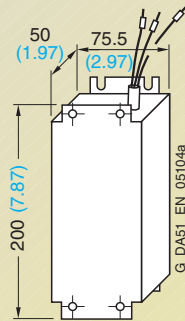

Footprint chokes
 6SE6400-3CC00-4AB3
 6SE6400-3CC01-0AB3

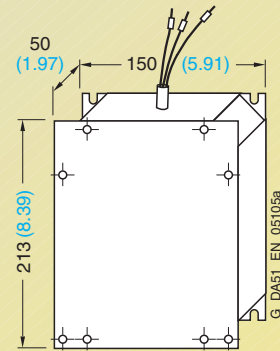

Choke for upright mounting
 6SE6400-3CC02-6BB3

All dimensions in mm (values in brackets are in inches)

Inverter

MICROMASTER 420



2/2

Description

2/4

Circuit diagrams

2/6

Technical data

2/8

Selection and ordering data

2/9

Options

2/18

Dimension drawings

2



Description



2

Applications

The MICROMASTER 420 inverter is suitable for a variety of variable-speed drive applications. It is especially suitable for applications with pumps, fans and in conveyor systems.

It is the ideal cost-optimized frequency inverter solution. The inverter is especially characterized by its customer-oriented performance and ease-of-use. Its large mains voltage range enables it to be used all over the world.

Design

The MICROMASTER 420 inverter has a modular design. The operator panels and communication modules can be easily exchanged without requiring any tools.

Main characteristics

- Easy, guided start-up
- Modular construction allows maximum configuration flexibility
- Three fully programmable isolated digital inputs
- One analog input (0 V to 10 V, scaleable) or for use as 4th digital input
- One programmable analog output (0 mA to 20 mA)
- One programmable relay output (30 V DC/5 A resistive load; 250 V AC/2A inductive load)
- Low-noise motor operation through high pulse frequency, adjustable (observe derating if necessary)
- Complete protection for motor and inverter.

Options (overview)

- EMC filter, Class A/B
- LC filter
- Line commutating chokes
- Output chokes
- Gland plates
- Basic Operator Panel (BOP) for parameterizing the inverter
- Advanced Operator Panel (AOP) with multi-language plain text display
- Asian Advanced Operator Panel (AAOP) with Chinese and English plain text display
- Communication modules
 - PROFIBUS
 - DeviceNet
 - CANopen
- PC connection kits
- Mounting kits for installing the operator panels in the control cabinet doors
- PC start-up programs executable under Windows 98 and NT/2000/ME/XP Professional
- TIA integration with Drive ES

International standards

- The MICROMASTER 420 inverter complies with the requirements of the EU low-voltage guideline
- The MICROMASTER 420 inverter has the **CE** marking
- acc. to **UL** and **cUL** certified
- c-tick **C**

Note:

See Appendix for standards.

Mechanical features

- Modular design
- Operating temperature
–10 °C to +50 °C
(+14 °F to +122 °F)
- Compact housing as a result of high power density
- Easy cable connection, mains and motor connections are separated for optimum electromagnetic compatibility
- Detachable operator panels
- Screwless control terminals

Performance features

- Latest IGBT technology
- Digital microprocessor control
- Flux Current Control (FCC) for improved dynamic response and optimized motor control
- Linear V/f characteristic
- Quadratic V/f characteristic
- Multipoint characteristic (programmable V/f characteristic)
- Flying restart
- Slip compensation
- Automatic restart following mains failure or fault
- Internal PI controller for simple process control

Protection features

- Programmable acceleration/deceleration times from 0 s to 650 s
- Ramp smoothing
- Fast Current Limit (FCL) for trip-free operation
- Fast, repeatable digital input response time
- Fine adjustment using a high-resolution 10-bit analog input
- Compound braking for controlled rapid braking
- Four skip frequencies
- Removable “Y” capacitor for use on IT systems (with non-grounded mains supplies, the “Y” capacitor must be removed and an output choke installed).
- Overload current 1.5 x rated output current (i.e. 150 % overload capability) for 60 s, cycle time 300 s
- Overvoltage/undervoltage protection
- Inverter overtemperature protection
- Motor protection using PTC via digital input (possible with supplementary circuit)
- Earth fault protection
- Short-circuit protection
- βt motor thermal protection
- Locked motor protection
- Stall prevention
- Parameter interlock

Circuit diagrams

General circuit diagram

2

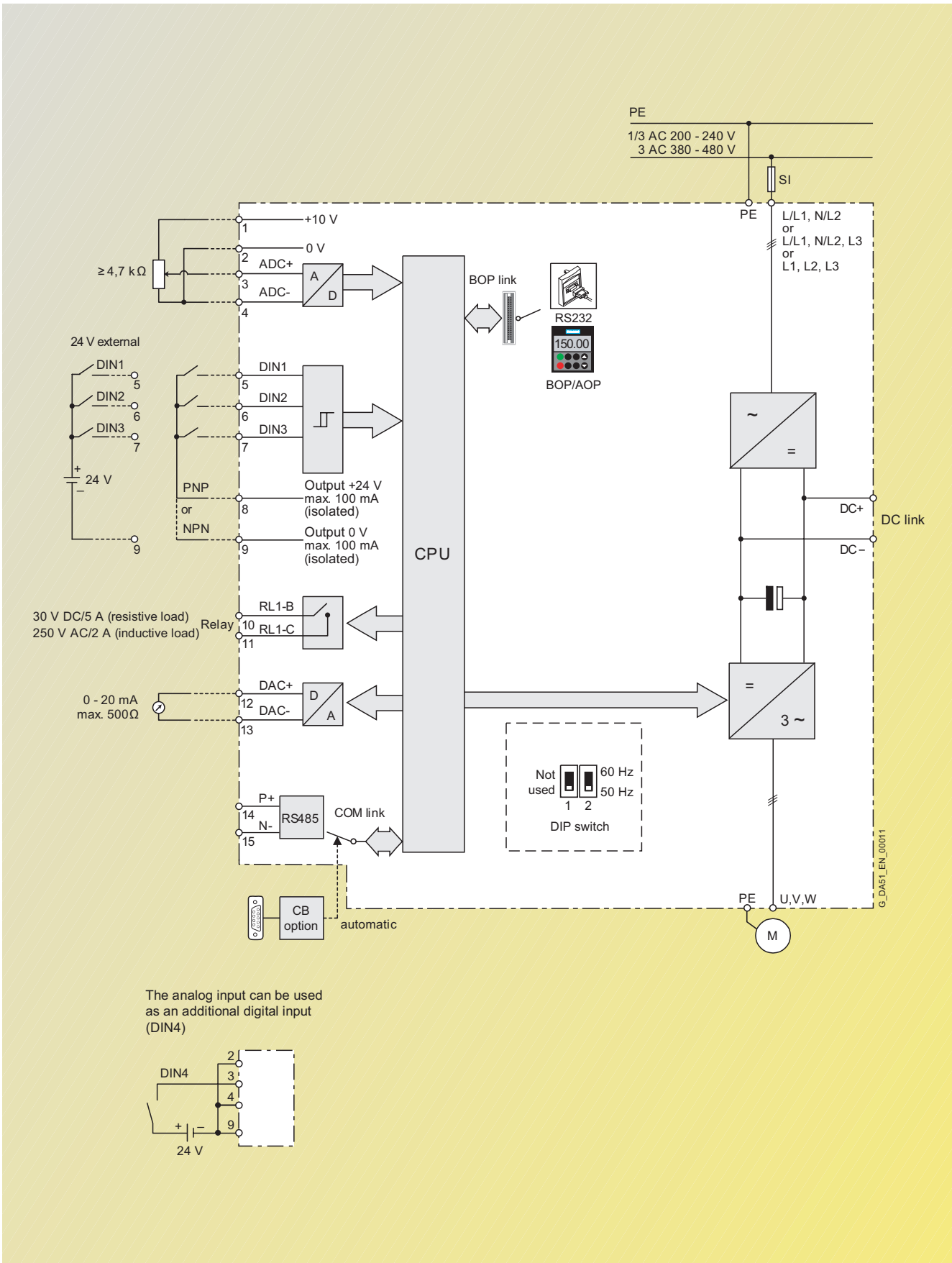

Terminal connection diagram

Example frame size A

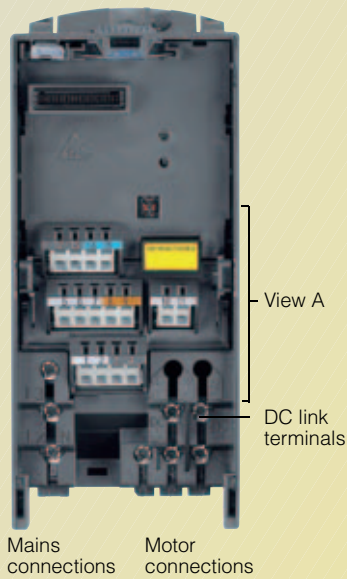

View A

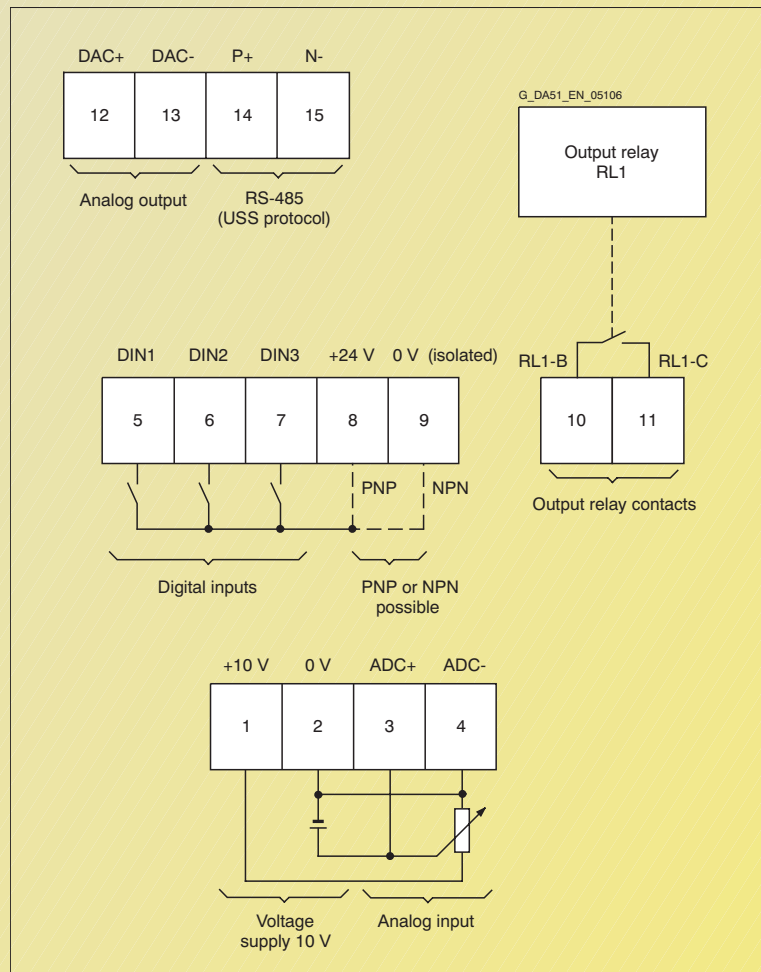

MICROMASTER 420

Technical data

MICROMASTER 420 inverter

Mains voltage and power ranges	1 AC 200 V to 240 V ± 10 % 3 AC 200 V to 240 V ± 10 % 3 AC 380 V to 480 V ± 10 %	0.12 kW to 3 kW 0.12 kW to 5.5 kW 0.37 kW to 11 kW		
Power frequency	47 Hz to 63 Hz			
Output frequency	0 Hz to 650 Hz			
Power factor	≥ 0.95			
Inverter efficiency	96 % to 97 %			
Overload capability	Overload current 1.5 x rated output current (i.e. 150 % overload capability) for 60 s, cycle time 300 s			
Inrush current	Less than rated input current			
Control method	Linear V/f-characteristic; quadratic V/f characteristic; multipoint characteristic (programmable V/f characteristic); flux current control (FCC)			
Pulse frequency	16 kHz (standard with 1/3 AC 230 V) 4 kHz (standard with 3 AC 400 V) 2 kHz to 16 kHz (in 2 kHz steps)			
Fixed frequencies	7, programmable			
Skip frequency ranges	4, programmable			
Setpoint resolution	0.01 Hz digital 0.01 Hz serial 10 bit analog			
Digital inputs	3 fully programmable isolated digital inputs; switchable PNP/NPN			
Analog input	1, for setpoint or PI controller (0 V to 10 V, scaleable or for use as 4th digital input)			
Relay outputs	1, programmable, 30 V DC/5 A (resistive load); 250 V AC/2A (inductive load)			
Analog output	1, programmable (0 mA to 20 mA)			
Serial interfaces	RS-485, optional RS-232			
Motor cable lengths	without output choke	max. 50 m (shielded) max. 100 m (unshielded)		
	without output choke	see variant dependent options		
Electromagnetic compatibility	Inverter available with internal EMC filter Class A; available as options are EMC filters to EN 55 011, Class A or Class B			
Braking	DC braking, compound braking			
Degree of protection	IP20			
Operating temperature	-10 °C to +50 °C (+14 °F to +122 °F)			
Storage temperature	-40 °C to +70 °C (-40 °F to +158 °F)			
Relative humidity	95 % (non-condensing)			
Site altitude	Up to 1000 m above sea level without derating			
Protection features for	<ul style="list-style-type: none"> • Undervoltage • Overvoltage • Overload • Earth faults • Short circuit • Stall prevention • Locked motor protection • Motor overtemperature • Inverter overtemperature • Parameter interlock 			
Compliance with standards	Ⓜ, cⓂ, CE, c-tick			
CE marking	Conformity with low-voltage directive 73/23/EEC			
Cooling-air volumetric flow required, dimensions and weights (without options)	Frame size (FS)	Cooling-air volumetric flow required (l/s)/(CFM)	H x W x D (mm)	Weight, approx. (kg)
	A	4.8/10.2	173 x 73 x 149	1.0
	B	24/51	202 x 149 x 172	3.3
	C	54.9/116.3	245 x 185 x 195	5.0

CFM: Cubic Flow per Minute

Derating data

PWM frequency

Output (for 3 AC 400 V) kW	Rated output current in A for a pulse frequency of						
	4 kHz	6 kHz	8 kHz	10 kHz	12 kHz	14 kHz	16 kHz
0.37	1.2	1.2	1.2	1.2	1.2	1.2	1.1
0.55	1.6	1.6	1.6	1.6	1.6	1.6	1.1
0.75	2.1	2.1	2.1	2.1	1.6	1.6	1.1
1.1	3.0	3.0	2.7	2.7	1.6	1.6	1.1
1.5	4.0	4.0	2.7	2.7	1.6	1.6	1.1
2.2	5.9	5.9	5.1	5.1	3.6	3.6	2.6
3.0	7.7	7.7	5.1	5.1	3.6	3.6	2.6
4.0	10.2	10.2	6.7	6.7	4.8	4.8	3.6
5.5	13.2	13.2	13.2	13.2	9.6	9.6	7.5
7.5	19.0	18.4	13.2	13.2	9.6	9.6	7.5
11	26.0	26.0	17.9	17.9	13.5	13.5	10.4

Operating temperature

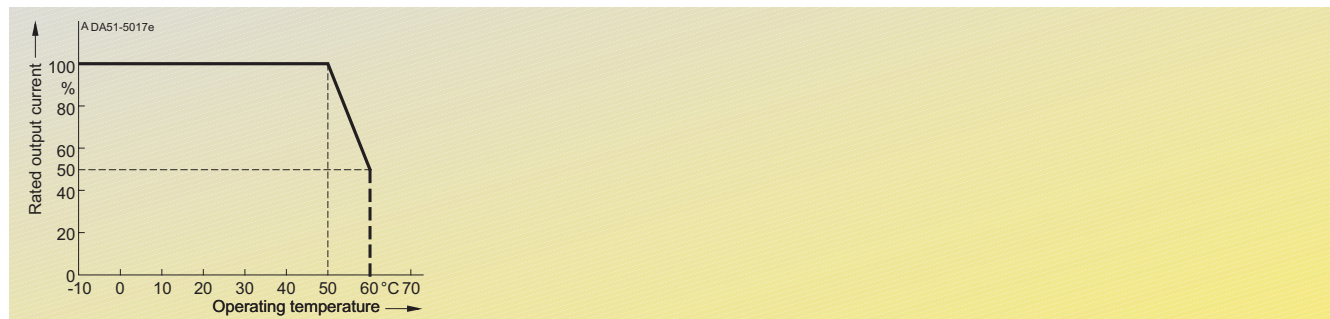

Installation height above sea level

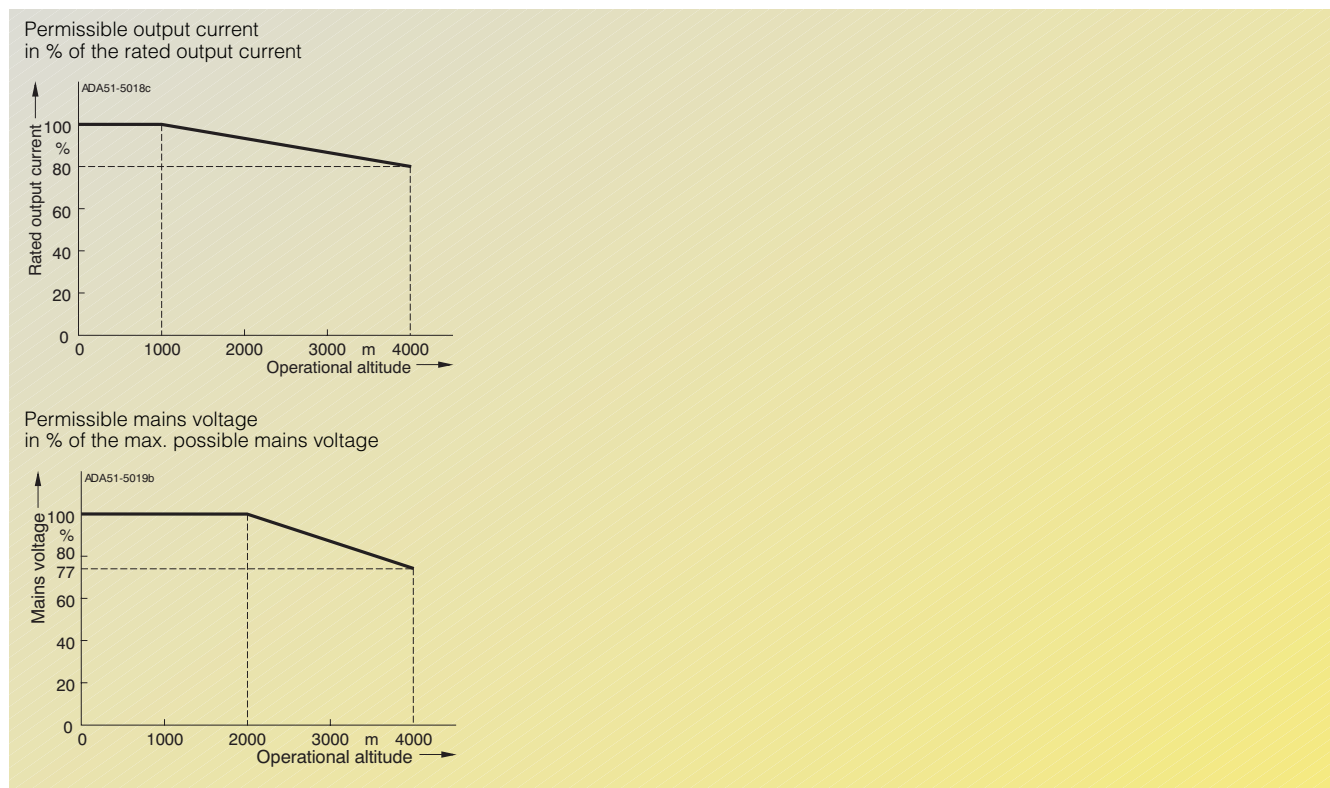

Selection and ordering data

MICROMASTER 420 inverter

Output		Rated input current ¹⁾	Rated output current	Frame size	Order No.	
kW	hp	A	A	(FS)	MICROMASTER 420 without filter ³⁾	MICROMASTER 420 with internal filter Class A ²⁾
Mains operating voltage 1 AC 200 V to 240 V						
0.12	0.16	1.8	0.9	A	6SE6420-2UC11-2AA1	6SE6420-2AB11-2AA1
0.25	0.33	3.2	1.7	A	6SE6420-2UC12-5AA1	6SE6420-2AB12-5AA1
0.37	0.50	4.6	2.3	A	6SE6420-2UC13-7AA1	6SE6420-2AB13-7AA1
0.55	0.75	6.2	3.0	A	6SE6420-2UC15-5AA1	6SE6420-2AB15-5AA1
0.75	1.0	8.2	3.9	A	6SE6420-2UC17-5AA1	6SE6420-2AB17-5AA1
1.1	1.5	11.0	5.5	B	6SE6420-2UC21-1BA1	6SE6420-2AB21-1BA1
1.5	2.0	14.4	7.4	B	6SE6420-2UC21-5BA1	6SE6420-2AB21-5BA1
2.2	3.0	20.2	10.4	B	6SE6420-2UC22-2BA1	6SE6420-2AB22-2BA1
3.0	4.0	35.5	13.6	C	6SE6420-2UC23-0CA1	6SE6420-2AB23-0CA1
Mains operating voltage 3 AC 200 V to 240 V						
0.12	0.16	1.1	0.9	A	6SE6420-2UC11-2AA1	–
0.25	0.33	1.9	1.7	A	6SE6420-2UC12-5AA1	–
0.37	0.50	2.7	2.3	A	6SE6420-2UC13-7AA1	–
0.55	0.75	3.6	3.0	A	6SE6420-2UC15-5AA1	–
0.75	1.0	4.7	3.9	A	6SE6420-2UC17-5AA1	–
1.1	1.5	6.4	5.5	B	6SE6420-2UC21-1BA1	–
1.5	2.0	8.3	7.4	B	6SE6420-2UC21-5BA1	–
2.2	3.0	11.7	10.4	B	6SE6420-2UC22-2BA1	–
3.0	4.0	15.6	13.6	C	6SE6420-2UC23-0CA1	6SE6420-2AC23-0CA1
4.0	5.0	19.7	17.5	C	6SE6420-2UC24-0CA1	6SE6420-2AC24-0CA1
5.5	7.5	26.5	22.0	C	6SE6420-2UC25-5CA1	6SE6420-2AC25-5CA1
Mains operating voltage 3 AC 380 V to 480 V						
0.37	0.50	2.2	1.2	A	6SE6420-2UD13-7AA1	–
0.55	0.75	2.8	1.6	A	6SE6420-2UD15-5AA1	–
0.75	1.0	3.7	2.1	A	6SE6420-2UD17-5AA1	–
1.1	1.5	4.9	3.0	A	6SE6420-2UD21-1AA1	–
1.5	2.0	5.9	4.0	A	6SE6420-2UD21-5AA1	–
2.2	3.0	7.5	5.9	B	6SE6420-2UD22-2BA1	6SE6420-2AD22-2BA1
3.0	4.0	10.0	7.7	B	6SE6420-2UD23-0BA1	6SE6420-2AD23-0BA1
4.0	5.0	12.8	10.2	B	6SE6420-2UD24-0BA1	6SE6420-2AD24-0BA1
5.5	7.5	15.6	13.2	C	6SE6420-2UD25-5CA1	6SE6420-2AD25-5CA1
7.5	10.0	22.0	19.0	C	6SE6420-2UD27-5CA1	6SE6420-2AD27-5CA1
11	15.0	32.3	26.0	C	6SE6420-2UD31-1CA1	6SE6420-2AD31-1CA1



See Appendix for note on ordering.

All MICROMASTER 420 inverters are supplied with a Status Display Panel (SDP). A BOP, AOP or other options have to be ordered separately (see Pages 2/12 to 2/16).

Motors for MICROMASTER 420

Catalog M 11 contains selection and ordering data for motors which are particularly suitable for operation with the MICROMASTER 420 inverters (see Appendix for overview).

This catalog is suitable for IEC motors. For motors according to US standards (NEMA) please refer to: <http://www.sea.siemens.com/motors>

1) Supplementary conditions: Input current at rated operating point, applicable at short-circuit voltage of the supply $U_{sc} = 2\%$ with reference to the

inverter rated power and rated mains voltage of 240 V or 400 V with a line commutating choke.

2) Use of MICROMASTER inverters with internal filter is not permissible on non-grounded (IT) mains supplies.

3) Generally suited to heavy industrial applications. For details please refer to Appendix on page A/4.

Overview**EMC filter, Class A**

Filter for inverters without an internal filter for

- 3 AC 200 V to 240 V, frame sizes A and B
- 3 AC 380 V to 480 V, frame size A.

All other inverters can be supplied with an internal Class A filter.

The requirements are fulfilled using shielded cables with a max. length of 25 m.

EMC filter, Class B

Filter for inverters without an internal filter for

- 3 AC 200 V to 240 V, frame sizes A and B
- 3 AC 380 V to 480 V, frame size A.

With this filter, the inverter complies with the emission standard EN 55 011, Class B.

The requirements are fulfilled using shielded cables with a max. length of 25 m.

Additional EMC filter, Class B

Available for inverters with an internal Class A EMC filter.

With this filter, the inverter complies with the emission standard EN 55 011, Class B.

The requirements are fulfilled using shielded cables with a max. length of 25 m.

Filter Class B with low leakage currents

EMC filter for 1 AC 200 V to 240 V inverters, frame sizes A and B, without an internal EMC filter Class A.

With this filter, the inverter complies with the emission standard EN 55 011, Class B. The leakage currents are reduced to < 3.5 mA.

The requirements are fulfilled using shielded cables with a max. length of 5 m.

Leakage currents:

The leakage currents of the inverters with/without filter (internal/external) may exceed 30 mA. Typical values in practice are between 10 mA and 50 mA. The exact values depend on the design, environment and cable lengths. Interference-free operation with residual current operated devices with a trigger value of 30 mA cannot be guaranteed. However, operation with residual current circuit-breakers with a trigger value of 300 mA is possible. Please refer to the Instruction Manual for details.

LC filter

The LC filter limits the rate of rise of voltage and the capacitive charge/discharge currents which usually occur with inverter operation. This means that much longer shielded motor cables are possible when using LC filters and the service life of the motor achieves values similar to those with direct mains operation. Use of an output choke isn't required with that.

Please note when using LC filters:

- Only V/f, FCC control permissible
- Please observe the derating of 15% when selecting the appropriate inverter
- Operation only permissible with 4 kHz pulse frequency
- The output frequency is limited to 150 Hz.

The LC filters can be used for all MICROMASTER 420 inverters of frame sizes A to C.

Line commutating choke

Line commutating chokes are used to smooth voltage peaks or to bridge commutating dips. In addition, line commutating chokes reduce the effects of harmonics on the inverter and the power supply. If the line impedance is < 1 %, a line commutating choke must be used in order to reduce the current peaks.

In line with EN 61 000-3-2 regulations "Limits for harmonic currents with device input current ≤ 16 A per phase", there are special aspects for drives with 250 W to 550 W and 230 V single-phase supplies which can be used in non-industrial applications (1st environment).

For devices with 250 W and 370 W, it is necessary either to fit the recommended input chokes or to apply to the power utility company for authorization to connect the devices to the public power supply. No limits are currently defined in the EN 61 000-3-2 standard for professionally used devices with a connected load > 1 kW which means that the inverters with an output power ≥ 0.75 kW comply with the EN 61 000-3-2 standard.

Output choke

Output chokes can be supplied for reducing the capacitive currents and dV/dt in the case of motor cables > 50 m (shielded) or > 100 m (unshielded).

For max. permissible cable lengths, see Technical Data.

Gland plate

The gland plate facilitates the shield connection of power and control cables and ensures optimum EMC performance.

Options Variant dependent options

Technical data

LC filter

Mains voltage	3 AC 380 V to 480 V		
Current (at 40 °C/50 °C)	for frame size A	4.5 A/ 4.1 A	
	for frame size B	11.2 A/10.2 A	
	for frame size C	32.6 A/29.7 A	
Limiting of motor overvoltage	≤ 1078 V		
dV/dt limiting	≤ 500 V/μs		
Pulse frequency	4 kHz		
Max. motor frequency	150 Hz		
Max. permissible motor cable lengths	shielded	200 m	
	unshielded	300 m	
Insulation strength	Overvoltage category III to VDE 0110		
Electromagnetic compatibility	Up to 200 m motor cable length with emissions to Class A according to EN 55 011 in conjunction with filtered inverters and unshielded cables		
Conformity	CE according to the low-voltage directive 73/23/EEC		
Approvals	UL available soon		
Strain resistance	EN 60 068-2-31		
Humidity	95 % humidity, non-condensing		
Degree of protection	IP20 (to EN 60529)		
Insulation class	H (180 °C)		
Permissible temperature	Operation	-10 °C to +40 °C (+14 °F to +104 °F) to +50 °C (to +122 °F)	100 % P_n 80 % P_n
	Storage	-25 °C to +70 °C (-13 °F to +158 °F)	
Operational altitude	up to 2000 m	100 % P_n	
	2000 to 4000 m	62.5 % P_n	
Mounting position	Footprint or suspended		
Free space	Top	100 mm	
	Bottom	100 mm	
	Side	100 mm	
Connection system	Input, litz wire or terminal	1U1, 1V1, 1W1	
	Output, terminals	1U2, 1V2, 1W2	
Torque for power conductor connections	1.5 Nm to 1.8 Nm		
Weight, approx.	for frame size A	7 kg	
	for frame size B	11 kg	
	for frame size C	29 kg	

Max. permissible cable lengths from the motor to the inverter when using output chokes

The following table shows the maximum permissible cable lengths from the motor to the inverter when using output chokes.

Frame size (FS)	Output choke Type	Max. permissible motor cable lengths (shielded/unshielded) for a mains voltage of		
		200 V to 240 V ± 10 %	380 V to 400 V ± 10 %	401 V to 480 V ± 10 %
A	6SE6400-3TC00-4AD3	200 m/300 m	–	–
A	6SE6400-3TC00-4AD2	200 m/300 m	150 m/225 m	100 m/150 m
B	6SE6400-3TC01-0BD3	200 m/300 m	150 m/225 m	100 m/150 m
C	6SE6400-3TC03-2CD3	200 m/300 m	200 m/300 m	100 m/150 m

Design

General installation instructions

- A maximum of two footprint components plus inverter are permissible.
- If an LC filter is used, it must be mounted directly on the wall of the control cabinet due to weight reasons. If an LC filter of frame size C is used, therefore, only one footprint component is permissible. If a line choke and LC filter are used, the line choke must be located on the left of the inverter. Required spacing: 75 mm.
- The EMC filter must be mounted directly below the frequency inverter if possible.
- If mounted on the side, the line-side components are to be mounted to the left of the frequency inverter whereas the output-side components are to be mounted to the right of the frequency inverter.

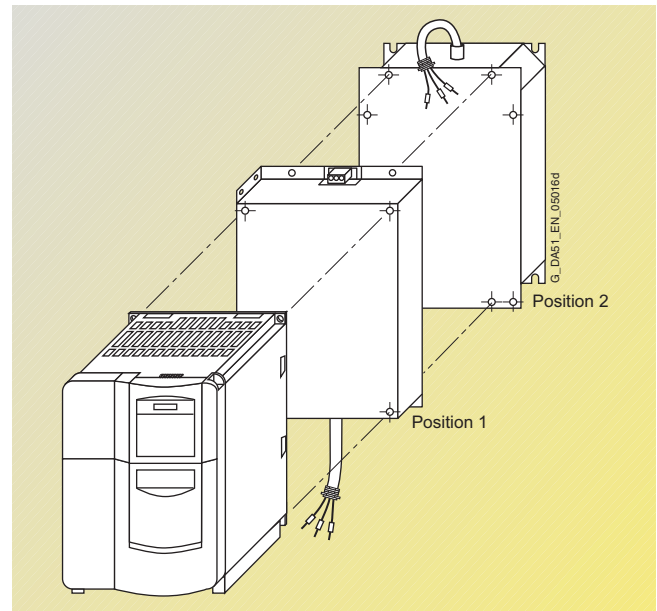

Example of installation with frequency inverter, EMC filter (position 1) and line choke (position 2)

Availability of the options as footprint components

	Frame size		
	A	B	C
Line commutating choke	✓	✓	✓
EMC filter	✓	✓	✓
LC filter	✓	✓	✓
Output choke	✓	✓	✓

Recommended combinations of inverters and options

Frequency inverter Frame size	Footprint		Mounted on side	
	Position 1	Position 2	To the left of the inverter (for line-side components)	To the right of the inverter (for output-side components)
A and B	EMC filter	Line commutating choke	–	Output choke
	EMC filter <u>or</u> Line commutating choke	Output choke <u>or</u> LC filter	–	–
C	EMC filter	Line commutating choke	–	Output choke
	EMC filter <u>or</u> Line commutating choke	Output choke	–	–
	LC filter	–	EMC filter <u>and/or</u> Line commutating choke	–

MICROMASTER 420

Options

Variant dependent options

Selection and ordering data

The options listed here (filters, chokes, gland plates, fuses, and circuit-breakers) must be selected to match the inverter.

The inverter and the associated options have the same voltage ratings.

All options are certified to , except fuses. The fuses of Type 3NA3 are recommended for Europe.

Use in America requires @-listed fuses such as the Class NON range from Bussmann.

Mains voltage	Output		Inverter without filter	Order No. of the options		
	kW	hp		EMC filter Class A	EMC filter Class B	Additional EMC filter, Class B
1 AC 200 V to 240 V	0.12	0.16	6SE6420-2UC11-2AA1	–	6SE6400-2FL01-0AB0 with low leakage currents	–
	0.25	0.33	6SE6420-2UC12-5AA1	–		–
	0.37	0.50	6SE6420-2UC13-7AA1	–		–
	0.55	0.75	6SE6420-2UC15-5AA1	–	–	–
	0.75	1.0	6SE6420-2UC17-5AA1	–	–	–
	1.1	1.5	6SE6420-2UC21-1BA1	–	6SE6400-2FL02-6BB0 with low leakage currents	–
	1.5	2.0	6SE6420-2UC21-5BA1	–		–
	2.2	3.0	6SE6420-2UC22-2BA1	–		–
	3.0	4.0	6SE6420-2UC23-0CA1	–	–	–
3 AC 200 V to 240 V	0.12	0.16	6SE6420-2UC11-2AA1	6SE6400-2FA00-6AD0	6SE6400-2FB00-6AD0	–
	0.25	0.33	6SE6420-2UC12-5AA1	–	–	–
	0.37	0.50	6SE6420-2UC13-7AA1	–	–	–
	0.55	0.75	6SE6420-2UC15-5AA1	–	–	–
	0.75	1.0	6SE6420-2UC17-5AA1	–	–	–
	1.1	1.5	6SE6420-2UC21-1BA1	6SE6400-2FA01-4BC0	6SE6400-2FB01-4BC0	–
	1.5	2.0	6SE6420-2UC21-5BA1	–	–	–
	2.2	3.0	6SE6420-2UC22-2BA1	–	–	–
	3.0	4.0	6SE6420-2UC23-0CA1	–	–	–
	4.0	5.0	6SE6420-2UC24-0CA1	–	–	–
	5.5	7.5	6SE6420-2UC25-5CA1	–	–	–
3 AC 380 V to 480 V	0.37	0.50	6SE6420-2UD13-7AA1	6SE6400-2FA00-6AD0	6SE6400-2FB00-6AD0	–
	0.55	0.75	6SE6420-2UD15-5AA1	–	–	–
	0.75	1.0	6SE6420-2UD17-5AA1	–	–	–
	1.1	1.5	6SE6420-2UD21-1AA1	–	–	–
	1.5	2.0	6SE6420-2UD21-5AA1	–	–	–
	2.2	3.0	6SE6420-2UD22-2BA1	–	–	–
	3.0	4.0	6SE6420-2UD23-0BA1	–	–	–
	4.0	5.0	6SE6420-2UD24-0BA1	–	–	–
	5.5	7.5	6SE6420-2UD25-5CA1	–	–	–
	7.5	10.0	6SE6420-2UD27-5CA1	–	–	–
	11	15.0	6SE6420-2UD31-1CA1	–	–	–
			Inverter with internal filter Class A			
1 AC 200 V to 240 V	0.12	0.16	6SE6420-2AB11-2AA1	–	–	6SE6400-2FS01-0AB0
	0.25	0.33	6SE6420-2AB12-5AA1	–	–	–
	0.37	0.50	6SE6420-2AB13-7AA1	–	–	–
	0.55	0.75	6SE6420-2AB15-5AA1	–	–	–
	0.75	1.0	6SE6420-2AB17-5AA1	–	–	–
	1.1	1.5	6SE6420-2AB21-1BA1	–	–	6SE6400-2FS02-6BB0
	1.5	2.0	6SE6420-2AB21-5BA1	–	–	–
	2.2	3.0	6SE6420-2AB22-2BA1	–	–	–
	3.0	4.0	6SE6420-2AB23-0CA1	–	–	6SE6400-2FS03-5CB0
3 AC 200 V to 240 V	3.0	4.0	6SE6420-2AC23-0CA1	–	–	6SE6400-2FS03-8CD0
	4.0	5.0	6SE6420-2AC24-0CA1	–	–	–
	5.5	7.5	6SE6420-2AC25-5CA1	–	–	–
3 AC 380 V to 480 V	2.2	3.0	6SE6420-2AD22-2BA1	–	–	6SE6400-2FS01-6BD0
	3.0	4.0	6SE6420-2AD23-0BA1	–	–	–
	4.0	5.0	6SE6420-2AD24-0BA1	–	–	–
	5.5	7.5	6SE6420-2AD25-5CA1	–	–	6SE6400-2FS03-8CD0
	7.5	10.0	6SE6420-2AD27-5CA1	–	–	–
11	15.0	6SE6420-2AD31-1CA1	–	–	–	

Selection and ordering data (continued)

Mains voltage	Output		Inverter without filter	Order No. of the options			
	kW	hp		Line commutating choke	LC filter	Output choke	
1 AC 200 V to 240 V	0.12	0.16	6SE6420-2UC11-2AA1	6SE6400-3CC00-4AB3	–	6SE6400-3TC00-4AD3	
	0.25	0.33	6SE6420-2UC12-5AA1	–	–	–	
	0.37	0.50	6SE6420-2UC13-7AA1	6SE6400-3CC01-0AB3	–	–	
	0.55	0.75	6SE6420-2UC15-5AA1	–	–	–	
	0.75	1.0	6SE6420-2UC17-5AA1	–	–	–	
	1.1	1.5	6SE6420-2UC21-1BA1	6SE6400-3CC02-6BB3	–	6SE6400-3TC01-0BD3	
	1.5	2.0	6SE6420-2UC21-5BA1	–	–	–	
	2.2	3.0	6SE6420-2UC22-2BA1	–	–	–	
	3.0	4.0	6SE6420-2UC23-0CA1	6SE6400-3CC03-5CB3	–	6SE6400-3TC03-2CD3	
3 AC 200 V to 240 V	0.12	0.16	6SE6420-2UC11-2AA1	6SE6400-3CC00-3AC3	–	6SE6400-3TC00-4AD3	
	0.25	0.33	6SE6420-2UC12-5AA1	–	–	–	
	0.37	0.50	6SE6420-2UC13-7AA1	6SE6400-3CC00-5AC3	–	–	
	0.55	0.75	6SE6420-2UC15-5AA1	–	–	–	
	0.75	1.0	6SE6420-2UC17-5AA1	–	–	–	
	1.1	1.5	6SE6420-2UC21-1BA1	6SE6400-3CC00-8BC3	–	6SE6400-3TC01-0BD3	
	1.5	2.0	6SE6420-2UC21-5BA1	6SE6400-3CC01-4BD3	–	–	
	2.2	3.0	6SE6420-2UC22-2BA1	–	–	–	
	3.0	4.0	6SE6420-2UC23-0CA1	6SE6400-3CC01-7CC3	–	6SE6400-3TC03-2CD3	
3 AC 200 V to 240 V	4.0	5.0	6SE6420-2UC24-0CA1	6SE6400-3CC03-5CD3	–	–	
	5.5	7.5	6SE6420-2UC25-5CA1	–	–	–	
	0.37	0.50	6SE6420-2UD13-7AA1	6SE6400-3CC00-2AD3	6SE6400-3TD00-4AD0	6SE6400-3TC00-4AD2	
	0.55	0.75	6SE6420-2UD15-5AA1	–	–	–	
	0.75	1.0	6SE6420-2UD17-5AA1	6SE6400-3CC00-4AD3	–	–	
	1.1	1.5	6SE6420-2UD21-1AA1	–	–	–	
	1.5	2.0	6SE6420-2UD21-5AA1	6SE6400-3CC00-6AD3	–	–	
	2.2	3.0	6SE6420-2UD22-2BA1	6SE6400-3CC01-0BD3	6SE6400-3TD01-0BD0	6SE6400-3TC01-0BD3	
	3.0	4.0	6SE6420-2UD23-0BA1	–	–	–	
3 AC 380 V to 480 V	4.0	5.0	6SE6420-2UD24-0BA1	6SE6400-3CC01-4BD3	–	–	
	5.5	7.5	6SE6420-2UD25-5CA1	6SE6400-3CC02-2CD3	6SE6400-3TD03-2CD0	6SE6400-3TC03-2CD3	
	7.5	10.0	6SE6420-2UD27-5CA1	–	–	–	
	11	15.0	6SE6420-2UD31-1CA1	6SE6400-3CC03-5CD3	–	–	
				Inverter with internal filter Class A			
	1 AC 200 V to 240 V	0.12	0.16	6SE6420-2AB11-2AA1	6SE6400-3CC00-4AB3	–	6SE6400-3TC00-4AD3
		0.25	0.33	6SE6420-2AB12-5AA1	–	–	–
		0.37	0.50	6SE6420-2AB13-7AA1	6SE6400-3CC01-0AB3	–	–
		0.55	0.75	6SE6420-2AB15-5AA1	–	–	–
0.75		1.0	6SE6420-2AB17-5AA1	–	–	–	
1.1		1.5	6SE6420-2AB21-1BA1	6SE6400-3CC02-6BB3	–	6SE6400-3TC01-0BD3	
1.5		2.0	6SE6420-2AB21-5BA1	–	–	–	
2.2		3.0	6SE6420-2AB22-2BA1	–	–	–	
3.0		4.0	6SE6420-2AB23-0CA1	6SE6400-3CC03-5CB3	–	6SE6400-3TC03-2CD3	
3 AC 200 V to 240 V	3.0	4.0	6SE6420-2AC23-0CA1	6SE6400-3CC01-7CC3	–	6SE6400-3TC03-2CD3	
	4.0	5.0	6SE6420-2AC24-0CA1	6SE6400-3CC03-5CD3	–	–	
	5.5	7.5	6SE6420-2AC25-5CA1	–	–	–	
3 AC 380 V to 480 V	2.2	3.0	6SE6420-2AD22-2BA1	6SE6400-3CC01-0BD3	6SE6400-3TD01-0BD0	6SE6400-3TC01-0BD3	
	3.0	4.0	6SE6420-2AD23-0BA1	–	–	–	
	4.0	5.0	6SE6420-2AD24-0BA1	6SE6400-3CC01-4BD3	–	–	
	5.5	7.5	6SE6420-2AD25-5CA1	6SE6400-3CC02-2CD3	6SE6400-3TD03-2CD0	6SE6400-3TC03-2CD3	
	7.5	10.0	6SE6420-2AD27-5CA1	–	–	–	
11	15.0	6SE6420-2AD31-1CA1	6SE6400-3CC03-5CD3	–	–		

MICROMASTER 420

Options Variant dependent options

Selection and ordering data (continued)

Mains voltage	Output		Inverter without filter	Order No. of the options		
	kW	hp		Gland plate	Fuse (see Catalog LV 10)	Circuit-breaker
1 AC 200 V to 240 V	0.12	0.16	6SE6420-2UC11-2AA1	6SE6400-0GP00-0AA0	3NA3803	3RV1021-1DA10
	0.25	0.33	6SE6420-2UC12-5AA1			3RV1021-1GA10
	0.37	0.50	6SE6420-2UC13-7AA1			3RV1021-1HA10
	0.55	0.75	6SE6420-2UC15-5AA1			3RV1021-1JA10
	0.75	1.0	6SE6420-2UC17-5AA1	3NA3805	3RV1021-4AA10	
	1.1	1.5	6SE6420-2UC21-1BA1	6SE6400-0GP00-0BA0	3NA3807	3RV1021-4BA10
	1.5	2.0	6SE6420-2UC21-5BA1			3RV1021-4DA10
	2.2	3.0	6SE6420-2UC22-2BA1	3NA3812	3RV1031-4FA10	
	3.0	4.0	6SE6420-2UC23-0CA1	6SE6400-0GP00-0CA0	3NA3817	3RV1031-4HA10
	3 AC 200 V to 240 V	0.12	0.16	6SE6420-2UC11-2AA1	6SE6400-0GP00-0AA0	3NA3803
0.25		0.33	6SE6420-2UC12-5AA1	3RV1021-1DA10		
0.37		0.50	6SE6420-2UC13-7AA1	3RV1021-1EA10		
0.55		0.75	6SE6420-2UC15-5AA1	3RV1021-1GA10		
0.75		1.0	6SE6420-2UC17-5AA1	3RV1021-1HA10		
1.1		1.5	6SE6420-2UC21-1BA1	6SE6400-0GP00-0BA0	3NA3805	3RV1021-1KA10
1.5		2.0	6SE6420-2UC21-5BA1			3RV1021-4AA10
2.2		3.0	6SE6420-2UC22-2BA1	3NA3807	3RV1021-4BA10	
3.0		4.0	6SE6420-2UC23-0CA1	6SE6400-0GP00-0CA0	3NA3810	3RV1021-4CA10
4.0		5.0	6SE6420-2UC24-0CA1	3NA3812	3RV1031-4EA10	
5.5	7.5	6SE6420-2UC25-5CA1	3NA3814	3RV1031-4FA10		
3 AC 380 V to 480 V	0.37	0.50	6SE6420-2UD13-7AA1	6SE6400-0GP00-0AA0	3NA3803	3RV1021-1CA10
	0.55	0.75	6SE6420-2UD15-5AA1			3RV1021-1DA10
	0.75	1.0	6SE6420-2UD17-5AA1			3RV1021-1EA10
	1.1	1.5	6SE6420-2UD21-1AA1			3RV1021-1GA10
	1.5	2.0	6SE6420-2UD21-5AA1	3RV1021-1HA10		
	2.2	3.0	6SE6420-2UD22-2BA1	6SE6400-0GP00-0BA0	3NA3805	3RV1021-1JA10
	3.0	4.0	6SE6420-2UD23-0BA1			3RV1021-1KA10
	4.0	5.0	6SE6420-2UD24-0BA1	3NA3807	3RV1021-4AA10	
	5.5	7.5	6SE6420-2UD25-5CA1	6SE6400-0GP00-0CA0	3RV1021-4CA10	
	7.5	10.0	6SE6420-2UD27-5CA1	3NA3810	3RV1031-4EA10	
11	15.0	6SE6420-2UD31-1CA1	3NA3814	3RV1031-4GA10		
			Inverter with internal filter Class A			
1 AC 200 V to 240 V	0.12	0.16	6SE6420-2AB11-2AA1	6SE6400-0GP00-0AA0	3NA3803	3RV1021-1DA10
	0.25	0.33	6SE6420-2AB12-5AA1			3RV1021-1GA10
	0.37	0.50	6SE6420-2AB13-7AA1			3RV1021-1HA10
	0.55	0.75	6SE6420-2AB15-5AA1			3RV1021-1JA10
	0.75	1.0	6SE6420-2AB17-5AA1	3NA3805	3RV1021-4AA10	
	1.1	1.5	6SE6420-2AB21-1BA1	6SE6400-0GP00-0BA0	3NA3807	3RV1021-4BA10
	1.5	2.0	6SE6420-2AB21-5BA1			3RV1021-4DA10
	2.2	3.0	6SE6420-2AB22-2BA1	3NA3812	3RV1031-4FA10	
	3.0	4.0	6SE6420-2AB23-0CA1	6SE6400-0GP00-0CA0	3NA3817	3RV1031-4HA10
	3 AC 200 V to 240 V	3.0	4.0	6SE6420-2AC23-0CA1	6SE6400-0GP00-0CA0	3NA3810
4.0		5.0	6SE6420-2AC24-0CA1	3NA3812	3RV1031-4EA10	
5.5		7.5	6SE6420-2AC25-5CA1	3NA3814	3RV1031-4FA10	
3 AC 380 V to 480 V	2.2	3.0	6SE6420-2AD22-2BA1	6SE6400-0GP00-0BA0	3NA3805	3RV1021-1JA10
	3.0	4.0	6SE6420-2AD23-0BA1			3RV1021-1KA10
	4.0	5.0	6SE6420-2AD24-0BA1	3NA3807	3RV1021-4AA10	
	5.5	7.5	6SE6420-2AD25-5CA1	6SE6400-0GP00-0CA0	3RV1021-4CA10	
	7.5	10.0	6SE6420-2AD27-5CA1	3NA3810	3RV1031-4EA10	
	11	15.0	6SE6420-2AD31-1CA1	3NA3814	3RV1031-4GA10	

Overview

Basic Operator Panel (BOP)

With the BOP, individual parameter settings can be made. Values and units are shown on a 5-digit display.



Basic Operator Panel (BOP)

A BOP can be used for several inverters. It can be directly mounted on the inverter or in a control cabinet door using a mounting kit.

Advanced Operator Panel (AOP)

The AOP enables parameter kits to be read out of the inverter or to be written into the inverter (upload/download). Different parameter kits can be stored in the AOP. It has a plain text display with the possibility of switching between several languages.



Advanced Operator Panel (AOP)

Up to 30 inverters can be controlled from an AOP via USS. It can be directly mounted on the inverter or in a control cabinet door using a mounting kit.

Asian Advanced Operator Panel (AAOP)

The AAOP is the Chinese version of the AOP operator panel. It has an enhanced display and supports the operating languages of Chinese (simplified) and English.



Asian Advanced Operator Panel (AAOP)

PROFIBUS module

For a complete PROFIBUS connection with up to ≤ 12 Mbaud. Remote control of the inverter is possible with the PROFIBUS module. Remote control and operation at the inverter can be combined using an operator panel plugged onto the PROFIBUS module. The PROFIBUS module can be supplied by an external 24 V DC power supply and is thus also active when the inverter is disconnected from the power supply.

Connection by means of a 9-pin Sub-D connector (available as an option).

DeviceNet module

For networking the inverters to the DeviceNet fieldbus system widely used on the American market. A maximum transmission rate of 500 Kbaud is possible. Remote control of the inverter is possible with the DeviceNet module. Remote control and operation at the inverter can be combined using an operator panel plugged onto the DeviceNet module.

The connection to the DeviceNet bus system is made using a 5-pin connector with terminal strip.

CANopen module

Using the CANopen communications module, an inverter can be linked to the CANopen fieldbus system and remote control is then possible.

Remote control and operation at the inverter can be combined using an operator panel plugged onto the CANopen module.

The module is connected to the bus system through a 9-pin Sub-D connector.

Connection kit for PC to inverter

For controlling an inverter directly from a PC if the appropriate software has been installed (e.g. STARTER). Isolated RS-232 adapter module for reliable point-to-point connection to a PC. Includes a Sub-D connector and an RS-232 standard cable (3 m).

Connection kit for PC to AOP

For connecting a PC to an AOP or AAOP. Offline programming of inverters and archiving of parameter kits possible. Includes a desktop attachment kit for an AOP or AAOP, an RS-232 standard cable (3 m) with Sub-D connectors and a universal power supply unit.

Operator panel door mounting kit for single inverter

For mounting an operator panel in a control cabinet door. Degree of protection IP56. Contains a cable adapter module with screwless terminals for use with user's own RS-232-cables¹⁾.

AOP door mounting kit for multiple inverters (USS)

For mounting an AOP or AAOP in a control cabinet door. Degree of protection IP56. The AOP or AAOP can communicate with several inverters by means of the RS-485 USS protocol. The 4-pin connecting cable from the AOP or AAOP to the RS-485 terminals of the inverter and to the 24 V user terminal strip is not included²⁾.

Start-up tools

- **STARTER** is a graphic start-up software for guided start-up for MICROMASTER 410/420/430/440 frequency inverters under Windows NT/2000/XP Professional. Parameter lists can be read out, altered, stored, entered and printed.
- **DriveMonitor** is a start-up software for list-oriented programming of frequency inverters. This program executes under Windows 98/NT/2000/ME/XP Professional.

Both programs are included on the Docu CD which is provided with every inverter.

1) A shielded cable of type Belden 8132 (28 AWG) is recommended. The maximum cable length is 5 m for RS-232.

2) A shielded cable of type Belden 8132 (28 AWG) is recommended. The maximum cable length is 10 m for RS-485.

Options Variant independent options

Selection and ordering data

The options listed here are suitable for all MICROMASTER 420 inverters.

Options	Order No.
Basic Operator Panel (BOP)	6SE6400-0BP00-0AA0
Advanced Operator Panel (AOP)	6SE6400-0AP00-0AA1
Asian Advanced Operator Panel (AAOP)	6SE6400-0AP00-0AB0
PROFIBUS module	6SE6400-1PB00-0AA0
DeviceNet module	6SE6400-1DN00-0AA0
CANopen module	6SE6400-1CB00-0AA0
RS485/PROFIBUS bus connector	6GK1500-0FC00
Connection kit for PC to inverter	6SE6400-1PC00-0AA0
Connection kit for PC to AOP	6SE6400-0PA00-0AA0
Operator panel door mounting kit for single inverter	6SE6400-0PM00-0AA0
AOP door mounting kit for multiple inverters (USS)	6SE6400-0MD00-0AA0
Start-up tool STARTER on CD-ROM	6SL3072-0AA00-0AG0

Available on the Internet at:
<http://www4.ad.siemens.de/WW/view/com/10804985/133100>

Technical data of the communication modules

	PROFIBUS module 6SE6400-1PB00-0AA0	DeviceNet module 6SE6400-1DN00-0AA0
		
Size (height x width x depth)	161 mm x 73 mm x 46 mm	
Degree of protection	IP20	
Degree of pollution	2 to IEC 60664-1 (DIN VDE 0110/T1), no condensation permitted during operation	
Strain resistance	to DIN IEC 60068-2-6 (if module is installed correctly)	
• Stationary	Deflection Acceleration 0.15 mm in the frequency range of 10 Hz to 58 Hz 19.6 m/s ² in the frequency range of 58 Hz to 500 Hz	
• Transport	Deflection Acceleration 3.5 mm in the frequency range of 5 Hz to 9 Hz 9.8 m/s ² in the frequency range of 9 Hz to 500 Hz	
Climatic category (during operation)	3K3 to DIN IEC 60721-3-3	
Cooling method	Natural air cooling	
Permissible ambient or cooling agent temperature	-10 °C to +50 °C (+14 °F to +122 °F)	
• Operation	-25 °C to +70 °C (-13 °F to +158 °F)	
• Storage and transport		
Relative humidity (permissible humidity rating)	≤ 85 % (non-condensing)	
• Operation	≤ 95 %	
• Storage and transport		
Electromagnetic compatibility	Emission Interference	to EN 55011 (1991) Class A to IEC 60801-3 and EN 61000-4-3
Power supply	6.5 V ± 5 %, max. 300 mA, internal from inverter or 24 V ± 10 %, max. 350 mA, external	6.5 V ± 5 %, max. 300 mA internal from inverter or 24 V, max. 60 mA from DeviceNet-Bus
Output voltage	5 V ± 10 %, max. 100 mA, galvanically isolated supply • for terminating the serial interface bus or • for supplying the OLP (Optical Link Plug)	-
Data transmission rate	max. 12 Mbaud	125, 250 and 500 Kbaud

Technical data of the communication modules (continued)

CANopen module
6SE6400-1CB00-0AA0



Size (height x width x depth)	161 mm x 73 mm x 46 mm
Degree of protection	IP20
Degree of pollution	2 to IEC 60664-1 (DIN VDE 0110/T1), no condensation permitted during operation
Strain resistance	to IEC 60068-2-6 (if module is installed correctly)
• Stationary	Deflection 0.15 mm in the frequency range of 10 Hz to 58 Hz
• Transport	Acceleration 19.6 m/s ² in the frequency range of 58 Hz to 500 Hz Deflection 3.5 mm in the frequency range of 5 Hz to 9 Hz Acceleration 9.8 m/s ² in the frequency range of 9 Hz to 500 Hz
Climatic category (during operation)	3K3 to DIN IEC 60721-3-3
Cooling method	Natural air cooling
Permissible ambient or cooling agent temperature	
• Operation	-10 °C to +50 °C (+14 °F to +122 °F)
• Storage	-40 °C to +70 °C (-40 °F to +158 °F)
• Transport	-25 °C to +70 °C (-13 °F to +158 °F)
Relative humidity (permissible humidity rating)	
• Operation	≤ 85 % (non-condensing)
• Storage and transport	≤ 95 %
Power supply	The CAN bus is supplied from the inverter power supply
Data transmission rate	10, 20, 50, 125, 250, 500, 800 Kbaud and 1 Mbaud

Documentation

Selection and ordering data

Type of documentation	Language	Order No.
Docu pack , supplied with each inverter, containing CD-ROM ¹⁾ and Getting Started Guide ²⁾ (paper version)	Multilanguage	6SE6400-5AD00-1AP1
Operating instructions²⁾ (paper version)	German	6SE6400-5AA00-0AP0
	English	6SE6400-5AA00-0BP0
	French	6SE6400-5AA00-0DP0
	Italian	6SE6400-5AA00-0CP0
	Spanish	6SE6400-5AA00-0EP0
Parameter list²⁾ (paper version)	German	6SE6400-5BA00-0AP0
	English	6SE6400-5BA00-0BP0
	French	6SE6400-5BA00-0DP0
	Italian	6SE6400-5BA00-0CP0
	Spanish	6SE6400-5BA00-0EP0

1) The CD-ROM contains operating instructions, parameter list, commissioning tools STARTER and DriveMonitor, multilanguage.

Available on the Internet:
DriveMonitor at
<http://www4.ad.siemens.de/WW/view/com/10804984/133100>

STARTER at
<http://www4.ad.siemens.de/WW/view/com/10804985/133100>

2) Available on the Internet at
<http://www.siemens.com/micromaster>

MICROMASTER 420

Dimension drawings

MICROMASTER 420 inverter

Frame size	1/3 AC 200 V to 240 V	3 AC 380 V to 480 V
A	0.12 kW to 0.75 kW	0.37 kW to 1.5 kW
B	1.1 kW to 2.2 kW	2.2 kW to 4 kW
C	3 kW to 5.5 kW	5.5 kW to 11 kW

Note:
The inverters must not be mounted horizontally.
But the inverters can be mounted without lateral spacing.

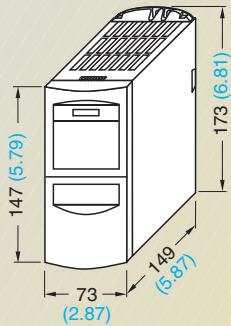

Inverter frame size **A**

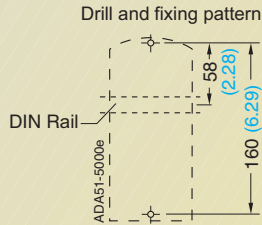

Fixing with
2 x M4 bolts, 2 x M4 nuts, 2 x M4 washers,
or snap onto the DIN rail
Tightening torque with washers fitted:
2.5 Nm

Ventilation clearance required at top and
bottom: 100 mm

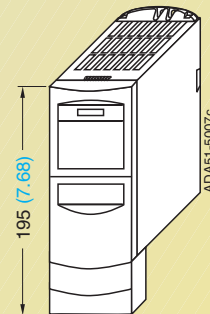

Inverter frame size **A**
with **gland plate**

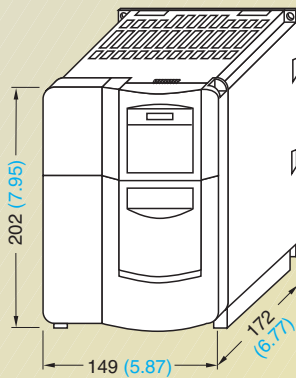

Inverter frame size **B**

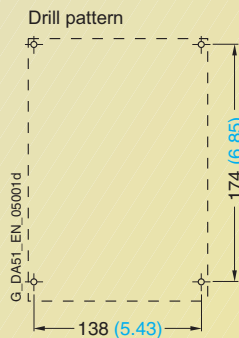

Fixing with
4 x M4 bolts, 4 x M4 nuts, 4 x M4 washers
Tightening torque with washers fitted:
2.5 Nm

Ventilation clearance required at top and
bottom: 100 mm

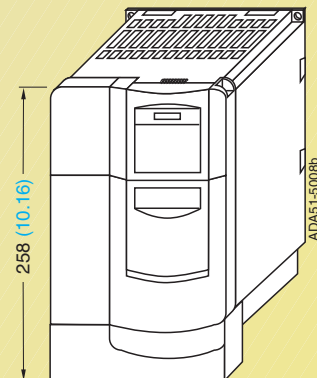

Inverter frame size **B**
with **gland plate**

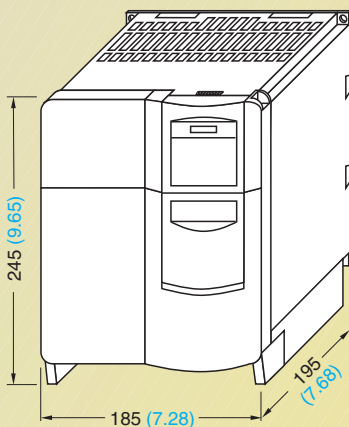

Inverter frame size **C**

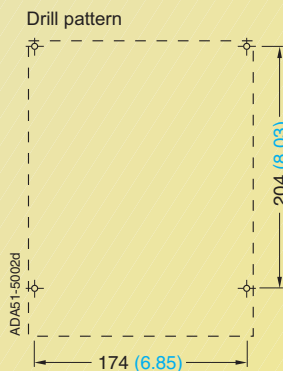

Fixing with
4 x M5 bolts, 4 x M5 nuts, 4 x M5 washers
Tightening torque with washers fitted:
3.0 Nm

Ventilation clearance required at top
and bottom: 100 mm

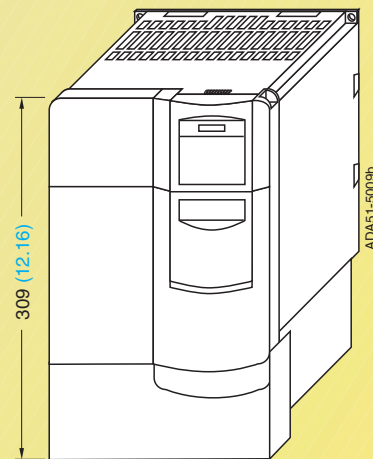

Inverter frame size **C**
with **gland plate**

With the communications module, the mounting depth
increases by 23 mm (0.91 inches).

All dimensions in mm (values in brackets are in inches)

Filters and chokes

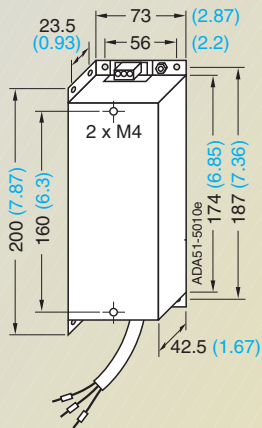

Filter frame size **A**

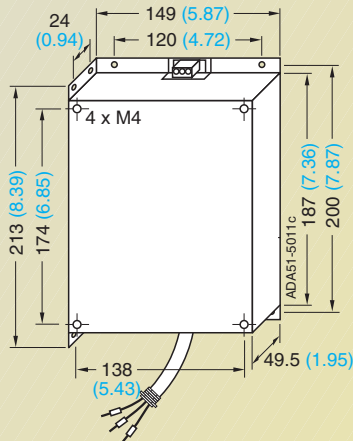

For frame size **B**

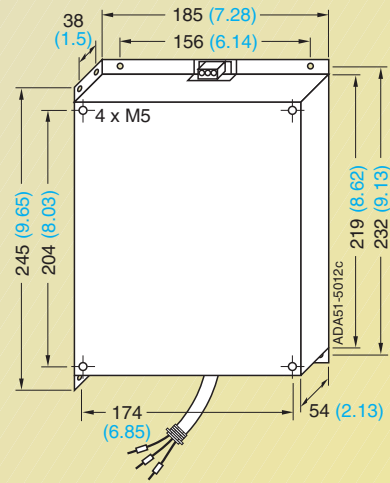

For frame size **C**

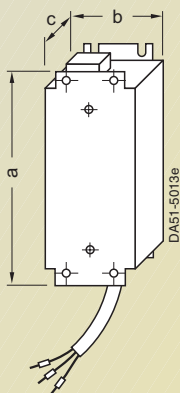

Line commutating choke for frame size **A**

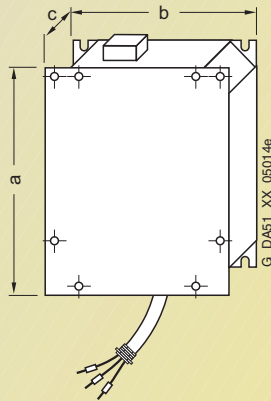

For frame sizes **B** and **C**

Line commutating choke for	Dimensions			Weight (max.) kg
	a	b	c	
Frame size A	200 (7.87)	75.5 (2.97)	50 (1.97)	0.8
Frame size B	213 (8.39)	150 (5.91)	50 (1.97)	1.3
Frame size C	280 (11.02)	185 (7.28)	50 (1.97)	2.3

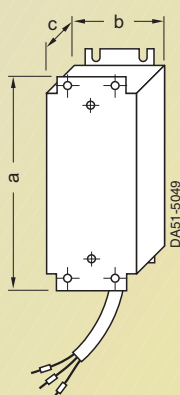

Output choke for frame size **A**
6SE6400-3TC00-4AD2
6SE6400-3TC00-4AD3

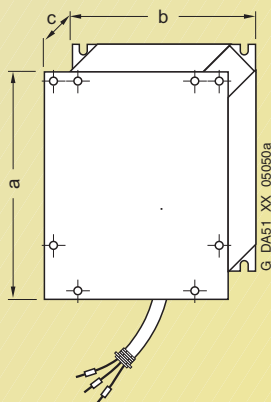

For frame sizes **B** and **C**
6SE6400-3TC01-0BD3
6SE6400-3TC03-2CD3

Output choke type 6SE6400-	Dimensions			Weight (max.) kg
	a	b	c	
3TC00-4AD2	200 (7.87)	75.5 (2.97)	110 (4.33)	1.95
3TC00-4AD3	200 (7.87)	75.5 (2.97)	50 (1.97)	0.8
3TC01-0BD3	213 (8.39)	150 (5.91)	70 (2.76)	3.4
3TC03-2CD3	245 (9.65)	185 (7.28)	80 (3.15)	5.6

All dimensions in mm (values in brackets are in inches)

Dimension drawings

LC filter

2

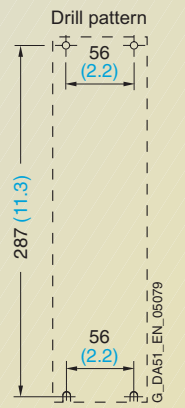
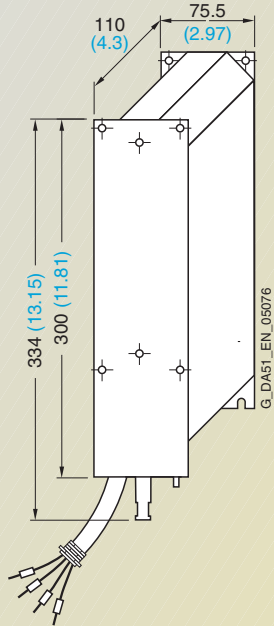

Fixing with M4 bolts

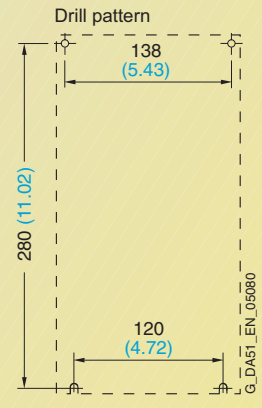
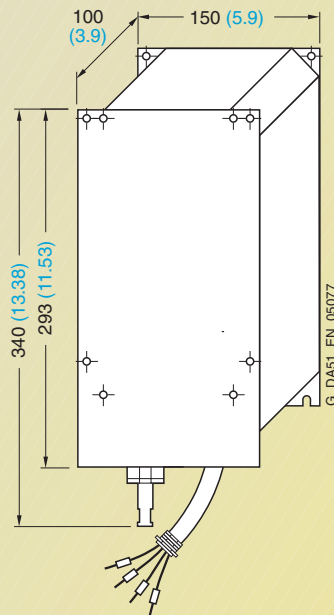

Fixing with M4 bolts

LC filter for frame size A

LC filter for frame size B

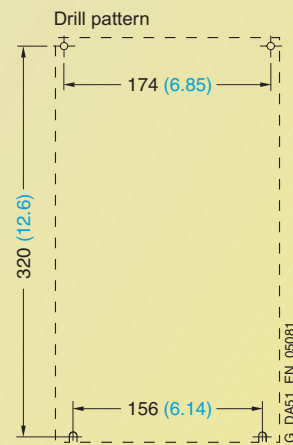
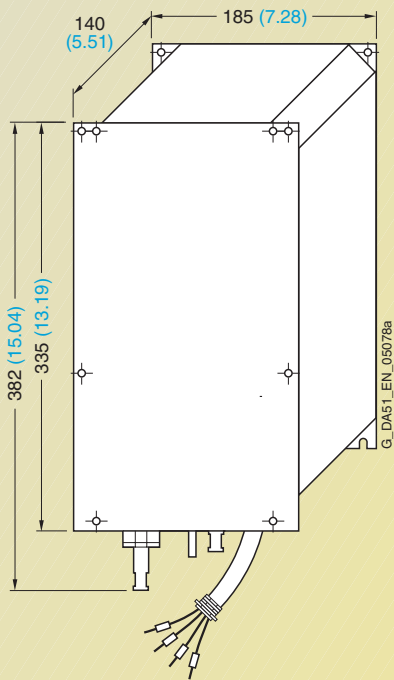

Fixing with M5 bolts

LC filter for frame size C

All dimensions in mm (values in brackets are in inches)

Inverter

MICROMASTER 430



3/2	Description
3/4	Circuit diagrams
3/6	Technical data
3/9	Selection and ordering data
3/10	Options
3/19	Dimension drawings

Description



Applications

The MICROMASTER 430 inverter is suitable for a variety of variable-speed drive applications. Its flexibility provides for a wide spectrum of applications. It is especially suitable for use with industrial pumps and fans. The inverter is especially characterized by its customer-oriented performance and ease-of-use. It has more inputs and outputs than the MICROMASTER 420, an optimized operator panel with manual/automatic switchover and adapted software functionality.

Design

The MICROMASTER 430 inverter has a modular design.

The operator panels and communication modules can be easily exchanged.

Main characteristics

- Easy, guided start-up
- Modular construction allows maximum configuration flexibility
- Six programmable isolated digital inputs
- Two scaleable analog inputs (0 V to 10 V, 0 mA to 20 mA) can also be used as a 7th/8th digital input
- Two programmable analog outputs (0 mA to 20 mA)
- Three programmable relay outputs (30 V DC/5 A resistive load; 250 V AC/2A inductive load)
- Low-noise motor operation thanks to high pulse frequencies, adjustable (observe derating if necessary)
- Complete protection for motor and inverter
- Control of up to three additional drives on the basis of PID control (motor staging)
- Operation of drive directly on mains (with external bypass circuit)
- Low-energy mode
- Detects dry run of pumps (belt failure detection).

Options (overview)

- Line commutating chokes
- Output chokes
- LC filter and sinusoidal filter
- Gland plates
- Basic Operator Panel 2 (BOP-2) for parameterizing the inverter
- Communication modules
 - PROFIBUS
 - DeviceNet
 - CANopen
- PC connection kits
- Mounting kits for installing the operator panels in the control cabinet doors
- PC start-up tools executable under Windows 98 and NT/2000/ME/XP Professional.
- TIA integration with Drive ES

International standards

- The MICROMASTER 430 inverter complies with the requirements of the EU low-voltage guideline
- The MICROMASTER 430 inverter has the **CE** marking
- acc. to **UL** and **cUL** certified
- c-tick **CE**

Note:

See Appendix for standards.

Mechanical features

- Modular design
- Operating temperature
–10 °C to +40 °C
(+14 °F to +104 °F)
- Compact housing as a result of high power density
- Easy cable connection, mains and motor connections are separated for optimum electromagnetic compatibility
- Detachable operator panels
- Screwless control terminal strip on detachable I/O board.

Performance features

- Latest IGBT technology
- Digital microprocessor control
- Flux Current Control (FCC) for improved dynamic response and optimized motor control
- Linear V/f characteristic
- Quadratic V/f characteristic
- Multipoint characteristic (programmable V/f characteristic)
- Flying restart
- Slip compensation
- Automatic restart following mains failure or fault
- Energy saving mode (stopping e.g. of a pump at low speeds)
- Motor staging (connection and disconnection of additional motors, use of inverter as control drive in a pump cascade)
- Manual/automatic mode
- Load torque monitoring (detects dry run of pumps)
- High-grade internal PID controller for simple process control
- Programmable acceleration/deceleration times from 0 s to 650 s
- Ramp smoothing
- Fast Current Limit (FCL) for trip-free operation
- Fast, repeatable digital input response time
- Fine adjustment using two high-resolution 10-bit analog inputs
- Compound braking for controlled rapid braking
- Four skip frequencies
- Removable “Y” capacitor for use on IT systems (with non-grounded mains supplies, the “Y” capacitor must be removed and an output choke installed).

Protection features

- Overload capability
7.5 kW to 90 kW:
Overload current 1.4 x rated output current (i.e. +140 % overload capability) for 3 s, and 1.1 x rated output current (i.e. 110 % overload capability) for 60 s, cycle time 300 s
- 110 kW to 250 kW:
Overload current 1.5 x rated output current (i.e. 150 % overload capability) for 1 s, and 1.1 x rated output current (i.e. 110 % overload capability) for 59 s, cycle time 300 s
- Overvoltage/undervoltage protection
- Inverter overtemperature protection
- Special direct connection for PTC or KTY to protect the motor
- Earth fault protection
- Short-circuit protection
- f_t motor thermal protection
- Locked motor protection
- Stall prevention
- Parameter interlock

Circuit diagrams

General circuit diagram

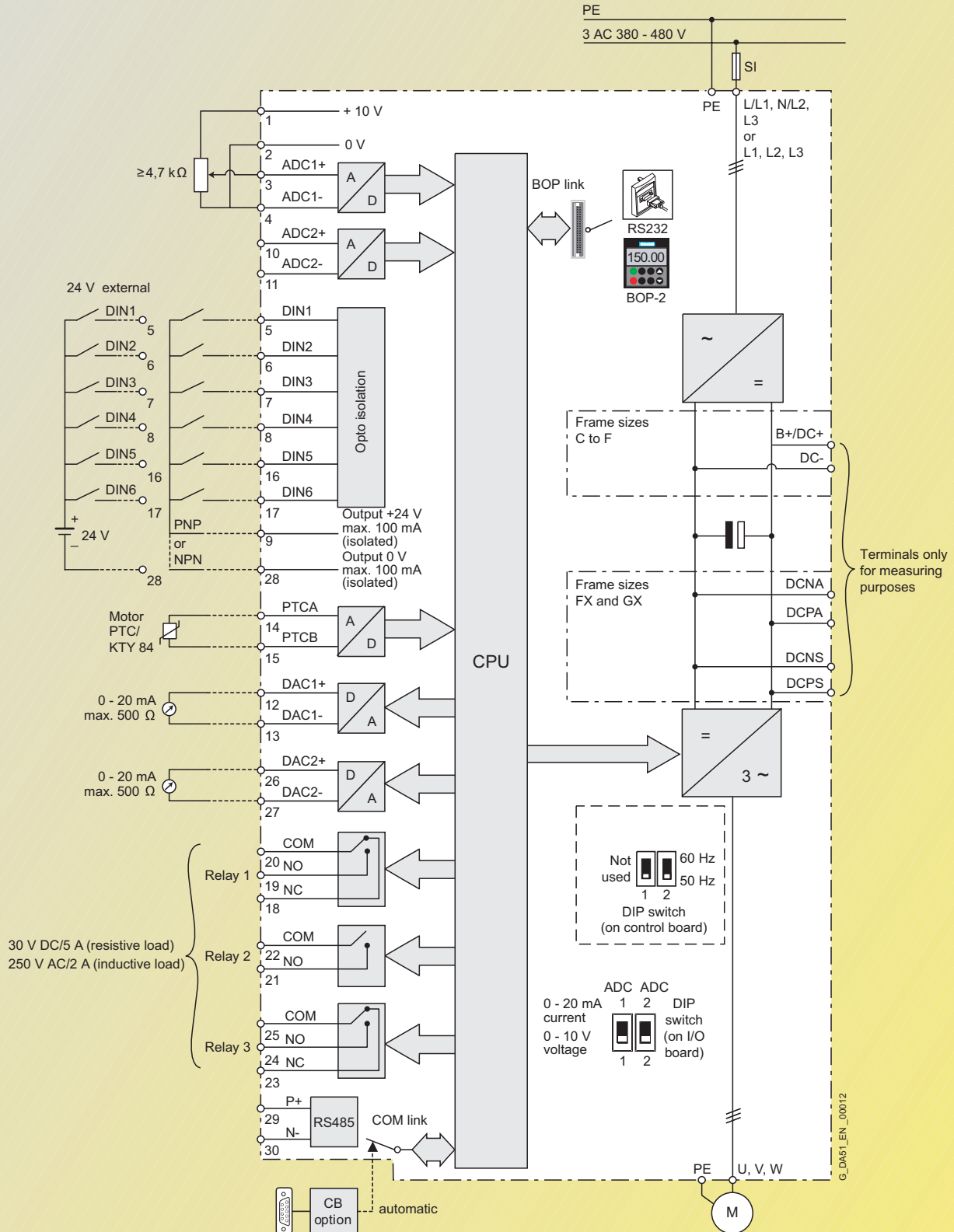

3

Terminal connection diagram

Example, frame size C





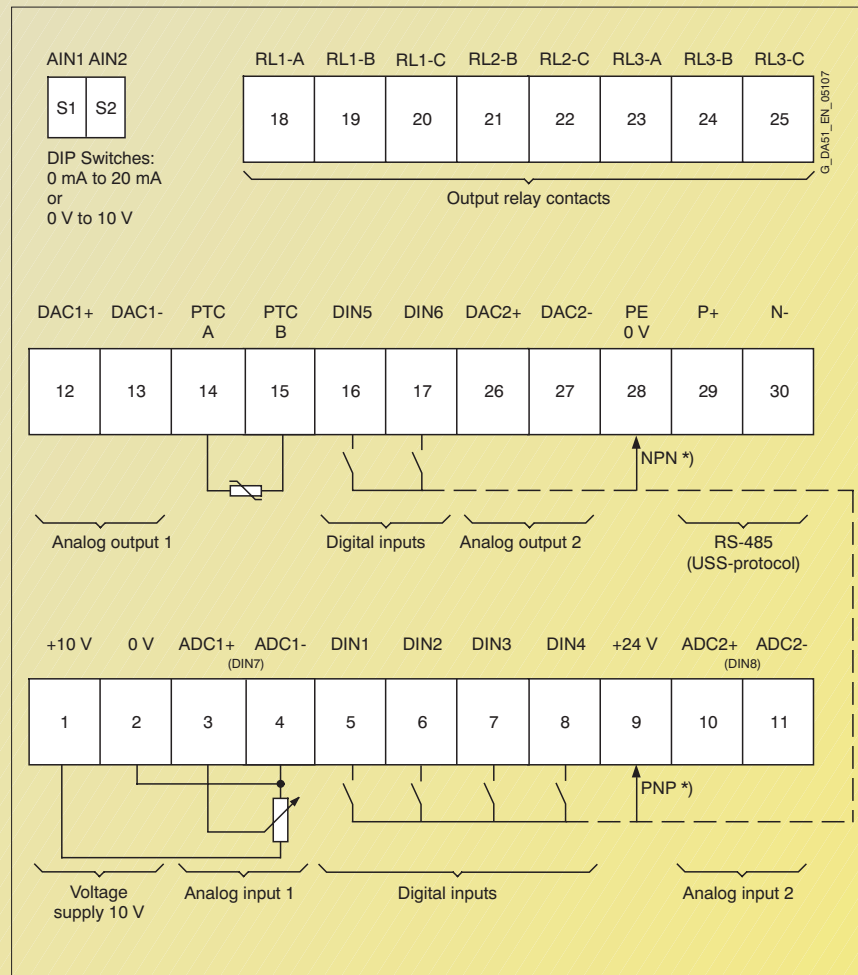





View A



*) PNP or NPN possible

Technical data

MICROMASTER 430 inverter

Mains voltage and Power ranges	3 AC 380 V to 480 V \pm 10 % 7.5 kW to 250 kW (variable torque)			
Power frequency	47 Hz to 63 Hz			
Output frequency	7.5 kW to 90 kW	0 Hz to 650 Hz		
	110 kW to 250 kW	0 Hz to 267 Hz		
Power factor	\geq 0.95			
Inverter efficiency	7.5 kW to 90 kW	96 % to 97 %		
	110 kW to 250 kW	97 % to 98 %		
Overload capability	7.5 kW to 90 kW	Overload current 1.4 x rated output current (i.e. +140 % overload capability) for 3 s, and 1.1 x rated output current (i.e. 110 % overload capability) for 60 s, cycle time 300 s		
	110 kW to 250 kW	Overload current 1.5 x rated output current (i.e. 150 % overload capability) for 1 s and 1.1 x rated output current (i.e. 110 % overload capability) for 60 s, cycle time 300 s		
Inrush current	Less than rated input current			
Control method	Linear V/f characteristic; quadratic V/f characteristic; multipoint characteristic (programmable V/f characteristic); flux current control (FCC), energy saving mode			
Pulse frequency	7.5 kW to 90 kW	4 kHz (standard)		
	110 kW to 250 kW	2 kHz to 16 kHz (in 2 kHz steps)		
		2 kHz (standard)		
		2 kHz to 4 kHz (in 2 kHz steps)		
Fixed frequencies	15, programmable			
Skip frequency ranges	4, programmable			
Setpoint resolution	0.01 Hz digital 0.01 Hz serial 10 bit analog			
Digital inputs	6 fully programmable isolated digital inputs; switchable PNP/NPN			
Analog inputs	2 programmable analog inputs			
	<ul style="list-style-type: none"> 0 V to 10 V, 0 mA to 20 mA and -10 V to +10 V (AIN1) 0 V to 10 V and 0 mA to 20 mA (AIN2) both can be used as 7th/8th digital input 			
Relay outputs	3, programmable, 30 V DC/5 A (resistive load); 250 V AC/2A (inductive load)			
Analog outputs	2, programmable (0/4 mA to 20 mA)			
Serial interfaces	RS-485, optional RS-232			
Motor cable length	7.5 kW to 90 kW	max. 50 m (shielded)		
	without output choke	max. 100 m (unshielded)		
	without output choke	see variant dependent options		
	110 kW to 250 kW	max. 100 m (shielded)		
	without output choke	max. 150 m (unshielded)		
	with output choke	see variant dependent options		
Electromagnetic compatibility	7.5 kW to 90 kW	Inverter with internal filter Class A available		
	For inverters without filter	EMC filter, Class B to EN 55 011 available as an option		
	7.5 kW to 15 kW	EMC filter, Class B from Schaffner available as an option		
	18.5 kW to 90 kW	EMC filter, Class A available as an option		
	110 kW to 250 kW	EMC filter, Class A available as an option		
Braking	DC braking, compound braking			
Degree of protection	IP20			
Operating temperature range	7.5 kW to 90 kW	-10 °C to +40 °C (+14 °F to +104 °F)		
	110 kW to 250 kW	0 °C to +40 °C (+32 °F to +104 °F)		
Storage temperature	-40 °C to +70 °C (-40 °F to +158 °F)			
Relative humidity	95 % (non-condensing)			
Installation altitude	7.5 kW to 90 kW	Up to 1000 m above sea level without derating		
	110 kW to 250 kW	Up to 2000 m above sea level without derating		
Protection features for	undervoltage, overvoltage, overload, earth faults, short-circuits, stall prevention, locked motor protection, motor overtemperature, inverter overtemperature, parameter change protection			
Conformity with standards	7.5 kW to 90 kW	   		
	110 kW to 250 kW	   available soon, 		
CE marking	Conformity with low-voltage directive 73/23/EEC			
Cooling-air volumetric flow required, dimensions and weights (without options)	Frame size (FS)	Cooling-air volumetric flow required (l/s)/(CFM)	H x W x D (mm)	Weight, approx. (kg)
	C	54.9/116.3	245 x 185 x 195	5.7
	D	2 x 54.9/2 x 116.3	520 x 275 x 245	17
	E	2 x 54.9/2 x 116.3	650 x 275 x 245	22
	F without filter	150/317.19	850 x 350 x 320	56
	F with filter	150/317.19	1150 x 350 x 320	75
	FX	225/478.13	1400 x 326 x 356	116
	GX	440/935	1533 x 326 x 545	176

CFM: Cubic Flow per Minute

Derating data

Pulse frequency

Output (for 3 AC 400 V) kW	Rated output current in A for a pulse frequency of							
	2 kHz	4 kHz	6 kHz	8 kHz	10 kHz	12 kHz	14 kHz	16 kHz
7.5	19.0	19.0	17.1	15.2	13.3	11.4	9.5	7.6
11.0	26.0	26.0	24.7	23.4	20.8	18.2	15.6	13.0
15.0	32.0	32.0	28.8	25.6	22.4	19.2	16.0	12.8
18.5	38.0	38.0	36.1	34.2	30.4	26.6	22.8	19.0
22	45.0	45.0	40.5	36.0	31.5	27.0	22.5	18.0
30	62.0	62.0	55.8	49.6	43.4	37.2	31.0	24.8
37	75.0	75.0	71.3	67.5	60.0	52.5	45.0	37.5
45	90.0	90.0	81.0	72.0	63.0	54.0	45.0	36.0
55	110.0	110.0	93.5	77.0	63.3	49.5	41.3	33.0
75	145.0	145.0	123.3	101.5	83.4	65.3	54.4	43.5
90	178.0	178.0	138.0	97.9	84.6	71.2	62.3	53.4
110	205.0	180.4	–	–	–	–	–	–
132	250.0	220.0	–	–	–	–	–	–
160	302.0	265.8	–	–	–	–	–	–
200	370.0	325.6	–	–	–	–	–	–
250	477.0	419.8	–	–	–	–	–	–

Operating temperature

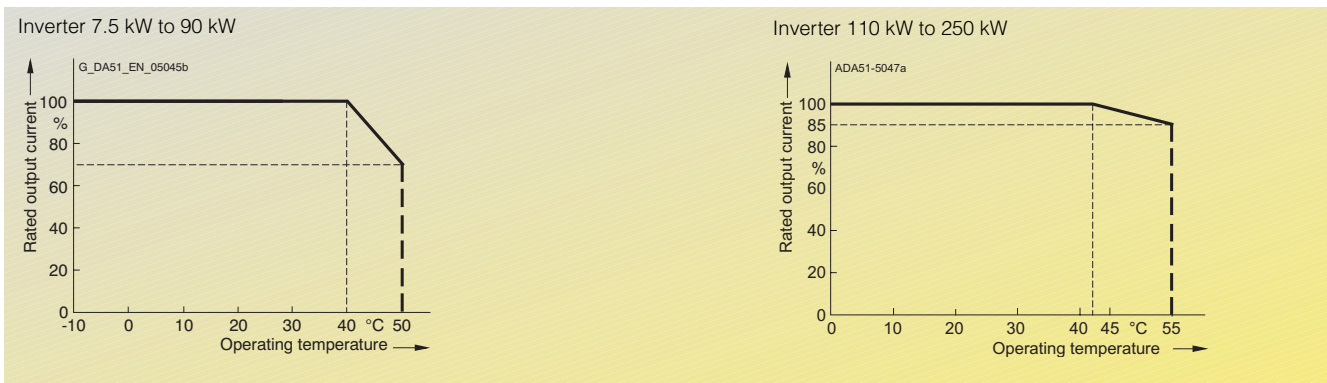

Technical data

Derating data (continued)

Installation height above sea level

Permissible output current
in % of the rated output current
Inverter 7.5 kW to 90 kW

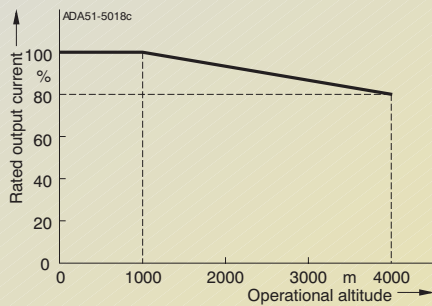

Inverter 110 kW to 250 kW

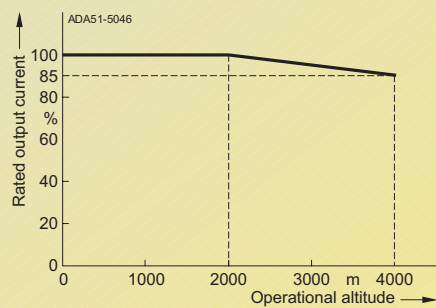

Permissible mains voltage
in % of the max. possible mains voltage
Inverter 7.5 kW to 90 kW

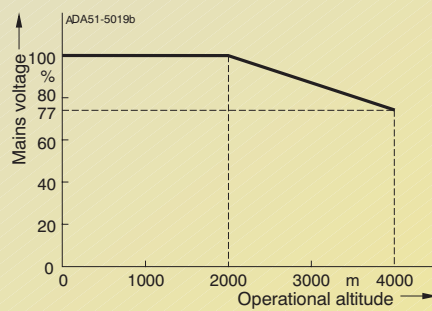

Inverter 110 kW to 250 kW

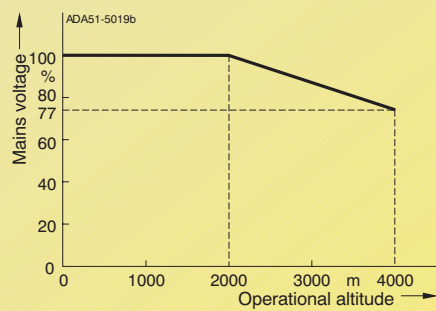

MICROMASTER 430 inverter

Output		Rated input current	Rated output current	Frame size	Order No.	
kW	hp	A	A	(FS)	MICROMASTER 430 without filter ⁴⁾	MICROMASTER 430 with internal filter Class A ³⁾
Mains operating voltage 3 AC 380 V to 480 V						
7.5	10	17.3 ¹⁾	19	C	6SE6430-2UD27-5CA0	6SE6430-2AD27-5CA0
11.0	15	23.1 ¹⁾	26	C	6SE6430-2UD31-1CA0	6SE6430-2AD31-1CA0
15.0	20	33.8 ¹⁾	32	C	6SE6430-2UD31-5CA0	6SE6430-2AD31-5CA0
18.5	25	37.0 ¹⁾	38	D	6SE6430-2UD31-8DA0	6SE6430-2AD31-8DA0
22	30	43.0 ¹⁾	45	D	6SE6430-2UD32-2DA0	6SE6430-2AD32-2DA0
30	40	59.0 ¹⁾	62	D	6SE6430-2UD33-0DA0	6SE6430-2AD33-0DA0
37	50	72.0 ¹⁾	75	E	6SE6430-2UD33-7EA0	6SE6430-2AD33-7EA0
45	60	87.0 ¹⁾	90	E	6SE6430-2UD34-5EA0	6SE6430-2AD34-5EA0
55	75	104.0 ¹⁾	110	F	6SE6430-2UD35-5FA0	6SE6430-2AD35-5FA0
75	100	139.0 ¹⁾	145	F	6SE6430-2UD37-5FA0	6SE6430-2AD37-5FA0
90	120	169.0 ¹⁾	178	F	6SE6430-2UD38-8FA0	6SE6430-2AD38-8FA0
110	150	200.0 ²⁾	205	FX	6SE6430-2UD41-1FA0	–
132	200	245.0 ²⁾	250	FX	6SE6430-2UD41-3FA0	–
160	250	297.0 ²⁾	302	GX	6SE6430-2UD41-6GA0	–
200	300	354.0 ²⁾	370	GX	6SE6430-2UD42-0GA0	–
250	350	442.0 ²⁾	477	GX	6SE6430-2UD42-5GA0	–



See Appendix for note on ordering.

All MICROMASTER 430 inverters are supplied with a Status Display Panel (SDP). A BOP-2 or other options have to be ordered separately (see Pages 3/14 to 3/16).

Motors for MICROMASTER 430

Catalog M 11 contains selection and ordering data for motors which are particularly suitable for operation with the MICROMASTER 430 inverters (see Appendix for overview).

This catalog is suitable for IEC motors. For motors according to US standards (NEMA) please refer to: <http://www.sea.siemens.com/motors>

1) Supplementary conditions: Input current at rated operating point, applicable at short-circuit voltage of the supply $U_{SC} = 2\%$ with reference to the inverter rated power and rated mains operating voltage of 400 V without a line commutating choke.

2) Supplementary conditions: Input current at rated operating point, applicable at short-circuit voltage of the supply $U_{SC} \geq 2.33\%$ with reference to the inverter rated power and rated mains voltage of 400 V.

3) Use of MICROMASTER inverters with internal filter is not permissible on non-grounded mains supplies.

4) Generally suited to heavy industrial applications. For details please refer to Appendix on page A/4.

Options Variant dependent options

Overview

EMC filter, Class A

All 7.5 kW to 90 kW inverters are supplied with an internal filter Class A.

For inverters 110 kW to 250 kW, EMC filters Class A are available. In this performance range, the EMC filters are only permitted to be used in combination with a line commutating choke.

The requirements are fulfilled using shielded cables with a max. length of 25 m.

EMC filter, Class B

Available for inverters 7.5 kW to 15 kW with an internal Class A EMC filter.

The requirements are fulfilled using shielded cables with a max. length of 25 m.

For inverters 18.5 kW to 90 kW without filters, EMC filters of Class B from Schaffner can be used.

The requirements are fulfilled using shielded cables with a max. length of 25 m to 50 m (depending on the type, details on request).

With this filter, the inverter complies with the emission standard EN 55 011, Class B.

Leakage currents:

The leakage currents of the inverters with/without filter (internal/external) may exceed 30 mA. Typical values in practice are between 10 mA and 50 mA. The exact values depend on the design, environment and cable lengths. Interference-free operation with residual current operated devices with a trigger value of 30 mA cannot be guaranteed.

However, operation with residual current operated devices with a trigger value of 300 mA is possible. Please refer to the Instruction Manual for details.

LC filter and sinusoidal filter

The LC filter/sinusoidal filter limits the rate of rise of voltage and the capacitive charge/discharge currents which usually occur with inverter operation. This means that much longer shielded motor cables are possible when using LC filters/sinusoidal filters and the service life of the motor achieves values similar to those with direct mains operation. Use of an output choke isn't required with that.

Please note when using LC filters/sinusoidal filters:

- Only V/f, FCC control permissible
- Please observe the derating of 15 % when selecting the appropriate inverter
- Operation only permissible with 4 kHz pulse frequency
Note: Please observe derating for frame sizes FX and GX.
- The output frequency is limited to 150 Hz.

The LC filters/sinusoidal filters can be used for all MICRO-MASTER 430 inverters of frame sizes C to GX.

- Frame sizes D to F:
The LC filters, frame sizes D to F, are designed for mounting upright in the control cabinet. Due to leakage flux lines caused by physical sources, a minimum distance of 50 mm to adjacent modules and metal parts is recommended.
- Frame sizes FX and GX:
The sinusoidal filters, frame sizes FX and GX, are designed for mounting upright in the control cabinet. Due to leakage flux lines caused by physical sources, a minimum distance of 100 mm to adjacent modules and metal parts is recommended.

Technical data

LC filter and sinusoidal filter

Mains voltage	3 AC 380 V to 480 V
Current (at 40 °C/50 °C)	
For frame size C (7.5 to 15 kW)	32.6 A/ 29.7 A
For frame size D (18.5 kW)	38.8 A/ 32 A
For frame size D (22 kW)	45.9 A/ 38 A
For frame size D (30 kW)	63.2 A/ 45 A
For frame size E (37 kW)	76.5 A/ 62 A
For frame size E (45 kW)	112.2 A/ 90 A
For frame size F (55 kW)	112.2 A/ 90 A
For frame size F (75 kW)	147.9 A/110 A
For frame size F (90 kW)	181.6 A/145 A
For frame size FX (110 kW and 132 kW)	225 A/191 A
For frame size GX (160 kW)	276 A/235 A
For frame size GX (200 kW)	333 A/283 A
For frame size GX (250 kW)	408 A/347 A
Limiting of motor overvoltage	≤ 1078 V
dV/dt limiting	≤ 500 V/μs
Pulse frequency	4 kHz
Max. motor frequency	150 Hz

Technical data (continued)

LC filter and sinusoidal filter

Max. permissible motor cable lengths				
For frame sizes C to F	shielded	200 m		
	unshielded	300 m		
For frame sizes FX and GX	shielded	300 m		
	unshielded	450 m		
Insulation strength		Overvoltage category III to VDE 0110		
Electromagnetic compatibility		Up to 200 m motor cable length with emissions to Class A according to EN 55 011 in conjunction with filtered inverters and unshielded cables		
For frame sizes C to F		Up to 150 m motor cable length with emissions to Class A according to EN 55 011 in conjunction with filtered inverters and unshielded cables		
For frame sizes FX and GX				
Conformity		CE according to the low-voltage directive 73/23/EEC		
Approvals		cUL E 219022		
Strain resistance		EN 60 068-2-31		
Humidity		95 % humidity, non-condensing		
Degree of protection		IP20 (to EN 60 529)		
For frame size C		IP00/IP20 (to EN 60 529 with terminal covers)		
For frame sizes D to F		IP00		
For frame sizes FX and GX				
Insulation class		H (180 °C)		
Temperature range				
For frame sizes C to F	Operation	-10 °C to +40 °C (+14 °F to +104 °F)		100 % P_n
	Storage	to +50 °C (to +122 °F)		80 % P_n
For frame sizes FX and GX	Operation	-25 °C to +70 °C (-13 °F to +158 °F)		
	Operation	-10 °C to +40 °C (+14 °F to +104 °F)		100 % P_n
		to +55 °C (to +131 °F)		80 % P_n
	Storage	-40 °C to +70 °C (-40 °F to +158 °F)		
Installation altitude				
For frame size C		Up to 2000 m:	100 % P_n	
		2000 to 4000 m:	62.5 % P_n	
For frame sizes D to F		Up to 1000 m:	100 % P_n	
		1000 to 4000 m:	12.5 % derating for each 1000 m	
For frame sizes FX and GX		Up to 2000 m:	100 % P_n	
		2000 to 4000 m:	7.5 % derating for each 1000 m	
Mounting position		Footprint or suspended upright		
For frame size C				
For frame sizes D to F, FX and GX				
Free space				
For frame sizes C	Top	100 mm		
	Bottom	100 mm		
	Side	100 mm		
For frame sizes D to F, FX and GX	Top	100 mm		
	Side	100 mm		
Connection system	Input, litz wire or terminal	1U1, 1V1, 1W1		
	Output, terminals	1U2, 1V2, 1W2		
Torque for conductor connections		Terminal cross-section	Torque	
For frame size C		-	1.5 Nm to 1.8 Nm	
For frame sizes D to F		16 mm ²	2.0 Nm to 4.0 Nm	
		35 mm ²	2.5 Nm to 5.0 Nm	
		50 mm ²	3.0 Nm to 6.0 Nm	
		95 mm ²	6.0 Nm to 12.0 Nm	
		150 mm ²	10.0 Nm to 20.0 Nm	
For frame sizes FX and GX		-	14.0 Nm to 31.0 Nm	
Weight, approx.				
For frame size C		8.5 kg to 29 kg		
For frame size D		21 kg to 34 kg		
For frame size E		49.5 kg to 67 kg		
For frame size F		67 kg to 77.5 kg		
For frame size FX		135 kg		
For frame size GX		138 kg to 208 kg		

Options Variant dependent options

Overview

Line commutating choke

Line commutating chokes are used to smooth voltage peaks or to bridge commutating dips.

In addition, line commutating chokes reduce the effects of harmonics on the inverter and the power supply. If the line impedance is $< 1\%$, a line commutating choke must be used in order to reduce the current peaks.

No limits are currently defined in the EN 61 000-3-2 standard for professionally used devices with a connected load > 1 kW.

This means that the inverters with an output power ≥ 0.75 kW comply with the EN 61 000-3-2 standard.

Output choke

Output chokes can be supplied for reducing the capacitive compensation currents and dV/dt in the case of motor cables > 50 m (shielded) or > 100 m (unshielded).

For max. permissible cable lengths, see Technical Data.

Gland plate

Gland plates are available for inverters of frame size C. In frame sizes D, E and F, the gland plates are integrated.

The gland plate facilitates the shield connection of power and control cables and thus ensures optimum EMC performance.

Technical data

Max. permissible cable lengths from the motor to the inverter when using output chokes

The following table shows the maximum permissible cable lengths from the motor to the inverter when using output chokes.

Note:

Operation up to 150 Hz output frequency only!

Frame size (FS)	Output choke Type	Max. permissible motor cable lengths (shielded/unshielded) for a mains voltage of	
		380 V to 400 V $\pm 10\%$	401 V to 480 V $\pm 10\%$
C	6SE6400-3TC03-2CD3	200 m/300 m	100 m/150 m
D to F	6SE6400-3TC D0	200 m/300 m	200 m/300 m
FX	6SL3000-2BE32-1AA0	300 m/450 m	300 m/450 m
FX	6SL3000-2BE32-6AA0	300 m/450 m	300 m/450 m
GX	6SL3000-2BE33-2AA0	300 m/450 m	300 m/450 m
GX	6SL3000-2BE33-8AA0	300 m/450 m	300 m/450 m
GX	6SL3000-2BE35-0AA0	300 m/450 m	300 m/450 m

Design

General installation instructions

- A maximum of two footprint components plus inverter are permissible.
- If an LC filter is used, it must be mounted directly on the wall of the control cabinet due to weight reasons. If an LC filter of frame size C is used, therefore, only one footprint component is permissible. If a line choke and LC filter are used, the line choke must be located on the left of the inverter. Required spacing: 75 mm.
- The EMC filter must be mounted directly below the frequency inverter if possible.
- If mounted on the side, the line-side components are to be mounted to the left of the frequency inverter whereas the output-side components are to be mounted to the right of the frequency inverter.

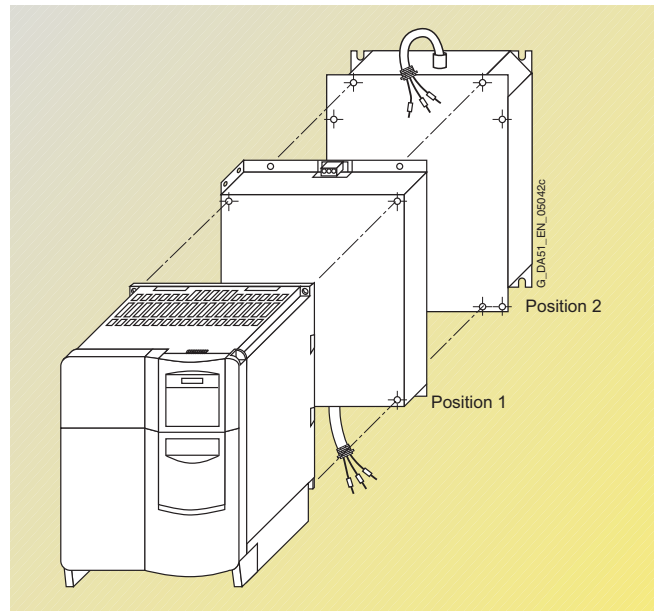

Example of installation with frequency inverter, EMC filter (position 1) and line choke (position 2)

Availability of the options as footprint components

	Frame size							
	C	D	E	F	G	FX	GX	
Line commutating choke	✓	✓	✓					
EMC filter	✓							
LC filter	✓							
Output choke	✓							

Recommended combinations of inverters and options



Frequency inverter Frame size	Footprint		Mounted on side	
	Position 1	Position 2	To the left of the inverter (for line-side components)	To the right of the inverter (for output-side components)
C	EMC filter	Line commutating choke	–	Output choke
	EMC filter <u>or</u> Line commutating choke	Output choke	–	–
	LC filter	–	EMC filter <u>and/or</u> Line commutating choke	–
D and E	Line commutating choke	–	EMC filter	Output choke <u>or</u> LC filter
F, G, FX and GX	–	–	EMC filter <u>and/or</u> Line commutating choke	Output choke <u>or</u> LC filter

Options Variant dependent options

Selection and ordering data

The options listed here (filters, chokes, gland plates, fuses and circuit-breakers) must be selected to match the inverter.

The inverter and the associated options have the same voltage ratings.

All options are certified to , except fuses. The 3NE1 fuses are -listed (equivalent to ).

● Use in America requires -listed fuses such as the Class NON range from Bussmann.

Mains voltage	Output		Inverter without filter	Order No. of the options		
	kW	hp		EMC filter, Class A	EMC filter, Class B	Line commutating choke
3 AC 380 V to 480 V	7.5	10	6SE6430-2UD27-5CA0	–	–	6SE6400-3CC02-2CD3
	11.0	15	6SE6430-2UD31-1CA0	–	–	–
	15.0	20	6SE6430-2UD31-5CA0	–	–	6SE6400-3CC03-5CD3
	18.5	25	6SE6430-2UD31-8DA0	–	EMC filter, Class B, available from Schaffner	6SE6400-3CC04-4DD0
	22	30	6SE6430-2UD32-2DA0	–	–	–
	30	40	6SE6430-2UD33-0DA0	–	–	6SE6400-3CC05-2DD0
	37	50	6SE6430-2UD33-7EA0	–	–	6SE6400-3CC08-3ED0
	45	60	6SE6430-2UD34-5EA0	–	–	–
	55	75	6SE6430-2UD35-5FA0	–	–	6SE6400-3CC11-2FD0
	75	100	6SE6430-2UD37-5FA0	–	–	–
	90	120	6SE6430-2UD38-8FA0	–	–	6SE6400-3CC11-7FD0
	110	150	6SE6430-2UD41-1FA0	6SL3000-0BE32-5AA0 *)	–	6SL3000-0CE32-3AA0
	132	200	6SE6430-2UD41-3FA0	6SL3000-0BE34-4AA0 *)	–	6SL3000-0CE32-8AA0
	160	250	6SE6430-2UD41-6GA0	–	–	6SL3000-0CE33-3AA0
	200	300	6SE6430-2UD42-0GA0	–	–	6SL3000-0CE35-1AA0
250	350	6SE6430-2UD42-5GA0	6SL3000-0BE36-0AA0 *)	–	–	

*) Must be used in combination with a line commutating choke.

Mains voltage	Output		Inverter without filter	Order No. of the options		
	kW	hp		LC/sinusoidal filter	Output choke	Gland plate
3 AC 380 V to 480 V	7.5	10	6SE6430-2UD27-5CA0	6SE6400-3TD03-2CD0	6SE6400-3TC03-2CD3	6SE6400-0GP00-0CA0
	11.0	15	6SE6430-2UD31-1CA0	–	–	–
	15.0	20	6SE6430-2UD31-5CA0	–	–	–
	18.5	25	6SE6430-2UD31-8DA0	6SE6400-3TD03-7DD0	6SE6400-3TC05-4DD0	Integrated as standard
	22	30	6SE6430-2UD32-2DA0	6SE6400-3TD04-8DD0	6SE6400-3TC03-8DD0	–
	30	40	6SE6430-2UD33-0DA0	6SE6400-3TD06-1DD0	6SE6400-3TC05-4DD0	–
	37	50	6SE6430-2UD33-7EA0	6SE6400-3TD07-2ED0	6SE6400-3TC08-0ED0	–
	45	60	6SE6430-2UD34-5EA0	6SE6400-3TD11-5FD0	6SE6400-3TC07-5ED0	–
	55	75	6SE6430-2UD35-5FA0	–	6SE6400-3TC14-5FD0	–
	75	100	6SE6430-2UD37-5FA0	6SE6400-3TD15-0FD0	6SE6400-3TC15-4FD0	–
	90	120	6SE6430-2UD38-8FA0	6SE6400-3TD18-0FD0	6SE6400-3TC14-5FD0	–
	110	150	6SE6430-2UD41-1FA0	6SL3000-2CE32-3AA0	6SL3000-2BE32-1AA0	–
	132	200	6SE6430-2UD41-3FA0	–	6SL3000-2BE32-6AA0	–
	160	250	6SE6430-2UD41-6GA0	6SL3000-2CE32-8AA0	6SL3000-2BE33-2AA0	–
	200	300	6SE6430-2UD42-0GA0	6SL3000-2CE33-3AA0	6SL3000-2BE33-8AA0	–
250	350	6SE6430-2UD42-5GA0	6SL3000-2CE34-1AA0	6SL3000-2BE35-0AA0	–	

Mains voltage	Output		Inverter without filter	Order No. of the options		Circuit-breaker (see Catalog LV 10)
	kW	hp		Fuses (see Catalog LV 10) 3NA3	3NE1 	
3 AC 380 V to 480 V	7.5	10	6SE6430-2UD27-5CA0	3NA3807	●	3RV1031-4EA10
	11.0	15	6SE6430-2UD31-1CA0	3NA3812	–	3RV1031-4FA10
	15.0	20	6SE6430-2UD31-5CA0	3NA3814	–	3RV1031-4HA10
	18.5	25	6SE6430-2UD31-8DA0	3NA3820	3NE1817-0	3RV1042-4KA10
	22	30	6SE6430-2UD32-2DA0	3NA3822	3NE1818-0	–
	30	40	6SE6430-2UD33-0DA0	3NA3824	3NE1820-0	3RV1042-4MA10
	37	50	6SE6430-2UD33-7EA0	3NA3830	3NE1021-0	3VL1712-.DD33-....
	45	60	6SE6430-2UD34-5EA0	3NA3832	3NE1022-0	3VL1716-.DD33-....
	55	75	6SE6430-2UD35-5FA0	3NA3836	3NE1224-0	3VL3720-.DC36-....
	75	100	6SE6430-2UD37-5FA0	3NA3140	3NE1225-0	3VL3725-.DC36-....
	90	120	6SE6430-2UD38-8FA0	3NA3144	3NE1227-0	3VL4731-.DC36-....
	110	150	6SE6430-2UD41-1FA0	–	–	3VL3725-.DC36-....
	132	200	6SE6430-2UD41-3FA0	–	3NE1230-0	3VL4731-.DC36-....
	160	250	6SE6430-2UD41-6GA0	–	3NE1332-0	–
	200	300	6SE6430-2UD42-0GA0	–	3NE1333-0	3VL4740-.DC36-....
250	350	6SE6430-2UD42-5GA0	–	3NE1435-0	3VL5750-.DC36-....	

Selection and ordering data (continued)

Mains voltage	Output		Inverter with internal filter Class A	Order No. of the options		
	kW	hp		Additional EMC filter, Class B	Line commutating choke	LC filter
3 AC 380 V to 480 V	7.5	10	6SE6430-2AD27-5CA0	6SE6400-2FS03-8CD0	6SE6400-3CC02-2CD3	6SE6400-3TD03-2CD0
	11.0	15	6SE6430-2AD31-1CA0			
	15.0	20	6SE6430-2AD31-5CA0		6SE6400-3CC03-5CD3	
	18.5	25	6SE6430-2AD31-8DA0	An inverter without filter must be selected to satisfy the EMC requirements of Class B. In addition, an appropriate EMC filter of Class B is from Schaffner is required.	6SE6400-3CC04-4DD0	6SE6400-3TD03-7DD0
	22	30	6SE6430-2AD32-2DA0		6SE6400-3CC05-2DD0	6SE6400-3TD04-8DD0
	30	40	6SE6430-2AD33-0DA0		6SE6400-3CC05-2DD0	6SE6400-3TD06-1DD0
	37	50	6SE6430-2AD33-7EA0		6SE6400-3CC08-3ED0	6SE6400-3TD07-2ED0
	45	60	6SE6430-2AD34-5EA0		6SE6400-3CC11-2FD0	6SE6400-3TD11-5FD0
	55	75	6SE6430-2AD35-5FA0			
	75	100	6SE6430-2AD37-5FA0			6SE6400-3TD15-0FD0
90	120	6SE6430-2AD38-8FA0	6SE6400-3CC11-7FD0		6SE6400-3TD18-0FD0	

Mains voltage	Output		Inverter with internal filter Class A	Order No. of the options	
	kW	hp		Output choke	Gland plate
3 AC 380 V to 480 V	7.5	10	6SE6430-2AD27-5CA0	6SE6400-3TC03-2CD3	6SE6400-0GP00-0CA0
	11.0	15	6SE6430-2AD31-1CA0		
	15.0	20	6SE6430-2AD31-5CA0		
	18.5	25	6SE6430-2AD31-8DA0	6SE6400-3TC05-4DD0	Integrated as standard
	22	30	6SE6430-2AD32-2DA0	6SE6400-3TC03-8DD0	
	30	40	6SE6430-2AD33-0DA0	6SE6400-3TC05-4DD0	
	37	50	6SE6430-2AD33-7EA0	6SE6400-3TC08-0ED0	
	45	60	6SE6430-2AD34-5EA0	6SE6400-3TC07-5ED0	
	55	75	6SE6430-2AD35-5FA0	6SE6400-3TC14-5FD0	
	75	100	6SE6430-2AD37-5FA0	6SE6400-3TC15-4FD0	
90	120	6SE6430-2AD38-8FA0	6SE6400-3TC14-5FD0		

Mains voltage	Output		Inverter with internal filter Class A	Order No. of the options		Circuit-breaker (see Catalog LV 10)
	kW	hp		Fuses (see Catalog LV 10)	3NE1 (A)	
3 AC 380 V to 480 V	7.5	10	6SE6430-2AD27-5CA0	3NA3807	●	3RV1031-4EA10
	11.0	15	6SE6430-2AD31-1CA0	3NA3812		3RV1031-4FA10
	15.0	20	6SE6430-2AD31-5CA0	3NA3814		3RV1031-4HA10
	18.5	25	6SE6430-2AD31-8DA0	3NA3820	3NE1817-0	3RV1042-4KA10
	22	30	6SE6430-2AD32-2DA0	3NA3822	3NE1818-0	
	30	40	6SE6430-2AD33-0DA0	3NA3824	3NE1820-0	3RV1042-4MA10
	37	50	6SE6430-2AD33-7EA0	3NA3830	3NE1021-0	3VL1712-.DD33-....
	45	60	6SE6430-2AD34-5EA0	3NA3832	3NE1022-0	3VL1716-.DD33-....
	55	75	6SE6430-2AD35-5FA0	3NA3836	3NE1224-0	3VL3720-.DC36-....
	75	100	6SE6430-2AD37-5FA0	3NA3140	3NE1225-0	3VL3725-.DC36-....
90	120	6SE6430-2AD38-8FA0	3NA3144	3NE1227-0	3VL4731-.DC36-....	

● Use in America requires Ⓜ-listed fuses such as the Class NON range from Bussmann.

Options

Variant independent options

Overview

Basic Operator Panel 2 (BOP-2)

With the BOP-2, individual parameter settings can be made. Values and units are shown on a 5-digit display.



Basic Operator Panel (BOP-2)

A BOP-2 can be used for several inverters. It can be directly mounted on the inverter or in a control cabinet door using a mounting kit.

PROFIBUS module

For a complete PROFIBUS connection with up to ≤ 12 Mbaud. Remote control of the inverter is possible with the PROFIBUS module. Remote control and operation at the inverter can be combined using an operator panel plugged onto the PROFIBUS module. The PROFIBUS module can be supplied by an external 24 V DC power supply and is thus also active when the inverter is disconnected from the power supply.

Connection by means of a 9-pin Sub-D connector (available as an option).

DeviceNet module

For networking the inverters to the DeviceNet fieldbus system widely used on the American market. A maximum transmission rate of 500 kbaud is possible. Remote control of the inverter is possible with the DeviceNet module.

Remote control and operation at the inverter can be combined using an operator panel plugged onto the DeviceNet module.

The connection to the DeviceNet bus system is made using a 5-pin connector with terminal strip.

CANopen module

Using the CANopen communications module, an inverter can be linked to the CANopen fieldbus system and remote control is then possible.

Remote control and operation at the inverter can be combined using an operator panel plugged onto the CANopen module.

The module is connected to the bus system through a 9-pin Sub-D connector.

Connection kit for PC to inverter

For controlling an inverter directly from a PC if the appropriate software has been installed (e.g. STARTER). Isolated RS-232 adapter module for reliable point-to-point connection to a PC. Includes a Sub-D connector and an RS-232 standard cable (3 m).

Operator panel door mounting kit for single inverter

For mounting an operator panel BOP-2 in a control cabinet door. Degree of protection IP56. Contains a cable adapter module with screwless terminals for use with user's own RS-232 cables ¹⁾.

Start-up tools

- **STARTER** is a graphic start-up software for guided start-up for MICROMASTER 410/420/430/440 frequency inverters under Windows NT/2000/XP Professional. Parameter lists can be read out, altered, stored, entered and printed.
- **DriveMonitor** is a start-up software for list-oriented programming of frequency inverters. This program executes under Windows 98/NT/2000/ME/XP Professional.

Both programs are included on the Docu CD which is provided with every inverter.

¹⁾ A shielded cable of type Belden 8132 (28 AWG) is recommended. The maximum cable length is 5 m for RS-232.

Selection and ordering data

The options listed here are suitable for all MICROMASTER 430 inverters.

Options	Order No.
Basic Operator Panel 2 (BOP-2)	6SE6400-0BE00-0AA0
PROFIBUS module	6SE6400-1PB00-0AA0
DeviceNet module	6SE6400-1DN00-0AA0
CANopen module	6SE6400-1CB00-0AA0
RS485/PROFIBUS bus connector	6GK1500-0FC00
Connection kit for PC to inverter	6SE6400-1PC00-0AA0
Operator panel door mounting kit for single inverter	6SE6400-0PM00-0AA0
Start-up tool STARTER on CD-ROM	6SL3072-0AA00-0AG0

Available on the Internet at:
<http://www4.ad.siemens.de/WWW/view/com/10804985/133100>

Technical data of the communication modules

PROFIBUS module
6SE6400-1PB00-0AA0



DeviceNet module
6SE6400-1DN00-0AA0



Size (height x width x depth)	161 mm x 73 mm x 46 mm	
Degree of protection	IP20	
Degree of pollution	2 to IEC 60664-1 (DIN VDE 0110/T1), no condensation permitted during operation	
Strain resistance	to IEC 60068-2-6 (if module is installed correctly)	
• Stationary	Deflection	0.15 mm in the frequency range of 10 Hz to 58 Hz
	Acceleration	19.6 m/s ² in the frequency range of 58 Hz to 500 Hz
• Transport	Deflection	3.5 mm in the frequency range of 5 Hz to 9 Hz
	Acceleration	9.8 m/s ² in the frequency range of 9 Hz to 500 Hz
Climatic category (during operation)	3K3 to IEC 60721-3-3	
Cooling method	Natural air cooling	
Permissible ambient or cooling agent temperature		
• Operation	-10 °C to +50 °C (+14 °F to +122 °F)	
• Storage and transport	-25 °C to +70 °C (-13 °F to +158 °F)	
Relative humidity (permissible humidity rating)		
• Operation	≤ 85 % (non-condensing)	
• Storage and transport	≤ 95 %	
Electromagnetic compatibility	Emission Interference	to EN 55011 (1991) Class A to IEC 60801-3 and EN 61000-4-3
Power supply	6.5 V ± 5 %, max. 300 mA, internal from inverter or 24 V ± 10 %, max. 350 mA, external	6.5 V ± 5 %, max. 300 mA internal from inverter or 24 V, max. 60 mA from DeviceNet-Bus
Output voltage	5 V ± 10 %, max. 100 mA, galvanically isolated supply • for terminating the serial interface bus or • for supplying the OLP (Optical Link Plug)	-
Data transmission rate	max. 12 Mbaud	125, 250 and 500 Kbaud

Options Variant independent options

Technical data of the communication modules (continued)

CANopen module
6SE6400-1CB00-0AA0



Size (height x width x depth)	161 mm x 73 mm x 46 mm
Degree of protection	IP20
Degree of pollution	2 to IEC 60664-1 (DIN VDE 0110/T1), no condensation permitted during operation
Strain resistance	to IEC 60068-2-6 (if module is installed correctly)
• Stationary	Deflection Acceleration 0.15 mm in the frequency range of 10 Hz to 58 Hz 19.6 m/s ² in the frequency range of 58 Hz to 500 Hz
• Transport	Deflection Acceleration 3.5 mm in the frequency range of 5 Hz to 9 Hz 9.8 m/s ² in the frequency range of 9 Hz to 500 Hz
Climatic category (during operation)	3K3 to IEC 60721-3-3
Cooling method	Natural air cooling
Permissible ambient or cooling agent temperature	
• Operation	-10 °C to +50 °C (+14 °F to +122 °F)
• Storage	-40 °C to +70 °C (-40 °F to +158 °F)
• Transport	-25 °C to +70 °C (-13 °F to +158 °F)
Relative humidity (permissible humidity rating)	
• Operation	≤ 85 % (non-condensing)
• Storage and transport	≤ 95 %
Power supply	The CAN bus is supplied from the inverter power supply
Data transmission rate	10, 20, 50, 125, 250, 500, 800 Kbaud and 1 Mbaud

Documentation

Selection and ordering data

Type of documentation	Language	Order No.
Docu pack , supplied with each inverter, containing CD-ROM ¹⁾ and Getting Started Guide ²⁾ (paper version)	Multilanguage	6SE6400-5AD00-1AP1
Operating instructions²⁾ (paper version)	German	6SE6400-5AE00-0AP0
	English	6SE6400-5AE00-0BP0
	French	6SE6400-5AE00-0DP0
	Italian	6SE6400-5AE00-0CP0
	Spanish	6SE6400-5AE00-0EP0
Parameter list²⁾ (paper version)	German	6SE6400-5AF00-0AP0
	English	6SE6400-5AF00-0BP0
	French	6SE6400-5AF00-0DP0
	Italian	6SE6400-5AF00-0CP0
	Spanish	6SE6400-5AF00-0EP0

1) The CD-ROM contains operating instructions, parameter list, commissioning tools STARTER and DriveMonitor, multilanguage.

Available on the Internet:
DriveMonitor at
<http://www4.ad.siemens.de/WW/view/com/10804984/133100>

STARTER at
<http://www4.ad.siemens.de/WW/view/com/10804985/133100>

2) Available on the Internet at
<http://www.siemens.com/micromaster>

MICROMASTER 430 inverter

Frame size	3 AC 380 V to 480 V
C	7.5 kW to 15 kW
D	18.5 kW to 30 kW
E	37 kW to 45 kW

Note:
The inverters must not be mounted horizontally.
But the inverters can be mounted without lateral spacing.

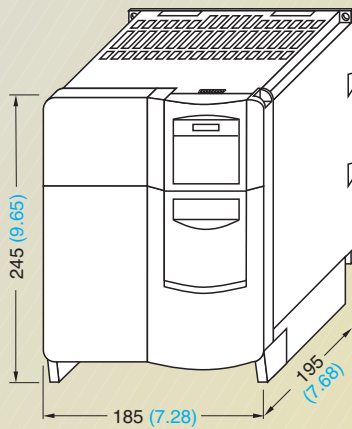

Inverter frame size C

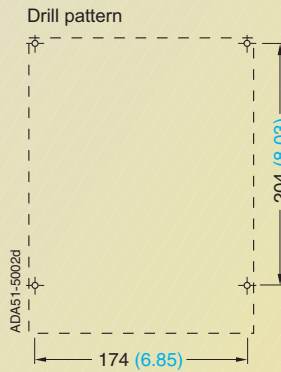

Fixing with
4 x M5 bolts
4 x M5 nuts
4 x M5 washers
Tightening torque with washers fitted:
3.0 Nm
Ventilation clearance required at top
and bottom: 100 mm

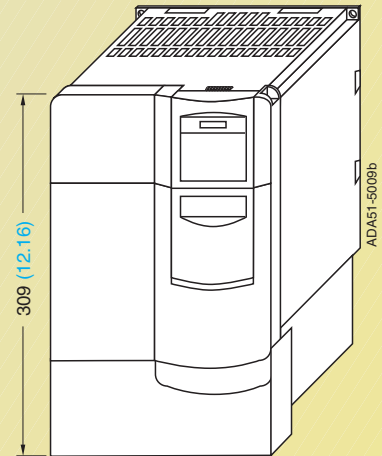

**Inverter frame size C
with gland plate**

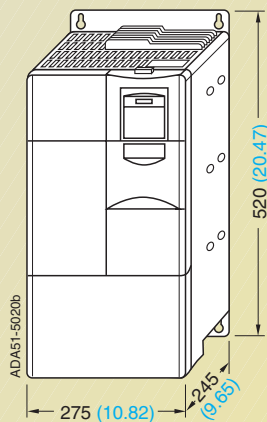

Inverter frame size D



Fixing with
4 x M8 bolts
4 x M8 nuts
4 x M8 washers
Tightening torque with
washers fitted: 3.0 Nm
Ventilation clearance
required at top and bottom:
300 mm

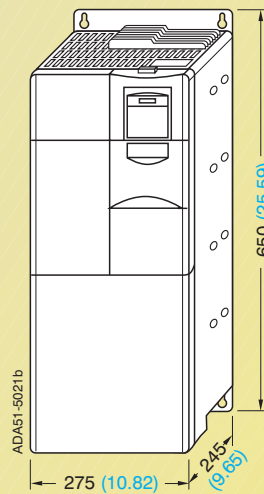

Inverter frame size E

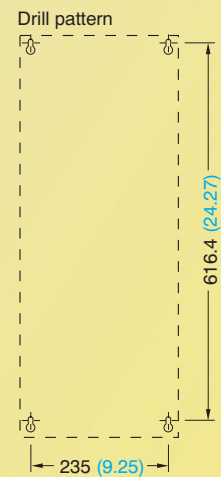

Fixing with
4 x M8 bolts
4 x M8 nuts
4 x M8 washers
Tightening torque with
washers fitted: 3.0 Nm
Ventilation clearance
required at top and bottom:
300 mm

With the communication module, the mounting depth increases for frame size C by 23 mm (0.91 inches).

All dimensions in mm (values in brackets are in inches)

MICROMASTER 430

Dimension drawings

MICROMASTER 430 inverter

Frame size	3 AC 380 V to 480 V
F	55 kW to 90 kW

Note:
The inverters must not be mounted horizontally.
But the inverters can be mounted without lateral spacing.

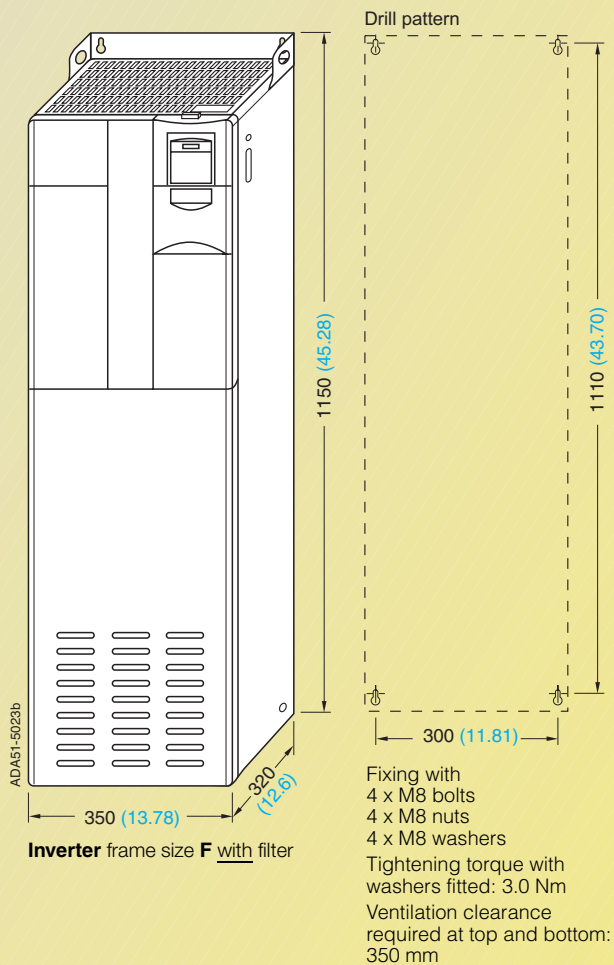
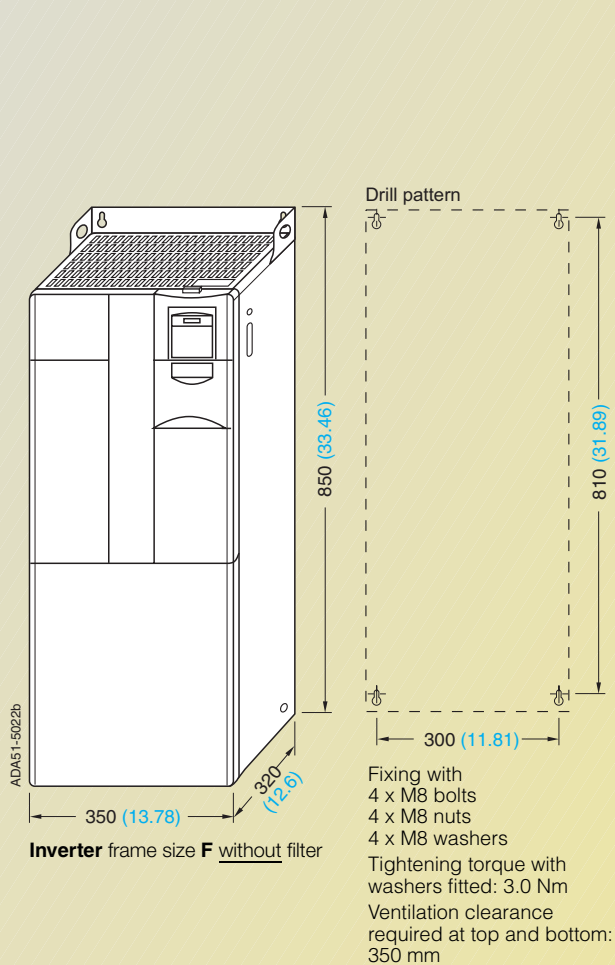

All dimensions in mm (values in brackets are in inches)

MICROMASTER 430 inverter

Frame size	3 AC 380 V to 480 V
FX	110 kW to 132 kW
GX	160 kW to 250 kW

Note:
The inverters must not be mounted horizontally.
But the inverters can be mounted without lateral spacing.

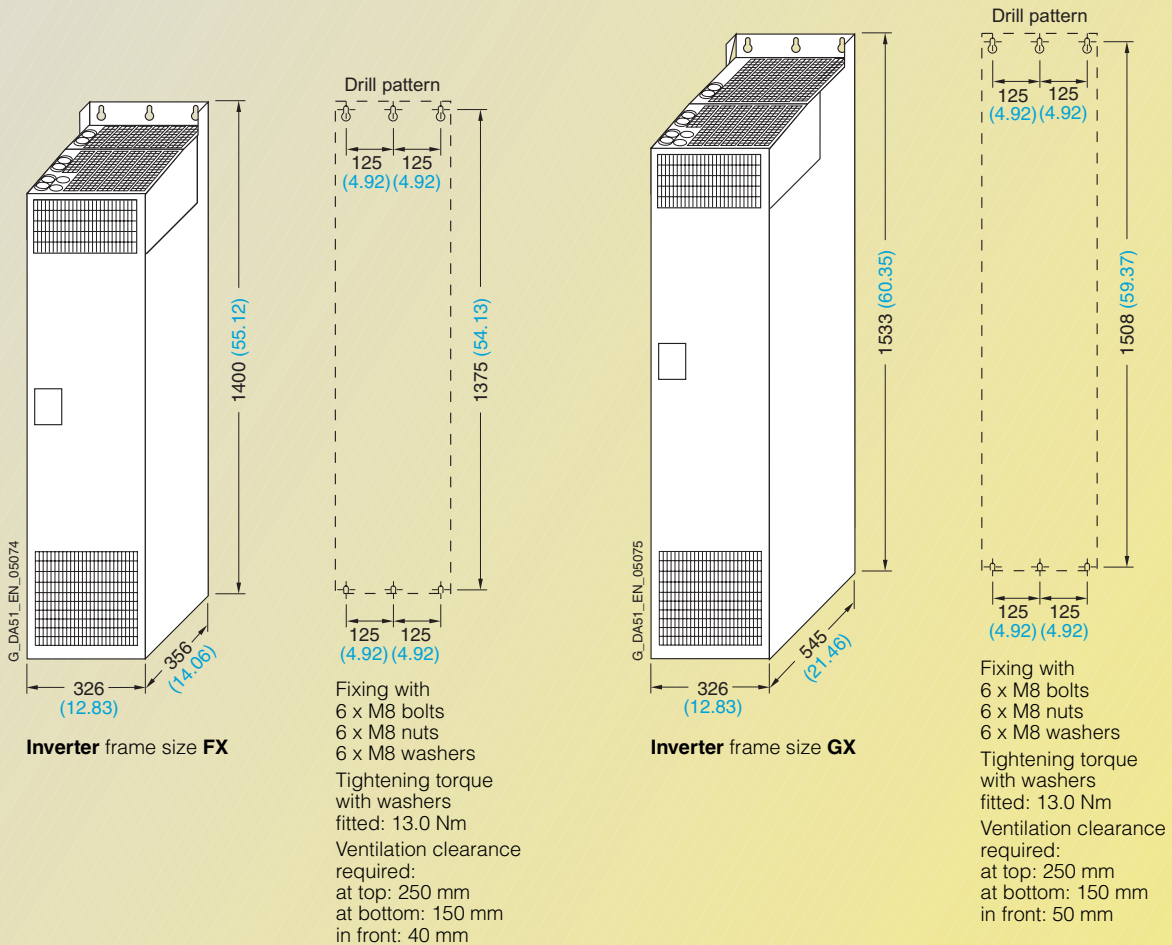

All dimensions in mm (values in brackets are in inches)

Dimension drawings

EMC filter

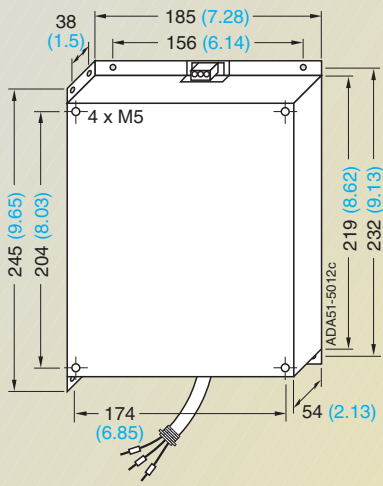

EMC filter for frame size **C**

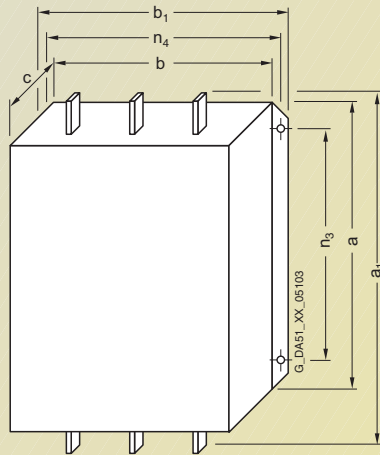

EMC filter Class A Type 6SL3000-	for inverter Frame size (FS)	Dimensions							Weight, approx. kg
		a	a ₁	b	b ₁	c	n ₃	n ₄	
OBE32-5AA0	FX	270 (10.63)	360 (14.17)	200 (7.87)	240 (9.45)	116 (4.57)	210 (8.27)	220 (8.66)	12.3
OBE34-4AA0	FX/GX	270 (10.63)	360 (14.17)	200 (7.87)	240 (9.45)	116 (4.57)	210 (8.27)	220 (8.66)	12.3
OBE36-0AA0	GX	310 (12.2)	400 (15.75)	215 (8.46)	265 (10.43)	140 (5.51)	250 (9.84)	240 (9.45)	19.0

EMC filter for frame sizes **FX** and **GX**

All dimensions in mm (values in brackets are in inches)

LC filter

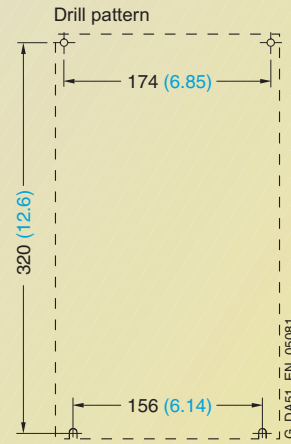
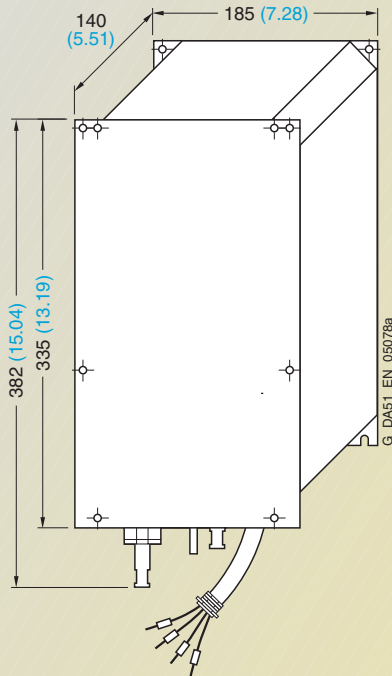

Fixing with M5 bolts

LC filter 6SE6400-3TD03-2CD0 for frame size **C**

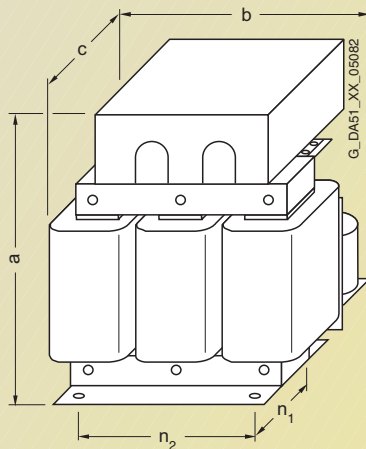

Fixing with M10 bolts

LC filter for frame sizes **D to F**

LC filter Type	for inverter Frame size (FS)	Dimensions				
		a	b	c	n ₁	n ₂
6SE6400-3TD03-7DD0	D	278 (10.94)	240 (9.45)	230 (9.06)	115 (4.53)	190 (7.48)
6SE6400-3TD04-8DD0	D	290 (11.42)	240 (9.45)	240 (9.45)	125 (4.92)	190 (7.48)
6SE6400-3TD06-1DD0	D	345 (13.58)	300 (11.81)	220 (8.66)	120 (4.72)	240 (9.45)
6SE6400-3TD07-2ED0	E	355 (13.98)	300 (11.81)	235 (9.25)	145 (5.71)	240 (9.45)
6SE6400-3TD11-5FD0	E/F	460 (18.11)	360 (14.17)	235 (9.25)	125 (4.92)	264 (10.39)
6SE6400-3TD15-0FD0	F	460 (18.11)	360 (14.17)	250 (9.84)	140 (5.51)	264 (10.39)
6SE6400-3TD18-0FD0	F	520 (20.47)	420 (16.54)	290 (11.42)	173 (6.81)	316 (12.44)

All dimensions in mm (values in brackets are in inches)

Dimension drawings

Sinusoidal filter

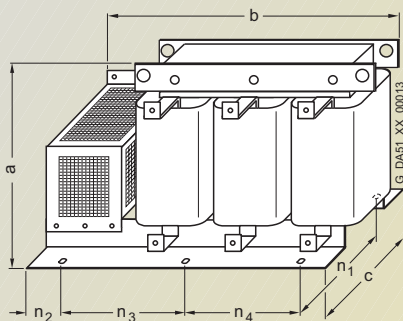

Sinusoidal filter for frame sizes **FX** and **GX**

Sinusoidal filter Type 6SL3000-	for inverter Frame size (FS)	Dimensions							Weight (max.) kg
		a	b	c	n ₁	n ₂	n ₃	n ₄	
2CE32-3AA0	FX	300 (11.81)	620 (24.41)	320 (12.6)	280 (11.02)	105 (4.13)	225 (8.86)	150 (5.91)	135.0
2CE32-8AA0	GX	300 (11.81)	620 (24.41)	320 (12.6)	280 (11.02)	105 (4.13)	225 (8.86)	150 (5.91)	138.0

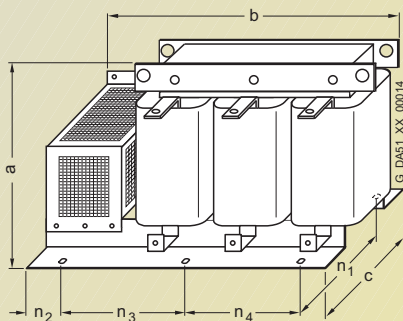

Sinusoidal filter for frame size **GX**

Sinusoidal filter Type 6SL3000-	for inverter Frame size (FS)	Dimensions							Weight (max.) kg
		a	b	c	n ₁	n ₂	n ₃	n ₄	
2CE33-3AA0	GX	370 (14.57)	620 (24.41)	360 (14.17)	320 (12.6)	105 (4.13)	225 (8.86)	150 (5.91)	144.0
2CE34-1AA0	GX	370 (14.57)	620 (24.41)	360 (14.17)	320 (12.6)	105 (4.13)	225 (8.86)	150 (5.91)	208.0

All dimensions in mm (values in brackets are in inches)

Line commutating chokes

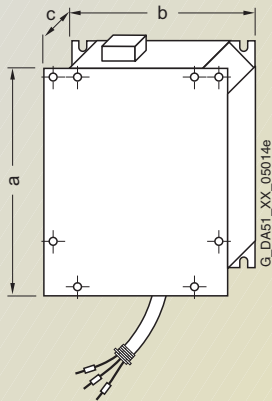

Line commutating choke for	Dimensions			Weight (max.) kg
	a	b	c	
Frame size C	280 (11.02)	185 (7.28)	50 (1.97)	2.3

Line commutating choke for frame size **C**

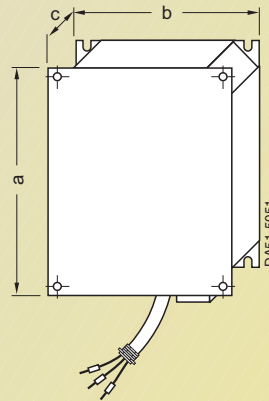

Line commutating choke for	Dimensions			Weight (max.) kg
	a	b	c	
Frame size D	520 (20.47)	275 (10.83)	85 (3.35)	9.5
Frame size E	650 (25.59)	275 (10.83)	95 (3.74)	17.0

Line commutating choke for frame sizes **D** and **E**

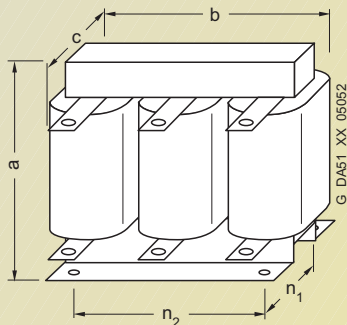

Line commutating choke for inverter frame size **F**

Line commutating choke Type	for inverter Frame size	Dimensions					Weight (max.) kg
		a	b	c	n ₁	n ₂	
3CC11-....	F	228 (8.98)	240 (9.45)	141 (5.55)	95 (3.74)	185 (7.28)	25.0

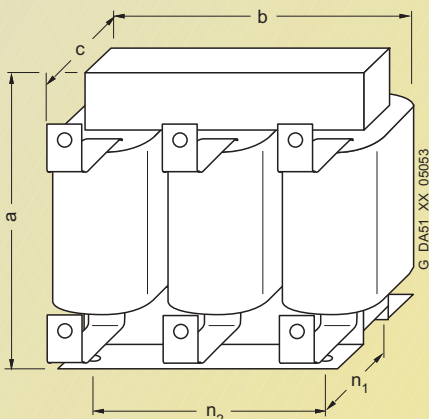

Line commutating choke for inverters of frame sizes **FX** and **GX**

Line commutating choke Type	for inverter Frame size (FS)	Dimensions					Weight (max.) kg
		a	b	c	n ₁	n ₂	
0CE32-....	FX	248 (9.76)	255 (10.04)	203 (7.99)	101 (3.98)	200 (7.87)	24.0
0CE33-....	GX	248 (9.76)	255 (10.04)	203 (7.99)	101 (3.98)	200 (7.87)	25.0
0CE35-....	GX	269 (10.59)	275 (10.83)	210 (8.27)	118 (4.65)	224 (8.82)	35.0

All dimensions in mm (values in brackets are in inches)

Dimension drawings

Output chokes

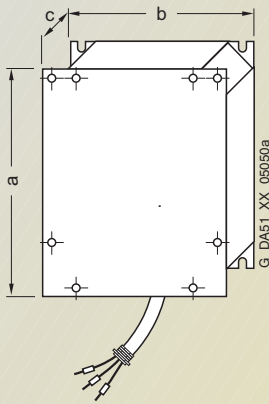

Line commutating choke
for frame size **C**

Output chokes for	Dimensions			Weight (max.) kg
	a	b	c	
Frame size C	245 (9.65)	185 (7.28)	80 (3.15)	5.6

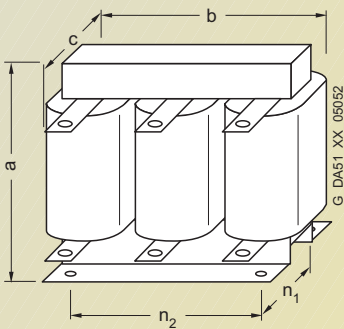

Output chokes
for inverters of size **D, E and F**

Output choke Type	for inverter Frame size (FS)	Dimensions			n ₁	n ₂	Weight (max.) kg
		a	b	c			
6SE6400-					(to DIN 41308)		
3TC03-8DD0	D	210 (8.27)	225 (8.86)	179 (7.05)	94 (3.70)	176 (6.93)	16.1
3TC05-4DD0	D	210 (8.27)	225 (8.86)	150 (5.91)	70 (2.76)	176 (6.93)	10.7
3TC07-5ED0	E	248 (9.76)	270 (10.63)	209 (8.23)	101 (3.98)	200 (7.87)	24.9
3TC08-0ED0	E	210 (8.27)	225 (8.86)	150 (5.91)	70 (2.76)	176 (6.93)	10.4
3TC14-5FD0	F	321 (12.64)	350 (13.78)	288 (11.34)	138 (5.43)	264 (10.39)	51.5
3TC15-4FD0	F	248 (9.76)	270 (10.63)	209 (8.23)	101 (3.98)	200 (7.87)	24.0

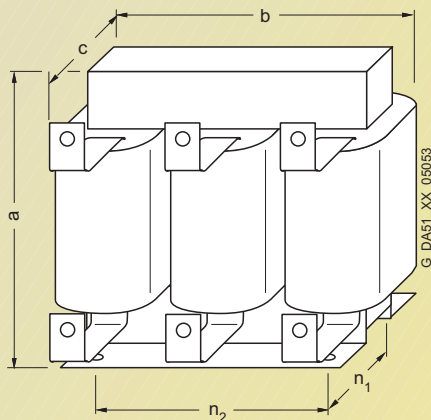

Output chokes
for inverters of size **FX and GX**

Output choke Type	for inverter Frame size (FS)	Dimensions			n ₁	n ₂	Weight (max.) kg
		a	b	c			
6SL3000-							
2BE32-1AA0	FX	285 (11.22)	300 (11.81)	257 (10.12)	163 (6.42)	224 (8.82)	60.0
2BE32-6AA0	FX	315 (12.4)	300 (11.81)	277 (10.91)	183 (7.2)	224 (8.82)	66.0
2BE33-2AA0	GX	285 (11.22)	300 (11.81)	257 (10.12)	163 (6.42)	224 (8.82)	62.0
2BE33-8AA0	GX	285 (11.22)	300 (11.81)	277 (10.91)	183 (7.2)	224 (8.82)	73.0
2BE35-0AA0	GX	365 (14.37)	300 (11.81)	277 (10.91)	183 (7.2)	224 (8.82)	100.0

All dimensions in mm (values in brackets are in inches)

Inverter

MICROMASTER 440



4/2	Description
4/4	Circuit diagrams
4/6	Technical data
4/9	Selection and ordering data
4/12	Options
4/26	Dimension drawings



Description



Applications

The MICROMASTER 440 inverter is suitable for a variety of variable-speed drive applications. Its flexibility provides for a wide spectrum of applications. These also include cranes and hoisting gear, high-bay warehouses, production machines for food, beverages and tobacco, packaging machines etc.; i.e. applications which require the frequency inverter to have a higher functionality and dynamic response than usual.

The inverter is especially characterized by its customer-oriented performance and ease-of-use. Its large mains voltage range enables it to be used all over the world.

Design

The MICROMASTER 440 inverter has a modular design. The operator panels and modules can be easily exchanged.

International standards

- The MICROMASTER 440 inverter complies with the requirements of the EU low-voltage guideline
- The MICROMASTER 440 inverter has the **CE** marking
- acc. to **UL** and **cUL** certified
- c-tick **CCC**

Note:

- See Appendix for standards.

Main characteristics

- Easy, guided start-up
- Modular construction allows maximum configuration flexibility
- Six programmable isolated digital inputs
- Two scaleable analog inputs (0 V to 10 V, 0 mA to 20 mA) can also be used as a 7th/8th digital input
- Two programmable analog outputs (0 mA to 20 mA)
- Three programmable relay outputs (30 V DC/5 A resistive load; 250 V AC/2A inductive load)
- Low-noise motor operation thanks to high pulse frequencies, adjustable (observe derating if necessary)
- Complete protection for motor and inverter.

Options (overview)

- EMC filter, Class A/B
- LC filter and sinusoidal filter
- Line commutating chokes
- Output chokes
- Gland plates
- Basic Operator Panel (BOP) for parameterizing the inverter
- Plain text Advanced Operator Panel (AOP) with multi-language display
- Plain text Asian Advanced Operator Panel (AAOP) with Chinese and English display
- Communication modules
 - PROFIBUS
 - DeviceNet
 - CANopen
- Pulse encoder evaluation module
- PC connection kits
- Mounting kits for installing the operator panels in the control cabinet doors
- PC start-up tools executable under Windows 98 and NT/2000/ME/XP Professional.
- TIA integration with Drive ES

Mechanical features

- Modular design
- Operating temperature
0.12 kW to 75 kW:
-10 °C to +50 °C
(+14 °F to +122 °F)
90 kW to 200 kW:
0 °C to +40 °C
(+32 °F to +104 °F)
- Compact housing as a result of high power density
- Easy cable connection, mains and motor connections are separated for optimum electromagnetic compatibility
- Detachable operator panels
- Screwless control terminals on detachable I/O board.

Performance features

- Latest IGBT technology
- Digital microprocessor control
- High-quality Vector Control system
- Flux Current Control (FCC) for improved dynamic response and optimized motor control
- Linear V/f characteristic
- Quadratic V/f characteristic
- Multipoint characteristic (programmable V/f characteristic)
- Torque control
- Flying restart
- Slip compensation
- Automatic restart following mains failure or fault
- User-definable function blocks for logic and arithmetic operations
- Kinetic buffering
- Positioning ramp down
- High-grade PID controller for simple internal process control (autotuning)
- Programmable acceleration/deceleration, 0 s to 650 s
- Ramp smoothing
- Fast Current Limit (FCL) for trip-free operation
- Fast, repeatable digital input response time
- Fine adjustment using two high-resolution 10-bit analog inputs
- Compound braking for controlled rapid braking
- Integrated brake chopper (for 0.12 kW to 75 kW inverters)
- Four skip frequencies
- Removable "Y" capacitor for use on IT systems (with non-grounded mains supplies, the "Y" capacitor must be removed and an output choke installed).

Protection features

- Overload capability
 - **CT mode**
0.12 kW to 75 kW:
Overload current 1.5 x rated output current (i.e. 150 % overload capability) for 60 s, cycle time 300 s, and 2 x rated output current (i.e. 200 % overload capability) for 3 s, cycle time 300 s
 - 90 kW to 200 kW:
Overload current 1.36 x rated output current (i.e. 136 % overload capability) for 57 s, cycle time 300 s, and 1.6 x rated output current (i.e. 160 % overload capability) for 3 s, cycle time 300 s
 - **VT mode**
5.5 kW to 90 kW:
Overload current 1.4 x rated output current (i.e. 140 % overload capability) for 3 s, and 1.1 x rated output current (i.e. 110 % overload capability) for 60 s, cycle time 300 s
 - 110 kW to 250 kW:
Overload current 1.5 x rated output current (i.e. 150 % overload capability) for 1 s, and 1.1 x rated output current (i.e. 110 % overload capability) for 59 s, cycle time 300 s
- Overvoltage/undervoltage protection
- Inverter overtemperature protection
- Special direct connection for PTC or KTY to protect the motor
- Earth fault protection
- Short-circuit protection
- βt motor thermal protection
- Locked motor protection
- Stall prevention
- Parameter interlock.

Circuit diagrams

General circuit diagram

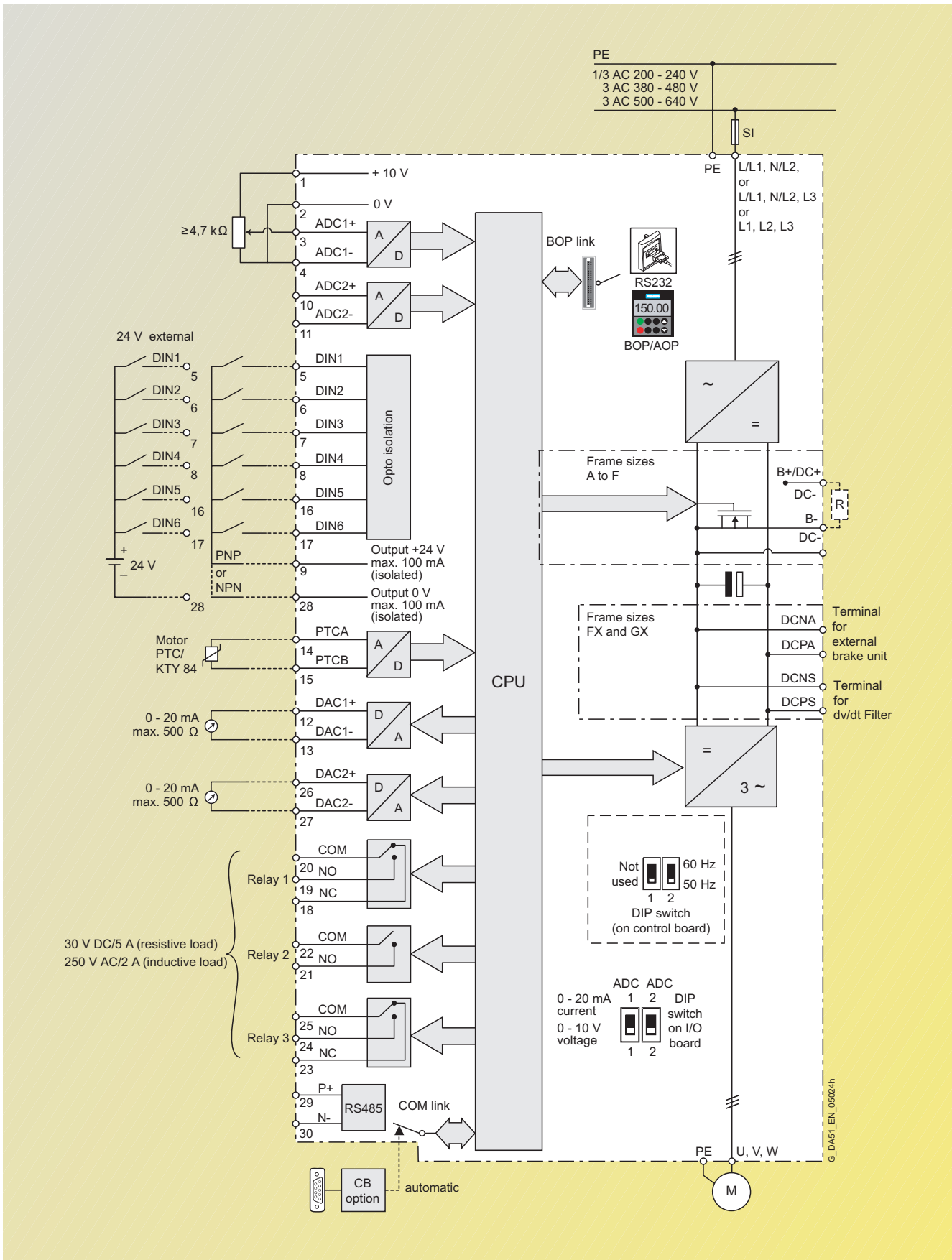

Terminal connection diagram

Example, frame size FX

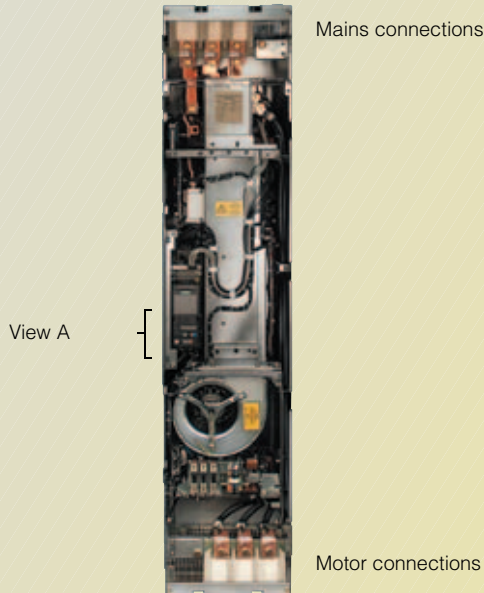

View A

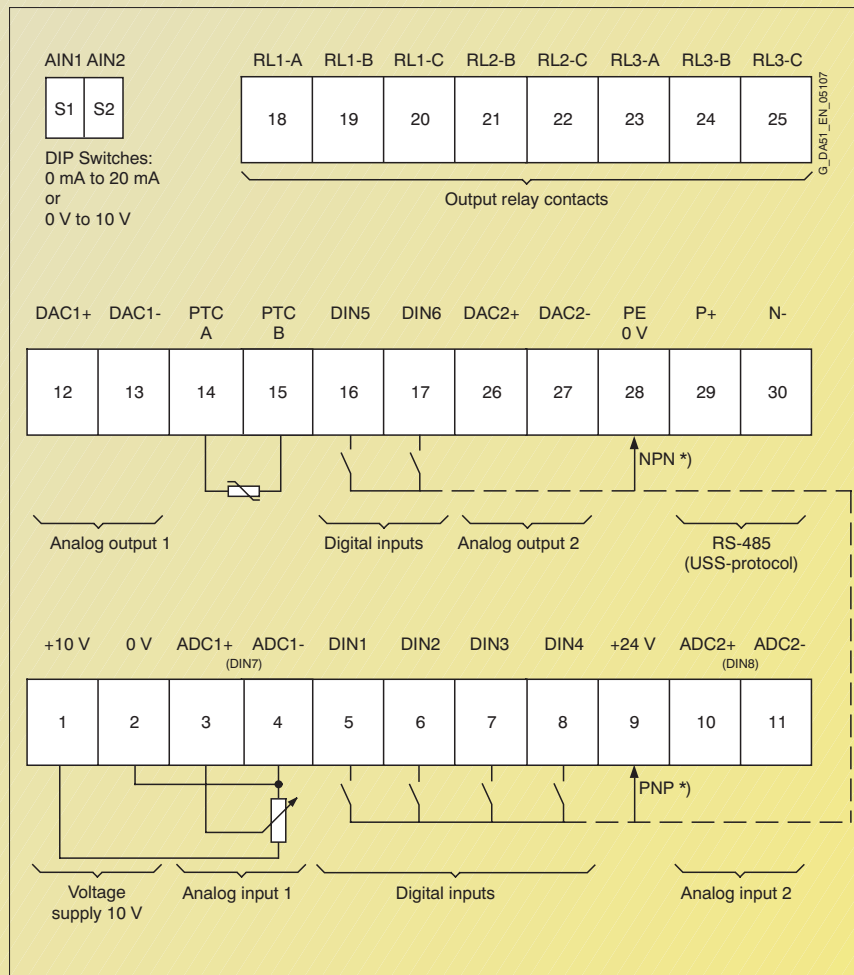

*) PNP or NPN possible

Technical data

MICROMASTER 440 inverter

Mains voltage and power ranges		1 AC 200 V to 240 V ± 10 % 3 AC 200 V to 240 V ± 10 % 3 AC 380 V to 480 V ± 10 % 3 AC 500 V to 600 V ± 10 %	CT (constant torque) 0.12 kW to 3 kW 0.12 kW to 45 kW 0.37 kW to 200 kW 0.75 kW to 75 kW	VT (variable torque) – 5.5 kW to 45 kW 7.5 kW to 250 kW 1.5 kW to 90 kW
Input frequency		47 Hz to 63 Hz		
Output frequency	0.12 kW to 75 kW 90 kW to 200 kW	0 Hz to 650 Hz (in V/f mode) 0 Hz to 267 Hz (in V/f mode)	0 Hz to 200 Hz (in vector mode) 0 Hz to 200 Hz (in vector mode)	
Power factor		≥ 0.95		
Inverter efficiency		0.12 kW to 75 kW: 96 % to 97 %; 90 kW to 200 kW: 97 % to 98 %		
Overload capability		Overload current 1.5 x rated output current (i.e. 150 % overload capability) for 60 s, cycle time 300 s and 2 x rated output current (i.e. 200 % overload capability) for 3 s, cycle time 300 s		
– CT mode	0.12 kW to 75 kW 90 kW to 200 kW	Overload current 1.36 x rated output current (i.e. 136 % overload capability) for 57 s, cycle time 300 s and 1.6 x rated output current (i.e. 160 % overload capability) for 3 s, cycle time 300 s		
– VT mode	5.5 kW to 90 kW 110 kW to 250 kW	Overload current 1.4 x rated output current (i.e. 140 % overload capability) for 3 s, and 1.1 x rated output current (i.e. 110 % overload capability) for 60 s, cycle time 300 s Overload current 1.5 x rated output current (i.e. 150 % overload capability) for 1 s, and 1.1 x rated output current (i.e. 110 % overload capability) for 59 s, cycle time 300 s		
Inrush current		not higher than rated input current		
Control method		Vector control, torque control, linear V/f characteristic; quadratic V/f characteristic; Multipoint characteristic (programmable V/f characteristic); flux current control (FCC)		
Pulse frequency	0.12 kW to 75 kW 90 kW to 200 kW	4 kHz (standard); 16 kHz (standard with 230 V inverters 0.12 kW to 5.5 kW) 2 kHz to 16 kHz (in 2 kHz steps) 2 kHz (standard with VT mode); 4 kHz (standard with CT mode) 2 kHz to 4 kHz (in 2 kHz steps)		
Fixed frequencies		15, programmable		
Skip frequency ranges		4, programmable		
Setpoint resolution		0.01 Hz digital 0.01 Hz serial 10 bit analog		
Digital inputs		6 fully programmable isolated digital inputs; switchable PNP/NPN		
Analog inputs		2 programmable analog inputs • 0 V to 10 V, 0 mA to 20 mA and –10 V to +10 V (AIN1) • 0 V to 10 V and 0 mA to 20 mA (AIN2) • both can be used as 7th/8th digital input		
Relay outputs		3, programmable, 30 V DC/5 A (resistive load); 250 V AC/2A (inductive load)		
Analog outputs		2, programmable (0/4 mA to 20 mA)		
Serial interfaces		RS-485, optional RS-232		
Motor cable lengths without output choke	0.12 – 75 kW 90 – 250 kW	max. 50 m (shielded), max. 100 m (unshielded) max. 100 m (shielded), max. 150 m (unshielded)		
with output choke		see variant dependent options		
Electromagnetic compatibility (see Selection and Ordering Data)		EMC filter, Class A or Class B to EN 55 011 available as an option Inverter with internal filter Class A available		
Braking		Resistance braking with DC braking, compound braking, integrated brake chopper (integrated brake chopper only with 0.12 kW to 75 kW inverters)		
Degree of protection		IP20		
Operating temperature (without derating)	0.12 kW to 75 kW 90 kW to 200 kW	CT: –10 °C to +50 °C (+14 °F to +122 °F) VT: –10 °C to +40 °C (+14 °F to +104 °F) 0 °C to +40 °C (+32 °F to +104 °F)		
Storage temperature		–40 °C to +70 °C (–40 °F to +158 °F)		
Relative humidity		95% (non-condensing)		
Installation altitude	0.12 kW to 75 kW 90 kW to 200 kW	up to 1000 m above sea level without derating up to 2000 m above sea level without derating		
Protection features for		Undervoltage, overvoltage, overload, earth faults, short-circuits, stall prevention, locked motor protection, motor over-temperature, inverter overtemperature, parameter change protection		
Compliance with standards		Ⓜ, cⓂ, CE, c-tick		
CE marking		Conformity with low-voltage directive 73/23/EEC		
Cooling-air volumetric flow required, dimensions and weights (without options)		Frame size (FS)	Cooling-air volumetric flow required (l/s)/(CFM)	H x W x D, max. (mm) Weight, approx. (kg)
		A	4.8/10.2	173 x 73 x 149 1.3
		B	24/51	202 x 149 x 172 3.4
		C	54.9/116.3	245 x 185 x 195 5.7
		D	2 x 54.9/2 x 116.3	520 x 275 x 245 17
		E	2 x 54.9/2 x 116.3	650 x 275 x 245 22
		F without filter	150/317.79	850 x 350 x 320 56
		F with filter	150/317.79	1150 x 350 x 320 75
		FX	225/478.13	1400 x 326 x 356 116
		GX	440/935	1533 x 326 x 545 176

CFM: Cubic Flow per Minute

Derating data

Pulse frequency

Output kW	Rated output current in A for a pulse frequency of						
	4 kHz	6 kHz	8 kHz	10 kHz	12 kHz	14 kHz	16 kHz
Mains voltage 1/3 AC 200 V							
0.12 to 5.5	Values correspond to the 4 kHz standard values. No derating, since 16 kHz standard.						
7.5	28.0	26.6	25.2	22.4	19.6	16.8	14.0
11	42.0	37.8	33.6	29.4	25.2	21.0	16.8
15	54.0	48.6	43.2	37.8	32.4	27.0	21.6
18.5	68.0	64.6	61.2	54.4	47.6	40.8	34.0
22	80.0	72.0	64.0	56.0	48.0	40.0	32.0
30	104.0	91.0	78.0	70.2	62.4	57.2	52.0
37	130.0	113.8	97.5	87.8	78.0	71.5	65.0
45	154.0	134.8	115.5	104.0	92.4	84.7	77.0

Mains operating voltage 3 AC 400 V

0.37	1.3	1.3	1.3	1.3	1.3	1.2	1.0
0.55	1.7	1.7	1.7	1.6	1.5	1.4	1.2
0.75	2.2	2.2	2.2	2.0	1.8	1.5	1.3
1.1	3.1	2.9	2.8	2.5	2.2	1.9	1.6
1.5	4.1	3.7	3.3	2.9	2.5	2.1	1.6
2.2	5.9	5.6	5.3	4.7	4.1	3.5	3.0
3.0	7.7	6.9	6.2	5.4	4.6	3.9	3.1
4.0	10.2	9.2	8.2	7.1	6.1	5.1	4.1
5.5	13.2	11.9	10.6	9.2	7.9	6.6	5.3
7.5	19.0	18.1	17.1	15.2	13.3	11.4	9.5
11.0	26.0	23.4	20.8	18.2	15.6	13.0	10.4
15.0	32.0	30.4	28.8	25.6	22.4	19.2	16.0
18.5	38.0	34.2	30.4	26.6	22.8	19.0	15.2
22	45.0	40.5	36.0	31.5	27.0	22.5	18.0
30	62.0	58.9	55.8	49.6	43.4	37.2	31.0
37	75.0	67.5	60.0	52.5	45.0	37.5	30.0
45	90.0	76.5	63.0	51.8	40.5	33.8	27.0
55	110.0	93.5	77.0	63.3	49.5	41.3	33.0
75	145.0	112.4	79.8	68.9	58.0	50.8	43.5
90	178.0	–	–	–	–	–	–
110	205.0	–	–	–	–	–	–
132	250.0	–	–	–	–	–	–
160	302.0	–	–	–	–	–	–
200	370.0	–	–	–	–	–	–

Mains operating voltage 3 AC 500 V

0.75	1.4	1.2	1.0	0.8	0.7	0.6	0.6
1.5	2.7	2.2	1.6	1.4	1.1	0.9	0.8
2.2	3.9	2.9	2.0	1.6	1.2	1.0	0.8
4.0	6.1	4.6	3.1	2.4	1.8	1.5	1.2
5.5	9.0	6.8	4.5	3.6	2.7	2.3	1.8
7.5	11.0	8.8	6.6	5.5	4.4	3.9	3.3
11.0	17.0	12.8	8.5	6.8	5.1	4.3	3.4
15.0	22.0	17.6	13.2	11.0	8.8	7.7	6.6
18.5	27.0	20.3	13.5	10.8	8.1	6.8	5.4
22	32.0	24.0	16.0	12.8	9.6	8.0	6.4
30	41.0	32.8	24.6	20.5	16.4	14.4	12.3
37	52.0	39.0	26.0	20.8	15.6	13.0	10.4
45	62.0	52.7	43.4	40.3	37.2	32.6	27.9
55	77.0	67.4	57.8	52.0	46.2	42.4	38.5
75	99.0	84.2	69.3	64.4	59.4	52.0	44.6

Technical data

Derating data (continued)

Operating temperature

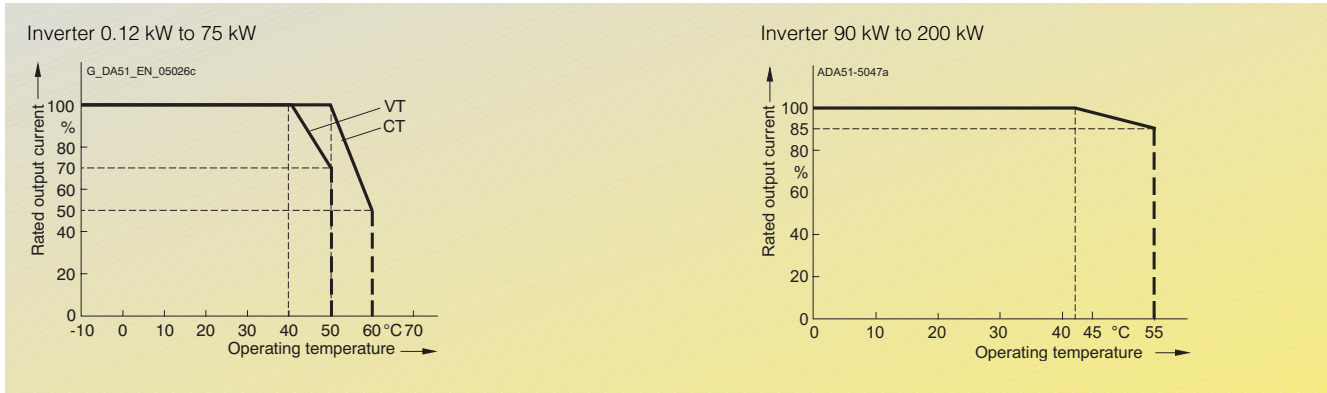

Installation height above sea level

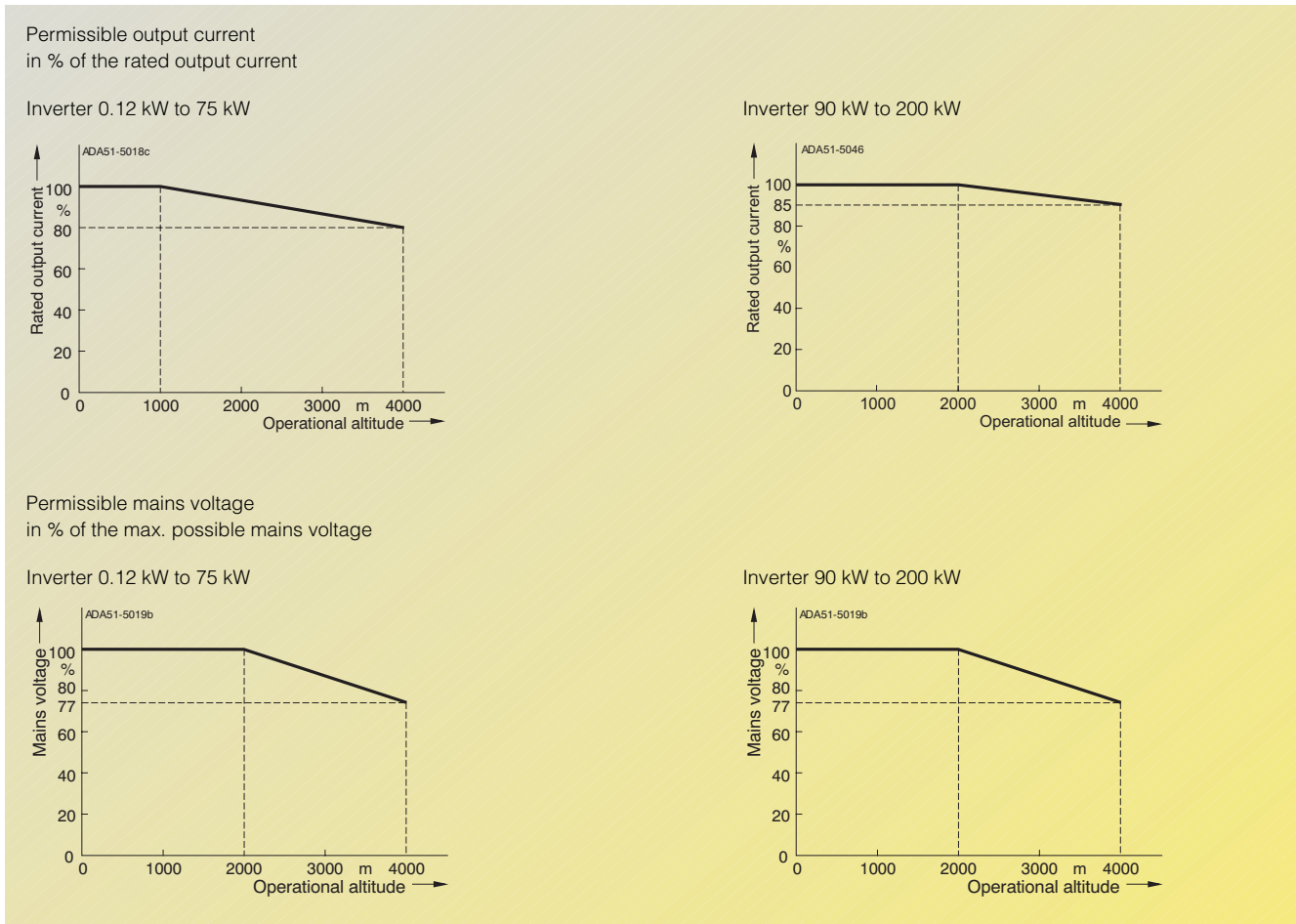

4

MICROMASTER 440 inverter without filter²⁾

CT (constant torque)				VT (variable torque)				MICROMASTER 440 without filter ²⁾		
Output		Rated input current ¹⁾	Rated output current	Output		Rated input current ¹⁾	Rated output current	Frame size	Weight, approx.	Order No.
kW	hp	A	A	kW	hp	A	A	(FS)	kg	
Mains voltage 1 AC 200 V to 240 V										
0.12	0.16	1.8	0.9	–	–	–	–	A	1.3	6SE6440-2UC11-2AA1
0.25	0.33	3.2	1.7	–	–	–	–	A	1.3	6SE6440-2UC12-5AA1
0.37	0.50	4.6	2.3	–	–	–	–	A	1.3	6SE6440-2UC13-7AA1
0.55	0.75	6.2	3.0	–	–	–	–	A	1.3	6SE6440-2UC15-5AA1
0.75	1.0	8.2	3.9	–	–	–	–	A	1.3	6SE6440-2UC17-5AA1
1.1	1.5	11.0	5.5	–	–	–	–	B	3.3	6SE6440-2UC21-1BA1
1.5	2	14.4	7.4	–	–	–	–	B	3.3	6SE6440-2UC21-5BA1
2.2	3	20.2	10.4	–	–	–	–	B	3.3	6SE6440-2UC22-2BA1
3.0	4	35.5	13.6	–	–	–	–	C	5.5	6SE6440-2UC23-0CA1
Mains operating voltage 3 AC 200 V to 240 V										
0.12	0.16	1.1	0.9	–	–	–	–	A	1.3	6SE6440-2UC11-2AA1
0.25	0.33	1.9	1.7	–	–	–	–	A	1.3	6SE6440-2UC12-5AA1
0.37	0.50	2.7	2.3	–	–	–	–	A	1.3	6SE6440-2UC13-7AA1
0.55	0.75	3.6	3.0	–	–	–	–	A	1.3	6SE6440-2UC15-5AA1
0.75	1.0	4.7	3.9	–	–	–	–	A	1.3	6SE6440-2UC17-5AA1
1.1	1.5	6.4	5.5	–	–	–	–	B	3.3	6SE6440-2UC21-1BA1
1.5	2.0	8.3	7.4	–	–	–	–	B	3.3	6SE6440-2UC21-5BA1
2.2	3.0	11.7	10.4	–	–	–	–	B	3.3	6SE6440-2UC22-2BA1
3.0	4.0	15.6	13.6	–	–	–	–	C	5.5	6SE6440-2UC23-0CA1
4.0	5.0	19.7	17.5	5.5	7.5	28.3	22	C	5.5	6SE6440-2UC24-0CA1
5.5	7.5	26.5	22	7.5	10	34.2	28	C	5.5	6SE6440-2UC25-5CA1
7.5	10	34.2	28	11.0	15	38.0	42	D	16	6SE6440-2UC27-5DA1
11.0	15	38.0	42	15.0	20	50.0	54	D	16	6SE6440-2UC31-1DA1
15.0	20	50.0	54	18.5	25	62.0	68	D	16	6SE6440-2UC31-5DA1
18.5	25	62.0	68	22	30	71.0	80	E	20	6SE6440-2UC31-8EA1
22	30	71.0	80	30	40	96.0	104	E	20	6SE6440-2UC32-2EA1
30	40	96.0	104	37	50	114.0	130	F	55	6SE6440-2UC33-0FA1
37	50	114.0	130	45	60	135.0	154	F	55	6SE6440-2UC33-7FA1
45	60	135.0	154	55	75	164.0	178	F	55	6SE6440-2UC34-5FA1
Mains operating voltage 3 AC 380 V to 480 V										
0.37	0.50	2.2	1.3	–	–	–	–	A	1.3	6SE6440-2UD13-7AA1
0.55	0.75	2.8	1.7	–	–	–	–	A	1.3	6SE6440-2UD15-5AA1
0.75	1.0	3.7	2.2	–	–	–	–	A	1.3	6SE6440-2UD17-5AA1
1.1	1.5	4.9	3.1	–	–	–	–	A	1.3	6SE6440-2UD21-1AA1
1.5	2.0	5.9	4.1	–	–	–	–	A	1.3	6SE6440-2UD21-5AA1
2.2	3.0	7.5	5.9	–	–	–	–	B	3.3	6SE6440-2UD22-2BA1
3.0	4.0	10.0	7.7	–	–	–	–	B	3.3	6SE6440-2UD23-0BA1
4.0	5.0	12.8	10.2	–	–	–	–	B	3.3	6SE6440-2UD24-0BA1
5.5	7.5	15.6	13.2	7.5	10	17.3	19	C	5.5	6SE6440-2UD25-5CA1
7.5	10	22.0	19	11.0	15	23.1	26	C	5.5	6SE6440-2UD27-5CA1
11.0	15	23.1	26	15.0	20	33.8	32	C	5.5	6SE6440-2UD31-1CA1
15.0	20	33.8	32	18.5	25	37.0	38	D	16	6SE6440-2UD31-5DA1
18.5	25	37.0	38	22	30	43.0	45	D	16	6SE6440-2UD31-8DA1
22	30	43.0	45	30	40	59.0	62	D	16	6SE6440-2UD32-2DA1
30	40	59.0	62	37	50	72.0	75	E	20	6SE6440-2UD33-0EA1
37	50	72.0	75	45	60	87.0	90	E	20	6SE6440-2UD33-7EA1
45	60	87.0	90	55	75	104.0	110	F	56	6SE6440-2UD34-5FA1
55	75	104.0	110	75	100	139.0	145	F	56	6SE6440-2UD35-5FA1
75	100	139.0	145	90	125	169.0	178	F	56	6SE6440-2UD37-5FA1

1) Supplementary conditions:
Input current at rated operating point, applicable at short-circuit voltage of the supply $U_{sc} = 2\%$ with reference to the inverter rated power and rated mains operating voltage of 240 V or 400 V without a line commutating choke.

2) Generally suited to heavy industrial applications. For details please refer to Appendix on page A/4.

Selection and ordering data

MICROMASTER 440 inverter without filter³⁾ (continued)

CT (constant torque)			VT (variable torque)				MICROMASTER 440 without filter ³⁾			
Output		Rated input current	Rated output current	Output		Rated input current	Rated output current	Frame size	Weight, approx.	Order No.
kW	hp	A	A	kW	hp	A	A	(FS)	kg	
Mains operating voltage 3 AC 380 V to 480 V										
90	125	169.0 ¹⁾	178	110	150	200.0 ¹⁾	205	FX	110	6SE6440-2UD38-8FA1
110	150	200.0 ¹⁾	205	132	200	245.0 ¹⁾	250	FX	116	6SE6440-2UD41-1FA1
132	200	245.0 ¹⁾	250	160	250	297.0 ¹⁾	302	GX	170	6SE6440-2UD41-3GA1
160	250	297.0 ¹⁾	302	200	300	354.0 ¹⁾	370	GX	174	6SE6440-2UD41-6GA1
200	300	354.0 ¹⁾	370	250	350	442.0 ¹⁾	477	GX	176	6SE6440-2UD42-0GA1
Mains operating voltage 3 AC 500 V to 600 V										
0.75	1.0	2.0 ²⁾	1.4	1.5	2.0	3.2 ²⁾	2.7	C	5.5	6SE6440-2UE17-5CA1
1.5	2.0	3.7 ²⁾	2.7	2.2	3.0	4.4 ²⁾	3.9	C	5.5	6SE6440-2UE21-5CA1
2.2	3.0	5.3 ²⁾	3.9	4.0	5.0	6.9 ²⁾	6.1	C	5.5	6SE6440-2UE22-2CA1
4.0	5.0	8.1 ²⁾	6.1	5.5	7.5	9.4 ²⁾	9	C	5.5	6SE6440-2UE24-0CA1
5.5	7.5	11.1 ²⁾	9	7.5	10	12.6 ²⁾	11	C	5.5	6SE6440-2UE25-5CA1
7.5	10	14.4 ²⁾	11	11.0	15	18.1 ²⁾	17	C	5.5	6SE6440-2UE27-5CA1
11.0	15	21.5 ²⁾	17	15.0	20	24.9 ²⁾	22	C	5.5	6SE6440-2UE31-1CA1
15.0	20	24.9 ²⁾	22	18.5	25	30.0 ²⁾	27	D	16	6SE6440-2UE31-5DA1
18.5	25	30.0 ²⁾	27	22	30	35.0 ²⁾	32	D	16	6SE6440-2UE31-8DA1
22	30	35.0 ²⁾	32	30	40	48.0 ²⁾	41	D	16	6SE6440-2UE32-2DA1
30	40	48.0 ²⁾	41	37	50	58.0 ²⁾	52	E	20	6SE6440-2UE33-0EA1
37	50	58.0 ²⁾	52	45	60	69.0 ²⁾	62	E	20	6SE6440-2UE33-7EA1
45	60	69.0 ²⁾	62	55	75	83.0 ²⁾	77	F	56	6SE6440-2UE34-5FA1
55	75	83.0 ²⁾	77	75	100	113.0 ²⁾	99	F	56	6SE6440-2UE35-5FA1
75	100	113.0 ²⁾	99	90	120	138.0 ²⁾	125	F	56	6SE6440-2UE37-5FA1



See Appendix for note on ordering.

All MICROMASTER 440 inverters are supplied with a Status Display Panel (SDP). A BOP, AOP or other options have to be ordered separately (see Pages 4/16 to 4/22).

Motors for MICROMASTER 440

Catalog M 11 contains selection and ordering data for motors which are particularly suitable for operation with the MICROMASTER 440 inverters (see Appendix for overview).

This catalog is suitable for IEC motors. For motors according to US standards (NEMA) please refer to: <http://www.sea.siemens.com/motors>

1) Supplementary conditions: Input current at rated operating point, applicable at short-circuit voltage of the supply $U_{sc} \geq 2.33\%$ with reference to the inverter rated power and rated mains operating voltage of 400 V.

2) Supplementary conditions: Input current at rated operating point, applicable at short-circuit voltage of the supply $U_{sc} = 2\%$ with reference to the inverter rated power and rated mains operating voltage of 500 V without a line commutating choke.

3) Generally suited to heavy industrial applications. For details please refer to Appendix on page A/4.

MICROMASTER 440 inverter with internal filter Class A

CT (constant torque)				VT (variable torque)				MICROMASTER 440 with internal filter Class A ²⁾		
Output		Rated input current ¹⁾	Rated output current	Output		Rated input current ¹⁾	Rated output current	Frame size (FS)	Weight, approx. kg	Order No.
kW	hp	A	A	kW	hp	A	A			
Mains operating voltage 1 AC 200 V to 240 V										
0.12	0.16	1.8	0.9	–	–	–	–	A	1.3	6SE6440-2AB11-2AA1
0.25	0.33	3.2	1.7	–	–	–	–	A	1.3	6SE6440-2AB12-5AA1
0.37	0.50	4.6	2.3	–	–	–	–	A	1.3	6SE6440-2AB13-7AA1
0.55	0.75	6.2	3.0	–	–	–	–	A	1.3	6SE6440-2AB15-5AA1
0.75	1.0	8.2	3.9	–	–	–	–	A	1.3	6SE6440-2AB17-5AA1
1.1	1.5	11.0	5.5	–	–	–	–	B	3.4	6SE6440-2AB21-1BA1
1.5	2	14.4	7.4	–	–	–	–	B	3.4	6SE6440-2AB21-5BA1
2.2	3	20.2	10.4	–	–	–	–	B	3.4	6SE6440-2AB22-2BA1
3.0	4	35.5	13.6	–	–	–	–	C	5.7	6SE6440-2AB23-0CA1
Mains operating voltage 3 AC 200 V to 240 V										
3.0	4.0	15.6	13.6	–	–	–	–	C	5.7	6SE6440-2AC23-0CA1
4.0	5.0	19.7	17.5	5.5	7.5	28.3	22	C	5.7	6SE6440-2AC24-0CA1
5.5	7.5	26.5	22.0	7.5	10.0	34.2	28	C	5.7	6SE6440-2AC25-5CA1
Mains operating voltage 3 AC 380 V to 480 V										
2.2	3.0	7.5	5.9	–	–	–	–	B	3.4	6SE6440-2AD22-2BA1
3.0	4.0	10.0	7.7	–	–	–	–	B	3.4	6SE6440-2AD23-0BA1
4.0	5.0	12.8	10.2	–	–	–	–	B	3.4	6SE6440-2AD24-0BA1
5.5	7.5	15.6	13.2	7.5	10	17.6	19	C	5.7	6SE6440-2AD25-5CA1
7.5	10	22.0	18.4	11.0	15	23.1	26	C	5.7	6SE6440-2AD27-5CA1
11.0	15	23.1	26	15.0	20	33.8	32	C	5.7	6SE6440-2AD31-1CA1
15.0	20	33.8	32	18.5	25	37.0	38	D	17	6SE6440-2AD31-5DA1
18.5	25	37.0	38	22	30	43.0	45	D	17	6SE6440-2AD31-8DA1
22	30	43.0	45	30	40	59.0	62	D	17	6SE6440-2AD32-2DA1
30	40	59.0	62	37	50	72.0	75	E	22	6SE6440-2AD33-0EA1
37	50	72.0	75	45	60	87.0	90	E	22	6SE6440-2AD33-7EA1
45	60	87.0	90	55	75	104.0	110	F	75	6SE6440-2AD34-5FA1
55	75	104.0	110	75	100	139.0	145	F	75	6SE6440-2AD35-5FA1
75	100	139.0	145	90	125	169.0	178	F	75	6SE6440-2AD37-5FA1



See Appendix for note on ordering.

All MICROMASTER 440 inverters are supplied with a Status Display Panel (SDP). A BOP, AOP or other options have to be ordered separately (see Pages 4/16 to 4/22).

Motors for MICROMASTER 440

Catalog M 11 contains selection and ordering data for motors which are particularly suitable for operation with the MICROMASTER 440 inverters (see Appendix for overview).

This catalog is suitable for IEC motors. For motors according to US standards (NEMA) please refer to: <http://www.sea.siemens.com/motors>

1) Supplementary conditions:
Input current at rated operating point, applicable at short-circuit voltage of the supply $U_{sc} = 2\%$ with reference to the inverter rated power and rated mains operating voltage of 240 V or 400 V without a line commutating choke.

2) Use of MICROMASTER inverters with internal filter is not permissible on non-grounded mains supplies.

Options Variant dependent options

Overview

EMC filter, Class A

Filter for inverters without an internal filter for

- 3 AC 200 V to 240 V, frame sizes A and B
- 3 AC 380 V to 480 V, frame size A, FX, GX

Filters for frame sizes FX and GX are only permitted to be used in combination with a line commutating choke.

All other inverters can be supplied with an internal Class A filter.

The requirements are fulfilled using shielded cables with a max. length of 25 m.

EMC filter, Class B

Filter for inverters without an internal filter for

- 3 AC 200 V to 240 V, frame sizes A and B
- 3 AC 380 V to 480 V, frame size A.

The requirements are fulfilled using shielded cables with a max. length of 25 m.

For inverters 15 kW to 75 kW without filters, EMC filters of Class B from Schaffner can be used.

The requirements are fulfilled using shielded cables with a max. length of 25 m to 50 m (depending on the type, details on request).

With this filter, the inverter complies with the emission standard EN 55 011, Class B.

Additional EMC filter, Class B

Available for inverters with an internal Class A EMC filter, frame sizes A, B and C.

The requirements are fulfilled using shielded cables with a max. length of 25 m.

With this filter, the inverter complies with the emission standard EN 55 011, Class B.

Filter Class B with low leakage currents

EMC filter for 1 AC 200 V to 240 V inverters, frame sizes A and B, without an internal EMC filter Class A.

With this filter, the inverter complies with the emission standard EN 55 011, Class B. The leakage currents are reduced to < 3.5 mA.

The requirements are fulfilled using shielded cables with a max. length of 5 m.

Leakage currents:

The leakage currents of the inverters with/without filter (internal/external) may exceed 30 mA. Typical values in practice are between 10 mA and 50 mA. The exact values depend on the design, environment and cable lengths. Interference-free operation with

residual current operated devices with a trigger value of 30 mA cannot be guaranteed. However, operation with residual current circuit-breakers with a trigger value of 300 mA is possible. Please refer to the Instruction Manual for details.

LC filter and sinusoidal filter

The LC filter/sinusoidal filter limits the rate of rise of voltage and the capacitive charge/discharge currents which usually occur with inverter operation. This means that much longer shielded motor cables are possible when using LC filters/sinusoidal filters and the service life of the motor achieves values similar to those with direct mains operation. Use of an output choke isn't required with that.

Please note when using LC filters/sinusoidal filters:

- Only V/f, FCC control permissible
- Please observe the derating of 15 % when selecting the appropriate inverter
- Operation only permissible with 4 kHz pulse frequency
Note: Please observe derating for frame sizes FX and GX.
- The output frequency is limited to 150 Hz.

The LC filters/sinusoidal filters can be used for all MICRO-MASTER 440 inverters of frame sizes A to GX.

- Frame sizes D to F:
The LC filters, frame sizes D to F, are designed for mounting upright in the control cabinet. Due to leakage flux lines caused by physical sources, a minimum distance of 50 mm to adjacent modules and metal parts is recommended.

- Frame sizes FX and GX:
The sinusoidal filters, frame sizes FX and GX, are designed for mounting upright in the control cabinet. Due to leakage flux lines caused by physical sources, a minimum distance of 100 mm to adjacent modules and metal parts is recommended.

Technical data

LC filter and sinusoidal filter

Mains voltage	3 AC 380 V to 480 V	3 AC 500 V to 600 V
Current (at 40 °C/50 °C)		
For frame size A (0.37 to 1.5 kW)	4.5 A/4.1 A	–
For frame size B (2.2 to 4 kW)	11.2 A/10.2 A	–
For frame size C (0.75 to 4 kW)	–	9.0 A/6.1 A
For frame size C (5.5 to 11 kW)	32.6 A/29.7 A	22.4 A/17 A
For frame size D (15 kW)	38.8 A/32 A	27.5 A/22 A
For frame size D (18.5 kW)	45.9 A/38 A	32.6 A/27 A
For frame size D (22 kW)	63.2 A/45 A	41.8 A/32 A
For frame size E (30 kW)	76.5 A/62 A	53 A/41 A
For frame size E (37 kW)	112.2 A/90 A	63.2 A/52 A
For frame size F (45 kW)	112.2 A/90 A	78.5 A/62 A
For frame size F (55 kW)	147.9 A/110 A	101 A/77 A
For frame size F (75 kW)	181.6 A/145 A	127.5 A/99 A
For frame size FX (90 kW and 110 kW)	225 A/191 A	–
For frame size GX (132 kW)	276 A/235 A	–
For frame size GX (160 kW)	333 A/283 A	–
For frame size GX (200 kW)	408 A/347 A	–

Technical data (continued)

LC filter and sinusoidal filter

Limiting of motor overvoltage	≤ 1078 V	
dV/dt limiting	≤ 500 V/μs	
Pulse frequency	4 kHz	
Max. motor frequency	150 Hz	
Max. permissible motor cable lengths		
For frame sizes A to F	shielded	200 m
	unshielded	300 m
For frame sizes FX and GX	shielded	300 m
	unshielded	450 m
Insulation strength	Overvoltage category III to VDE 0110	
Electromagnetic compatibility		
For frame sizes A to F	Up to 200 m motor cable length with emissions to Class A according to EN 55 011 in conjunction with filtered inverters and unshielded cables	
For frame sizes FX and GX	Up to 150 m motor cable length with emissions to Class A according to EN 55 011 in conjunction with filtered inverters and unshielded cables	
Conformity	CE according to the low-voltage directive 73/23/EEC	
Approvals	cUL E 219022	
Strain resistance	EN 60 068-2-31	
Humidity	95 % humidity, non-condensing	
Degree of protection		
For frame sizes A to C	IP20 (to EN 60 529)	
For frame sizes D to F	IP00/IP20 (to EN 60 529 with terminal covers)	
For frame sizes FX and GX	IP00	
Insulation class	H (180 °C)	
Temperature range		
For frame sizes A to F	Operation	-10 °C to +40 °C (+14 °F to +104 °F) to +50 °C (to +122 °F) 100 % P_n 80 % P_n
	Storage	-25 °C to +70 °C (-13 °F to +158 °F)
For frame sizes FX and GX	Operation	-10 °C to +40 °C (+14 °F to +104 °F) to +55 °C (to +131 °F) 100 % P_n 80 % P_n
	Storage	-40 °C to +70 °C (-40 °F to +158 °F)
Installation altitude		
For frame sizes A to C	Up to 2000 m:	100 % P_n
	2000 to 4000 m:	62.5 % P_n
For frame sizes D to F	Up to 1000 m:	100 % P_n
	1000 to 4000 m:	12.5 % derating for each 1000 m
For frame sizes FX and GX	Up to 2000 m:	100 % P_n
	2000 to 4000 m:	7.5 % derating for each 1000 m
Mounting position		
For frame sizes A to C	Footprint or suspended	
For frame sizes D to F, FX and GX	upright	
Ventilation clearances		
For frame sizes A to C	Top	100 mm
	Bottom	100 mm
	Side	100 mm
For frame sizes D to F, FX and GX	Top	100 mm
	Side	100 mm
Connection system	Input, litz wire or terminal	1U1, 1V1, 1W1
	Output, terminals	1U2, 1V2, 1W2
Torque for conductor connections	Terminal cross-section	Torque
For frame sizes A to C	-	1.5 Nm to 1.8 Nm
For frame sizes D to F	16 mm ²	2.0 Nm to 4.0 Nm
	35 mm ²	2.5 Nm to 5.0 Nm
	50 mm ²	3.0 Nm to 6.0 Nm
	95 mm ²	6.0 Nm to 12.0 Nm
	150 mm ²	10.0 Nm to 20.0 Nm
For frame sizes FX and GX	-	14.0 Nm to 31.0 Nm
Weight, approx.		
For frame size A	7 kg	
For frame size B	11 kg	
For frame size C	8.5 kg to 29 kg	
For frame size D	21 kg to 34 kg	
For frame size E	49.5 kg to 67 kg	
For frame size F	67 kg to 77.5 kg	
For frame size FX	135 kg	
For frame size GX	138 kg to 208 kg	

Options Variant dependent options

Overview

Line commutating choke

Line commutating chokes are used to smooth voltage peaks or to bridge commutating dips. In addition, line commutating chokes reduce the effects of harmonics on the inverter and the power supply. If the line impedance is $< 1\%$, a line commutating choke must be used in order to reduce the current peaks.

In line with EN 61 000-3-2 regulations "Limits for harmonic currents with device input current ≤ 16 A per phase", there are special aspects for drives with 250 W to 550 W and 230 V single-phase supplies which can be used in non-industrial applications (1st environment).

For devices with 250 W and 350 W, it is necessary either to fit the recommended input chokes or to apply to the power utility company for authorization to connect the devices to the public power supply.

No limits are currently defined in the EN 61 000-3-2 standard for professionally used devices with a connected load > 1 kW which means that the inverters with an output power ≥ 0.75 kW comply with the EN 61 000-3-2 standard.

Output choke

Output chokes can be supplied for reducing the capacitive compensation currents and dV/dt in the case of motor cables > 50 m (shielded) or > 100 m (unshielded).

For max. permissible cable lengths, see the Technical Data.

Brake resistors

The brake resistors are designed for use with the MICROMASTER 440 inverter series, frame sizes A to F, with internal brake chopper and enable loads with a large moment of inertia to be braked quickly. During braking of the motor and the load, excess energy is fed back to the inverter. This causes the voltage to rise in the DC link. The inverter transfers the excess energy to the externally mounted braking resistor.

For MICROMASTER 440 inverters of frame sizes FX and GX, external SIMOVERT MASTERDRIVES brake units and the appropriate brake resistors can be used (see Catalog DA 65.10).

Gland plate

Gland plates are available for inverters of frame sizes A, B and C. In frame sizes D onwards, the gland plates are integrated.

The gland plate enables the shields of the power and control cables to be terminated ensuring optimum EMC performance.

Technical data

Max. permissible cable lengths from the motor to the inverter when using output chokes

The following table shows the maximum permissible cable lengths from the motor to the inverter when using output chokes.

Note:

Operation up to 150 Hz output frequency only!

Frame size (FS)	Output choke Type	Max. permissible motor cable lengths (shielded/unshielded) for a mains voltage of			
		200 V to 240 V $\pm 10\%$	380 V to 400 V $\pm 10\%$	401 V to 480 V $\pm 10\%$	500 V to 600 V $\pm 10\%$
A	6SE6400-3TC00-4AD3	200 m/300 m	–	–	–
A	6SE6400-3TC00-4AD2	200 m/300 m	150 m/225 m	100 m/150 m	–
B	6SE6400-3TC01-0BD3	200 m/300 m	150 m/225 m	100 m/150 m	–
C	6SE6400-3TC03-2CD3	200 m/300 m	200 m/300 m	100 m/150 m	–
C	6SE6400-3TC01-8CE3	–	–	–	100 m/150 m
D to F	6SE6400-3TC.	200 m/300 m	200 m/300 m	200 m/300 m	200 m/300 m
FX	6SL3000-2BE32-1AA0	–	300 m/450 m	300 m/450 m	–
FX	6SL3000-2BE32-6AA0	–	300 m/450 m	300 m/450 m	–
GX	6SL3000-2BE33-2AA0	–	300 m/450 m	300 m/450 m	–
GX	6SL3000-2BE33-8AA0	–	300 m/450 m	300 m/450 m	–
GX	6SL3000-2BE35-0AA0	–	300 m/450 m	300 m/450 m	–

Design

General installation instructions

- A maximum of two footprint components plus inverter are permissible.
- If an LC filter is used, it must, if possible, be mounted directly on the wall of the control cabinet due to weight reasons. If an LC filter of frame size C is used, therefore, only one footprint component is permissible. If a line choke and LC filter are used, the line choke must be located on the left of the inverter. Required spacing: 75 mm.
- The EMC filter must be mounted directly below the frequency inverter if possible.
- If mounted on the side, the line-side components are to be mounted to the left of the frequency inverter whereas the output-side components are to be mounted to the right of the frequency inverter.
- If a braking resistor is used, it must, if possible, be mounted directly on the wall of the control cabinet due to reasons relating to temperature increases.

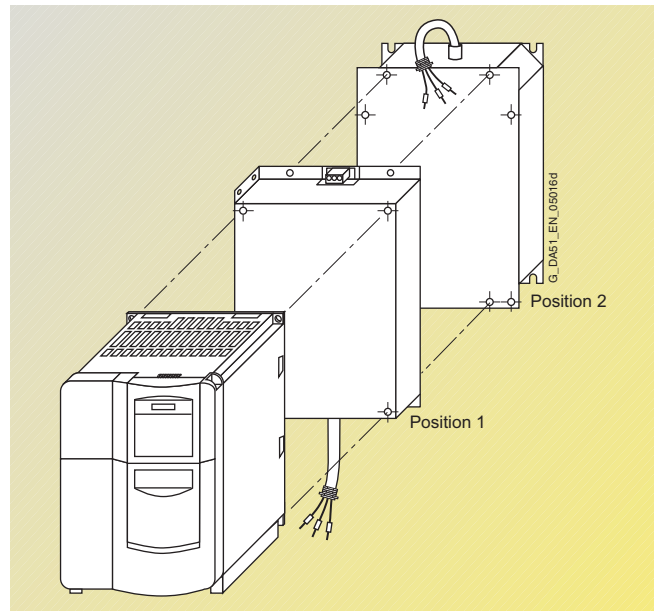

Example of installation with frequency inverter, EMC filter (position 1) and line choke (position 2)

Availability of the options as footprint components

	Frame size									
	A	B	C	D	E	F	G	FX	GX	
Line commutating choke	✓	✓	✓	✓	✓					
EMC filter	✓	✓	✓							
LC filter	✓	✓	✓							
Output choke	✓	✓								
Braking resistor	✓	✓								

Recommended combinations of inverters and options



Frequency inverter Frame size	Footprint		Mounted on side	
	Position 1	Position 2	To the left of the inverter (for line-side components)	To the right of the inverter (for output-side components)
A and B	EMC filter	Line commutating choke	–	Output choke <u>and/or</u> Braking resistor
	EMC filter <u>or</u> Line commutating choke	Output choke <u>or</u> LC filter	–	Braking resistor
	EMC filter <u>or</u> Line commutating choke	Braking resistor	–	–
	EMC filter <u>or</u> Line commutating choke <u>or</u> Braking resistor	–	–	–
C	EMC filter	Line commutating choke	–	Output choke <u>and/or</u> Braking resistor
	EMC filter <u>or</u> Line commutating choke	Output choke	–	Braking resistor
	LC filter	–	EMC filter <u>and/or</u> Line commutating choke	Braking resistor
D and E	Line commutating choke	–	EMC filter	Output choke <u>or</u> LC filter <u>and/or</u> Braking resistor
F, G, FX and GX	–	–	EMC filter <u>and/or</u> Line commutating choke	Output choke <u>or</u> LC filter <u>and/or</u> Braking resistor

Options Variant dependent options

Selection and ordering data

The options listed here (filters, chokes, brake resistors, gland plates, fuses and circuit-breakers) must be selected to match the respective inverter.

The inverter and the associated options have the same voltage ratings.

All options are certified to , except fuses. The 3NE1 fuses are -listed (equivalent to ).

*) Must be used in combination with a line commutating choke.

Mains voltage	Output		Inverter without filter	Order No. of the options		
	kW	hp		EMC filter, Class A	EMC filter, Class B	Line commutating choke
1 AC 200 V to 240 V	0.12	0.16	6SE6440-2UC11-2AA1	–	6SE6400-2FL01-0AB0	6SE6400-3CC00-4AB3
	0.25	0.33	6SE6440-2UC12-5AA1	–	with low leakage currents	
	0.37	0.50	6SE6440-2UC13-7AA1	–		6SE6400-3CC01-0AB3
	0.55	0.75	6SE6440-2UC15-5AA1	–		
	0.75	1.0	6SE6440-2UC17-5AA1	–		
	1.1	1.5	6SE6440-2UC21-1BA1	–	6SE6400-2FL02-6BB0	6SE6400-3CC02-6BB3
	1.5	2.0	6SE6440-2UC21-5BA1	–	with low leakage currents	
	2.2	3.0	6SE6440-2UC22-2BA1	–		
	3.0	4.0	6SE6440-2UC23-0CA1	–	–	6SE6400-3CC03-5CB3
	3 AC 200 V to 240 V	0.12	0.16	6SE6440-2UC11-2AA1	6SE6400-2FA00-6AD0	6SE6400-2FB00-6AD0
0.25		0.33	6SE6440-2UC12-5AA1	–	–	
0.37		0.50	6SE6440-2UC13-7AA1	–	–	6SE6400-3CC00-5AC3
0.55		0.75	6SE6440-2UC15-5AA1	–	–	
0.75		1.0	6SE6440-2UC17-5AA1	–	–	
1.1		1.5	6SE6440-2UC21-1BA1	6SE6400-2FA01-4BC0	6SE6400-2FB01-4BC0	6SE6400-3CC00-8BC3
1.5		2.0	6SE6440-2UC21-5BA1	–	–	6SE6400-3CC01-4BD3
2.2		3.0	6SE6440-2UC22-2BA1	–	–	
3.0		4.0	6SE6440-2UC23-0CA1	–	–	6SE6400-3CC01-7CC3
4.0		5.0	6SE6440-2UC24-0CA1	–	–	6SE6400-3CC03-5CD3
5.5		7.5	6SE6440-2UC25-5CA1	–	–	
7.5		10	6SE6440-2UC27-5DA1	–	–	6SE6400-3CC05-2DD0
11.0		15	6SE6440-2UC31-1DA1	–	–	
15.0		20	6SE6440-2UC31-5DA1	–	–	
18.5		25	6SE6440-2UC31-8EA1	–	–	6SE6400-3CC08-8EC0
22		30	6SE6440-2UC32-2EA1	–	–	
30		40	6SE6440-2UC33-0FA1	–	–	6SE6400-3CC11-7FD0
37		50	6SE6440-2UC33-7FA1	–	–	
45	60	6SE6440-2UC34-5FA1	–	–		
3 AC 380 V to 480 V	0.37	0.50	6SE6440-2UD13-7AA1	6SE6400-2FA00-6AD0	6SE6400-2FB00-6AD0	6SE6400-3CC00-2AD3
	0.55	0.75	6SE6440-2UD15-5AA1	–	–	
	0.75	1.0	6SE6440-2UD17-5AA1	–	–	6SE6400-3CC00-4AD3
	1.1	1.5	6SE6440-2UD21-1AA1	–	–	
	1.5	2.0	6SE6440-2UD21-5AA1	–	–	6SE6400-3CC00-6AD3
	2.2	3.0	6SE6440-2UD22-2BA1	–	–	6SE6400-3CC01-0BD3
	3.0	4.0	6SE6440-2UD23-0BA1	–	–	
	4.0	5.0	6SE6440-2UD24-0BA1	–	–	6SE6400-3CC01-4BD3
	5.5	7.5	6SE6440-2UD25-5CA1	–	–	6SE6400-3CC02-2CD3
	7.5	10	6SE6440-2UD27-5CA1	–	–	
	11.0	15	6SE6440-2UD31-1CA1	–	–	6SE6400-3CC03-5CD3
	15.0	20	6SE6440-2UD31-5DA1	–	EMC filter, Class B, available from Schaffner	6SE6400-3CC04-4DD0
	18.5	25	6SE6440-2UD31-8DA1	–	–	
	22	30	6SE6440-2UD32-2DA1	–	–	6SE6400-3CC05-2DD0
	30	40	6SE6440-2UD33-0EA1	–	–	6SE6400-3CC08-3ED0
	37	50	6SE6440-2UD33-7EA1	–	–	
	45	60	6SE6440-2UD34-5FA1	–	–	6SE6400-3CC11-2FD0
	55	75	6SE6440-2UD35-5FA1	–	–	
75	100	6SE6440-2UD37-5FA1	–	–	6SE6400-3CC11-7FD0	
90	125	6SE6440-2UD38-8FA1	6SL3000-0BE32-5AA0 *)	–	6SL3000-0CE32-3AA0	
110	150	6SE6440-2UD41-1FA1	6SL3000-0BE34-4AA0 *)	–	6SL3000-0CE32-8AA0	
132	200	6SE6440-2UD41-3GA1	–	–	6SL3000-0CE33-3AA0	
160	250	6SE6440-2UD41-6GA1	–	–	6SL3000-0CE35-1AA0	
200	300	6SE6440-2UD42-0GA1	6SL3000-0BE36-0AA0 *)	–		
3 AC 500 V to 600 V	0.75	1.0	6SE6440-2UE17-5CA1	–	–	6SE6400-3CC00-4CE3
	1.5	2.0	6SE6440-2UE21-5CA1	–	–	
	2.2	3.0	6SE6440-2UE22-2CA1	–	–	6SE6400-3CC00-8CE3
	4.0	5.0	6SE6440-2UE24-0CA1	–	–	
	5.5	7.5	6SE6440-2UE25-5CA1	–	–	6SE6400-3CC02-4CE3
	7.5	10	6SE6440-2UE27-5CA1	–	–	
	11.0	15	6SE6440-2UE31-1CA1	–	–	
	15.0	20	6SE6440-2UE31-5DA1	–	–	6SE6400-3CC04-4DD0
	18.5	25	6SE6440-2UE31-8DA1	–	–	
	22	30	6SE6440-2UE32-2DA1	–	–	
	30	40	6SE6440-2UE33-0EA1	–	–	6SE6400-3CC08-3ED0
	37	50	6SE6440-2UE33-7EA1	–	–	
	45	60	6SE6440-2UE34-5FA1	–	–	6SE6400-3CC11-2FD0
	55	75	6SE6440-2UE35-5FA1	–	–	
75	100	6SE6440-2UE37-5FA1	–	–		

Selection and ordering data (continued)

Mains voltage	Output		Inverter without filter	Order No. of the options LC/sinusoidal filter	Output choke	Brake resistors
	kW	hp				
1 AC 200 V to 240 V	0.12	0.16	6SE6440-2UC11-2AA1	–	6SE6400-3TC00-4AD3	6SE6400-4BC05-0AA0
	0.25	0.33	6SE6440-2UC12-5AA1	–		
	0.37	0.50	6SE6440-2UC13-7AA1	–		
	0.55	0.75	6SE6440-2UC15-5AA1	–		
	0.75	1.0	6SE6440-2UC17-5AA1	–		
	1.1	1.5	6SE6440-2UC21-1BA1	–		
	1.5	2.0	6SE6440-2UC21-5BA1	–		
	2.2	3.0	6SE6440-2UC22-2BA1	–		
	3.0	4.0	6SE6440-2UC23-0CA1	–		
3 AC 200 V to 240 V	0.12	0.16	6SE6440-2UC11-2AA1	–	6SE6400-3TC03-2CD3	6SE6400-4BC12-5CA0
	0.25	0.33	6SE6440-2UC12-5AA1	–		
	0.37	0.50	6SE6440-2UC13-7AA1	–		
	0.55	0.75	6SE6440-2UC15-5AA1	–		
	0.75	1.0	6SE6440-2UC17-5AA1	–		
	1.1	1.5	6SE6440-2UC21-1BA1	–		
	1.5	2.0	6SE6440-2UC21-5BA1	–		
	2.2	3.0	6SE6440-2UC22-2BA1	–		
	3.0	4.0	6SE6440-2UC23-0CA1	–		
	4.0	5.0	6SE6440-2UC24-0CA1	–		
	5.5	7.5	6SE6440-2UC25-5CA1	–		
	7.5	10	6SE6440-2UC27-5DA1	–		
	11.0	15	6SE6440-2UC31-1DA1	–		
	15.0	20	6SE6440-2UC31-5DA1	–		
	18.5	25	6SE6440-2UC31-8EA1	–		
	22	30	6SE6440-2UC32-2EA1	–		
	30	40	6SE6440-2UC33-0FA1	–		
	37	50	6SE6440-2UC33-7FA1	–		
	45	60	6SE6440-2UC34-5FA1	–		
3 AC 380 V to 480 V	0.37	0.50	6SE6440-2UD13-7AA1	6SE6400-3TD00-4AD0	6SE6400-3TC00-4AD2	6SE6400-4BD11-0AA0
	0.55	0.75	6SE6440-2UD15-5AA1	–		
	0.75	1.0	6SE6440-2UD17-5AA1	–		
	1.1	1.5	6SE6440-2UD21-1AA1	–		
	1.5	2.0	6SE6440-2UD21-5AA1	–		
	2.2	3.0	6SE6440-2UD22-2BA1	6SE6400-3TD01-0BD0		
	3.0	4.0	6SE6440-2UD23-0BA1	–		
	4.0	5.0	6SE6440-2UD24-0BA1	–		
	5.5	7.5	6SE6440-2UD25-5CA1	6SE6400-3TD03-2CD0		
	7.5	10	6SE6440-2UD27-5CA1	–		
	11.0	15	6SE6440-2UD31-1CA1	–		
	15.0	20	6SE6440-2UD31-5DA1	6SE6400-3TD03-7DD0		
	18.5	25	6SE6440-2UD31-8DA1	6SE6400-3TD04-8DD0		
	22	30	6SE6440-2UD32-2DA1	6SE6400-3TD06-1DD0		
	30	40	6SE6440-2UD33-0EA1	6SE6400-3TD07-2ED0		
	37	50	6SE6440-2UD33-7EA1	6SE6400-3TD11-5FD0		
	45	60	6SE6440-2UD34-5FA1	–		
	55	75	6SE6440-2UD35-5FA1	6SE6400-3TD15-0FD0		
	75	100	6SE6440-2UD37-5FA1	6SE6400-3TD18-0FD0		
	90	125	6SE6440-2UD38-8FA1	6SL3000-2CE32-3AA0		
110	150	6SE6440-2UD41-1FA1	–			
132	200	6SE6440-2UD41-3GA1	6SL3000-2CE32-8AA0			
160	250	6SE6440-2UD41-6GA1	6SL3000-2CE33-3AA0			
200	300	6SE6440-2UD42-0GA1	6SL3000-2CE34-1AA0			
3 AC 500 V to 600 V	0.75	1.0	6SE6440-2UE17-5CA1	6SE6400-3TD01-0CE0	6SE6400-3TC01-8CE3	6SE6400-4BE14-5CA0
	1.5	2.0	6SE6440-2UE21-5CA1	–		
	2.2	3.0	6SE6440-2UE22-2CA1	–		
	4.0	5.0	6SE6440-2UE24-0CA1	–		
	5.5	7.5	6SE6440-2UE25-5CA1	6SE6400-3TD02-3CE0		
	7.5	10	6SE6440-2UE27-5CA1	–		
	11.0	15	6SE6440-2UE31-1CA1	–		
	15.0	20	6SE6440-2UE31-5DA1	6SE6400-3TD02-3DE0		
	18.5	25	6SE6440-2UE31-8DA1	6SE6400-3TD03-2DE0		
	22	30	6SE6440-2UE32-2DA1	6SE6400-3TD03-7DE0		
	30	40	6SE6440-2UE33-0EA1	6SE6400-3TD04-8EE0		
	37	50	6SE6440-2UE33-7EA1	6SE6400-3TD06-1EE0		
	45	60	6SE6440-2UE34-5FA1	6SE6400-3TD07-1FE0		
	55	75	6SE6440-2UE35-5FA1	6SE6400-3TD10-0FE0		
75	100	6SE6440-2UE37-5FA1	6SE6400-3TD11-5FE0			

Options Variant dependent options

Selection and ordering data (continued)

● Use in America requires
Ⓢ-listed fuses such as
the Class NON range
from Bussmann.

Mains voltage	Output		Inverter without filter	Order No. of options Gland plate	Fuses (see LV 10)		Circuit-breaker (see Catalog LV 10)	
	kW	hp			3NA3	3NE1 (Ⓢ)		
1 AC 200 V to 240 V	0.12	0.16	6SE6440-2UC11-2AA1	6SE6400-0GP00-0AA0	3NA3803	●	3RV1021-1EA10	
	0.25	0.33	6SE6440-2UC12-5AA1				3RV1021-1HA10	
	0.37	0.50	6SE6440-2UC13-7AA1				3RV1021-1JA10	
	0.55	0.75	6SE6440-2UC15-5AA1		3NA3805		3RV1021-1KA10	
	0.75	1.0	6SE6440-2UC17-5AA1				3RV1021-4AA10	
	1.1	1.5	6SE6440-2UC21-1BA1	6SE6400-0GP00-0BA0	3NA3807		3RV1021-4DA10	
	1.5	2.0	6SE6440-2UC21-5BA1			3RV1031-4EA10		
	2.2	3.0	6SE6440-2UC22-2BA1			3RV1031-4FA10		
	3.0	4.0	6SE6440-2UC23-0CA1	6SE6400-0GP00-0CA0	3NA3817		3RV1041-4JA10	
	3 AC 200 V to 240 V	0.12	0.16	6SE6440-2UC11-2AA1	6SE6400-0GP00-0AA0	3NA3803	●	3RV1021-1BA10
		0.25	0.33	6SE6440-2UC12-5AA1				3RV1021-1DA10
0.37		0.50	6SE6440-2UC13-7AA1	3RV1021-1FA10				
0.55		0.75	6SE6440-2UC15-5AA1		3NA3805		3RV1021-1GA10	
0.75		1.0	6SE6440-2UC17-5AA1				3RV1021-1HA10	
1.1		1.5	6SE6440-2UC21-1BA1	6SE6400-0GP00-0BA0	3NA3807		3RV1021-1KA10	
1.5		2.0	6SE6440-2UC21-5BA1			3RV1021-4AA10		
2.2		3.0	6SE6440-2UC22-2BA1			3RV1021-4CA10		
3.0		4.0	6SE6440-2UC23-0CA1	6SE6400-0GP00-0CA0	3NA3810		3RV1021-4FA10	
4.0		5.0	6SE6440-2UC24-0CA1		3NA3812		3RV1031-4FA10	
5.5		7.5	6SE6440-2UC25-5CA1		3NA3814		3RV1031-4HA10	
7.5		10	6SE6440-2UC27-5DA1	Integrated as standard	3NA3820	3NE1817-0	3RV1042-4JA10	
11.0		15	6SE6440-2UC31-1DA1		3NA3824	3NE1820-0	3RV1042-4LA10	
15.0		20	6SE6440-2UC31-5DA1				3VL1712-. DD33-....	
18.5		25	6SE6440-2UC31-8EA1		3NA3830	3NE1021-0		
22		30	6SE6440-2UC32-2EA1		3NA3832	3NE1022-0	3VL1716-. DD33-....	
30		40	6SE6440-2UC33-0FA1		3NA3140	3NE1225-0	3VL3725-. DC36-....	
37		50	6SE6440-2UC33-7FA1		3NA3142	3NE1225-0	3VL4731-. DC36-....	
45		60	6SE6440-2UC34-5FA1		3NA3144	3NE1227-0		
3 AC 380 V to 480 V	0.37	0.50	6SE6440-2UD13-7AA1	6SE6400-0GP00-0AA0	3NA3803	●	3RV1021-1CA10	
	0.55	0.75	6SE6440-2UD15-5AA1				3RV1021-1DA10	
	0.75	1.0	6SE6440-2UD17-5AA1				3RV1021-1FA10	
	1.1	1.5	6SE6440-2UD21-1AA1				3RV1021-1GA10	
	1.5	2.0	6SE6440-2UD21-5AA1				3RV1021-1JA10	
	2.2	3.0	6SE6440-2UD22-2BA1	6SE6400-0GP00-0BA0	3NA3805		3RV1021-1KA10	
	3.0	4.0	6SE6440-2UD23-0BA1			3RV1021-4AA10		
	4.0	5.0	6SE6440-2UD24-0BA1			3RV1021-4BA10		
	5.5	7.5	6SE6440-2UD25-5CA1	6SE6400-0GP00-0CA0	3NA3807		3RV1031-4EA10	
	7.5	10	6SE6440-2UD27-5CA1		3NA3812		3RV1031-4FA10	
	11.0	15	6SE6440-2UD31-1CA1		3NA3814		3RV1031-4HA10	
	15.0	20	6SE6440-2UD31-5DA1	Integrated as standard	3NA3820	3NE1817-0	3RV1042-4KA10	
	18.5	25	6SE6440-2UD31-8DA1		3NA3822	3NE1818-0		
	22	30	6SE6440-2UD32-2DA1		3NA3824	3NE1820-0	3RV1042-4MA10	
	30	40	6SE6440-2UD33-0EA1		3NA3830	3NE1021-0	3VL1712-. DD33-....	
	37	50	6SE6440-2UD33-7EA1		3NA3832	3NE1022-0	3VL1716-. DD33-....	
	45	60	6SE6440-2UD34-5FA1		3NA3836	3NE1224-0	3VL3720-. DC36-....	
	55	75	6SE6440-2UD35-5FA1		3NA3140	3NE1225-0	3VL3725-. DC36-....	
	75	100	6SE6440-2UD37-5FA1		3NA3144	3NE1227-0	3VL4731-. DC36-....	
90	125	6SE6440-2UD38-8FA1	-	-	-	3VL3725-. DC36-....		
110	150	6SE6440-2UD41-1FA1	-	-	3NE1230-0	3VL4731-. DC36-....		
132	200	6SE6440-2UD41-3GA1	-	-	3NE1332-0			
160	250	6SE6440-2UD41-6GA1	-	-	3NE1333-0	3VL4740-. DC36-....		
200	300	6SE6440-2UD42-0GA1	-	-	3NE1435-0	3VL5750-. DC36-....		
3 AC 500 V to 600 V	0.75	1.0	6SE6440-2UE17-5CA1	6SE6400-0GP00-0CA0	3NA3803-6	●	3RV1021-1EA10	
	1.5	2.0	6SE6440-2UE21-5CA1				3RV1021-1GA10	
	2.2	3.0	6SE6440-2UE22-2CA1				3RV1021-1JA10	
	4.0	5.0	6SE6440-2UE24-0CA1		3NA3805-6		3RV1021-4AA10	
	5.5	7.5	6SE6440-2UE25-5CA1				3RV1021-4BA10	
	7.5	10	6SE6440-2UE27-5CA1		3NA3810-6		3RV1021-4DA10	
	11.0	15	6SE6440-2UE31-1CA1		3NA3812-6		3RV1031-4FA10	
	15.0	20	6SE6440-2UE31-5DA1	Integrated as standard	3NA3814-6	3NE1803-0	3RV1031-4HA10	
	18.5	25	6SE6440-2UE31-8DA1		3NA3820-6	3NE1817-0	3RV1042-4JA10	
	22	30	6SE6440-2UE32-2DA1		3NA3822-6	3NE1818-0	3RV1042-4KA10	
	30	40	6SE6440-2UE33-0EA1		3NA3824-6	3NE1820-0	3RV1042-4MA10	
	37	50	6SE6440-2UE33-7EA1				3VL1712-. DD33-....	
	45	60	6SE6440-2UE34-5FA1		3NA3132-6	3NE1022-0	3VL1716-. DD33-....	
	55	75	6SE6440-2UE35-5FA1		3NA3136-6	3NE1224-0	3VL3720-. DC36-....	
	75	100	6SE6440-2UE37-5FA1				3VL3725-. DC36-....	

Selection and ordering data (continued)

Mains voltage	Output		Inverter with internal filter Class A	Order No. of options Additional EMC filter, Class B	Line commutating choke	LC filter
	kW	hp				
1 AC 200 V to 240 V	0.12	0.16	6SE6440-2AB11-2AA1	6SE6400-2FS01-0AB0	6SE6400-3CC00-4AB3	–
	0.25	0.33	6SE6440-2AB12-5AA1			–
	0.37	0.50	6SE6440-2AB13-7AA1			6SE6400-3CC01-0AB3
	0.55	0.75	6SE6440-2AB15-5AA1	–	–	–
	0.75	1.0	6SE6440-2AB17-5AA1	–	–	–
	1.1	1.5	6SE6440-2AB21-1BA1	6SE6400-2FS02-6BB0	6SE6400-3CC02-6BB3	–
	1.5	2.0	6SE6440-2AB21-5BA1			–
	2.2	3.0	6SE6440-2AB22-2BA1	–	–	–
	3.0	4.0	6SE6440-2AB23-0CA1	6SE6400-2FS03-5CB0	6SE6400-3CC03-5CB3	–
	3.0	4.0	6SE6440-2AC23-0CA1			6SE6400-2FS03-8CD0
3 AC 200 V to 240 V	4.0	5.0	6SE6440-2AC24-0CA1	–	6SE6400-3CC03-5CD3	–
	5.5	7.5	6SE6440-2AC25-5CA1	–	–	–
	2.2	3.0	6SE6440-2AD22-2BA1	6SE6400-2FS01-6BD0	6SE6400-3CC01-0BD3	6SE6400-3TD01-0BD0
3.0	4.0	6SE6440-2AD23-0BA1	–			
3 AC 380 V to 480 V	4.0	5.0	6SE6440-2AD24-0BA1	–	6SE6400-3CC01-4BD3	–
	5.5	7.5	6SE6440-2AD25-5CA1	6SE6400-2FS03-8CD0	6SE6400-3CC02-2CD3	6SE6400-3TD03-2CD0
	7.5	10	6SE6440-2AD27-5CA1			
	11.0	15	6SE6440-2AD31-1CA1	–	6SE6400-3CC03-5CD3	–
	15.0	20	6SE6440-2AD31-5DA1	An inverter without filter must be selected to satisfy the EMC requirements of Class B. In addition, an appropriate EMC filter of Class B from Schaffner is required.	6SE6400-3CC04-4DD0	6SE6400-3TD03-7DD0
	18.5	25	6SE6440-2AD31-8DA1		6SE6400-3TD04-8DD0	
	22	30	6SE6440-2AD32-2DA1		6SE6400-3CC05-2DD0	6SE6400-3TD06-1DD0
	30	40	6SE6440-2AD33-0EA1		6SE6400-3CC08-3ED0	6SE6400-3TD07-2ED0
	37	50	6SE6440-2AD33-7EA1		–	6SE6400-3TD11-5FD0
	45	60	6SE6440-2AD34-5FA1		6SE6400-3CC11-2FD0	–
	55	75	6SE6440-2AD35-5FA1		–	6SE6400-3TD15-0FD0
	75	100	6SE6440-2AD37-5FA1		6SE6400-3CC11-7FD0	6SE6400-3TD18-0FD0

Mains voltage	Output		Inverter with internal filter Class A	Order No. of options Output choke	Brake resistors	Gland plate	
	kW	hp					
1 AC 200 V to 240 V	0.12	0.16	6SE6440-2AB11-2AA1	6SE6400-3TC00-4AD3	6SE6400-4BC05-0AA0	6SE6400-0GP00-0AA0	
	0.25	0.33	6SE6440-2AB12-5AA1				–
	0.37	0.50	6SE6440-2AB13-7AA1				–
	0.55	0.75	6SE6440-2AB15-5AA1	–	–	–	
	0.75	1.0	6SE6440-2AB17-5AA1	–	–	–	
	1.1	1.5	6SE6440-2AB21-1BA1	6SE6400-3TC01-0BD3	6SE6400-4BC11-2BA0	6SE6400-0GP00-0BA0	
	1.5	2.0	6SE6440-2AB21-5BA1				–
	2.2	3.0	6SE6440-2AB22-2BA1	–	–	–	
	3.0	4.0	6SE6440-2AB23-0CA1	6SE6400-3TC03-2CD3	6SE6400-4BC12-5CA0	6SE6400-0GP00-0CA0	
	3.0	4.0	6SE6440-2AC23-0CA1				6SE6400-3TC03-2CD3
3 AC 200 V to 240 V	4.0	5.0	6SE6440-2AC24-0CA1	–	6SE6400-4BC13-0CA0	–	
	5.5	7.5	6SE6440-2AC25-5CA1	–	–	–	
	2.2	3.0	6SE6440-2AD22-2BA1	6SE6400-3TC01-0BD3	6SE6400-4BD12-0BA0	6SE6400-0GP00-0BA0	
3.0	4.0	6SE6440-2AD23-0BA1	–				
3 AC 380 V to 480 V	4.0	5.0	6SE6440-2AD24-0BA1	–	–	–	
	5.5	7.5	6SE6440-2AD25-5CA1	6SE6400-3TC03-2CD3	6SE6400-4BD16-5CA0	6SE6400-0GP00-0CA0	
	7.5	10	6SE6440-2AD27-5CA1				–
	11.0	15	6SE6440-2AD31-1CA1	–	–	–	
	15.0	20	6SE6440-2AD31-5DA1	6SE6400-3TC05-4DD0	6SE6400-4BD21-2DA0	Integrated as standard	
	18.5	25	6SE6440-2AD31-8DA1	6SE6400-3TC03-8DD0	–	–	
	22	30	6SE6440-2AD32-2DA1	6SE6400-3TC05-4DD0	–	–	
	30	40	6SE6440-2AD33-0EA1	6SE6400-3TC08-0ED0	6SE6400-4BD22-2EA0	–	
	37	50	6SE6440-2AD33-7EA1	6SE6400-3TC07-5ED0	–	–	
	45	60	6SE6440-2AD34-5FA1	6SE6400-3TC14-5FD0	6SE6400-4BD24-0FA0	–	
	55	75	6SE6440-2AD35-5FA1	6SE6400-3TC15-4FD0	–	–	
	75	100	6SE6440-2AD37-5FA1	6SE6400-3TC14-5FD0	–	–	

MICROMASTER 440

Options Variant dependent options

Selection and ordering data (continued)

Mains voltage	Output		Inverter with internal filter Class A	Order No. of the options		Circuit-breaker (see Catalog LV 10)
	kW	hp		Fuses (see Catalog LV 10) 3NA3	3NE1 (9A)	
1 AC 200 V to 240 V	0.12	0.16	6SE6440-2AB11-2AA1	3NA3803	●	3RV1021-1EA10
	0.25	0.33	6SE6440-2AB12-5AA1			3RV1021-1HA10
	0.37	0.50	6SE6440-2AB13-7AA1			3RV1021-1JA10
	0.55	0.75	6SE6440-2AB15-5AA1	3NA3805		3RV1021-1KA10
	0.75	1.0	6SE6440-2AB17-5AA1			3RV1021-4AA10
	1.1	1.5	6SE6440-2AB21-1BA1	3NA3807		3RV1021-4DA10
	1.5	2.0	6SE6440-2AB21-5BA1			3RV1031-4EA10
	2.2	3.0	6SE6440-2AB22-2BA1	3NA3812		3RV1031-4FA10
	3.0	4.0	6SE6440-2AB23-0CA1	3NA3817		3RV1041-4JA10
3 AC 200 V to 240 V	3.0	4.0	6SE6440-2AC23-0CA1	3NA3810	●	3RV1031-4EA10
	4.0	5.0	6SE6440-2AC24-0CA1	3NA3812		3RV1031-4FA10
	5.5	7.5	6SE6440-2AC25-5CA1	3NA3814		3RV1031-4HA10
3 AC 380 V to 480 V	2.2	3.0	6SE6440-2AD22-2BA1	3NA3805	●	3RV1021-1KA10
	3.0	4.0	6SE6440-2AD23-0BA1			3RV1021-4AA10
	4.0	5.0	6SE6440-2AD24-0BA1	3NA3807		3RV1021-4BA10
	5.5	7.5	6SE6440-2AD25-5CA1			3RV1031-4EA10
	7.5	10	6SE6440-2AD27-5CA1	3NA3812		3RV1031-4FA10
	11.0	15	6SE6440-2AD31-1CA1	3NA3814		3RV1031-4HA10
	15.0	20	6SE6440-2AD31-5DA1	3NA3820	3NE1817-0	3RV1042-4KA10
	18.5	25	6SE6440-2AD31-8DA1	3NA3822	3NE1818-0	
	22	30	6SE6440-2AD32-2DA1	3NA3824	3NE1820-0	3RV1042-4MA10
	30	40	6SE6440-2AD33-0EA1	3NA3830	3NE1021-0	3VL1712- . DD33-
	37	50	6SE6440-2AD33-7EA1	3NA3832	3NE1022-0	3VL1716- . DD33-
	45	60	6SE6440-2AD34-5FA1	3NA3836	3NE1224-0	3VL3720- . DC36-
55	75	6SE6440-2AD35-5FA1	3NA3140	3NE1225-0	3VL3725- . DC36-	
75	100	6SE6440-2AD37-5FA1	3NA3144	3NE1227-0	3VL4731- . DC36-	

● Use in America requires
Ⓢ-listed fuses such as the
Class NON range from
Bussmann.

Overview

Basic Operator Panel (BOP)

With the BOP, individual parameter settings can be made. Values and units are shown on a 5-digit display.



Basic Operator Panel (BOP)

A BOP can be used for several inverters. It can be directly mounted on the inverter or in a control cabinet door using a mounting kit.

Advanced Operator Panel (AOP)

The AOP enables MICROMASTER 440 parameter kits to be easily read and modified. In contrast to the BOP, the value and meaning of the parameters can be directly displayed as plain text in several languages by fast scrolling of the address.



Advanced Operator Panel (AOP)

The AOP is directly plugged into the inverter, or communicates with the latter through a door mounting kit. Together with the "AOP door mounting kit for multiple inverters", the AOP permits bus communication with up to 30 inverters at a transmission rate of 38 kbaud. (RS485, USS).

For servicing purposes, the AOP furthermore supports the download and upload of complete parameter kits.

Asian Advanced Operator Panel (AAOP)

The AAOP is the Chinese version of the AOP operator panel. It has an enhanced display and supports the operating languages of Chinese (simplified) and English.



Asian Advanced Operator Panel (AAOP)

PROFIBUS module

For a complete PROFIBUS connection with up to ≤ 12 Mbaud. Remote control of the inverter is possible with the PROFIBUS module. Remote control and operation at the inverter can be combined using an operator panel plugged onto the PROFIBUS module. The PROFIBUS module can be supplied by an external 24 V DC power supply and is thus also active when the inverter is disconnected from the power supply.

Connection by means of a 9-pin Sub-D connector (available as an option).

DeviceNet module

For networking the inverters to the DeviceNet fieldbus system widely used on the American market. A maximum transmission rate of 500 kbaud is possible. Remote control of the inverter is possible with the DeviceNet module. Remote control and operation at the inverter can be combined using an operator panel plugged onto the DeviceNet module.

The connection to the DeviceNet bus system is made using a 5-pin connector with terminal strip.

CANopen module

Using the CANopen communications module, an inverter can be linked to the CANopen fieldbus system and remote control is then possible.

Remote control and operation at the inverter can be combined using an operator panel plugged onto the CANopen module.

The module is connected to the bus system through a 9-pin Sub-D connector.

Pulse encoder evaluation module

The pulse encoder evaluation module permits direct connection of the most widely encountered digital pulse encoders to the inverter.

They offer the following functions:

- Zero speed at full load torque
- Extremely accurate speed control
- Increased dynamic response of speed and torque control.

This module can be used with HTL and TTL pulse encoders (High voltage Transistor Logic, 24 V and Transistor Logic, 5 V).

Options

Variant independent options

Overview (continued)

Connection kit for PC to inverter

For controlling an inverter directly from a PC if the appropriate software has been installed (e.g. STARTER). Isolated RS-232 adapter module for reliable point-to-point connection to a PC. Includes a Sub-D connector and an RS-232 standard cable (3 m).

Connection kit for PC to AOP

For connecting a PC to an AOP or AAOP. Offline programming of inverters and archiving of parameter kits possible. Includes a desktop attachment kit for an AOP or AAOP, an RS-232 standard cable (3 m) with Sub-D connectors and a universal power supply unit.

Operator panel door mounting kit for single inverter

For mounting an operator panel in a control cabinet door. Degree of protection IP56. Contains a cable adapter module with screwless terminals for use with user's own RS-232 cables ¹⁾.

AOP door mounting kit for multiple inverters (USS)

For mounting an AOP or AAOP in a control cabinet door. Degree of protection IP56. The AOP or AAOP can communicate with several inverters by means of the RS-485 USS protocol. The 4-pin connecting cable from the AOP or AAOP to the RS-485 terminals of the inverter and to the 24 V user terminal strip is not included ²⁾.

Start-up tools

- **STARTER**
Starter is graphic start-up software for guided start-up for MICROMASTER 410/420/430/440 frequency inverters under Windows NT/2000/XP Professional. Parameter lists can be read out, altered, stored, entered and printed.
- **DriveMonitor**
is a start-up software for list-oriented programming of frequency inverters. This program executes under Windows 98/NT/2000/ME/XP Professional.

Both programs are included on the Docu CD which is provided with every inverter.

Selection and ordering data

The options listed here are suitable for all MICROMASTER 440 inverters.



Options	Order No.
Basic Operator Panel (BOP)	6SE6400-0BP00-0AA0
Advanced Operator Panel (AOP)	6SE6400-0AP00-0AA1
Asian Advanced Operator Panel (AAOP)	6SE6400-0AP00-0AB0
PROFIBUS module	6SE6400-1PB00-0AA0
DeviceNet module	6SE6400-1DN00-0AA0
CANopen module	6SE6400-1CB00-0AA0
Pulse encoder evaluation module	6SE6400-0EN00-0AA0
RS485/PROFIBUS bus connector	6GK1500-0FC00
Connection kit for PC to inverter	6SE6400-1PC00-0AA0
Connection kit for PC to AOP	6SE6400-0PA00-0AA0
Operator panel door mounting kit for single inverter	6SE6400-0PM00-0AA0
AOP door mounting kit for multiple inverters (USS)	6SE6400-0MD00-0AA0
Start-up tool STARTER on CD-ROM	6SL3072-0AA00-0AG0

Available on the Internet at:
<http://www4.ad.siemens.de/WWW/view/com/10804985/133100>

1) A shielded cable of type Belden 8132 (28 AWG) is recommended. The maximum cable length is 5 m for RS-232.



2) A shielded cable of type Belden 8132 (28 AWG) is recommended. The maximum cable length is 10 m for RS-485.

Technical data

		PROFIBUS module 6SE6400-1PB00-0AA0	DeviceNet module 6SE6400-1DN00-0AA0
			
Size (height x width x depth)		161 mm x 73 mm x 46 mm	
Degree of protection		IP20	
Degree of pollution		2 to IEC 60664-1 (DIN VDE 0110/T1), no condensation permitted during operation	
Strain resistance		to IEC 60068-2-6 (if module is installed correctly)	
• Stationary	Deflection	0.15 mm in the frequency range of 10 Hz to 58 Hz	
	Acceleration	19.6 m/s ² in the frequency range of 58 Hz to 500 Hz	
• Transport	Deflection	3.5 mm in the frequency range of 5 Hz to 9 Hz	
	Acceleration	9.8 m/s ² in the frequency range of 9 Hz to 500 Hz	
Climatic category (during operation)		3K3 to IEC 60721-3-3	
Cooling method		Natural air cooling	
Permissible ambient or cooling agent temperature			
• Operation		-10 °C to +50 °C (+14 °F to +122 °F)	
• Storage and transport		-25 °C to +70 °C (-13 °F to +158 °F)	
Relative humidity (permissible humidity rating)			
• Operation		≤ 85 % (non-condensing)	
• Storage and transport		≤ 95 %	
Electromagnetic compatibility		Emission	to EN 55011 (1991) Class A
		Interference	to IEC 60801-3 and EN 61000-4-3
Power supply		6.5 V ± 5 %, max. 300 mA, internal from inverter or 24 V ± 10 %, max. 350 mA, external	6.5 V ± 5 %, max. 300 mA internal from inverter or 24 V, max. 60 mA from DeviceNet-Bus
Output voltage		5 V ± 10 %, max. 100 mA, galvanically isolated supply • for terminating the serial interface bus or • for supplying the OLP (Optical Link Plug)	-
Data transmission rate		max. 12 Mbaud	125, 250 and 500 Kbaud

Options Variant independent options

Technical data (continued)

		CANopen module 6SE6400-1CB00-0AA0	Pulse encoder evaluation module 6SE6400-0EN00-0AA0
			
Size (height x width x depth)		161 mm x 73 mm x 46 mm	161 mm x 73 mm x 42 mm
Degree of protection		IP20	
Degree of pollution		2 to IEC 60 664-1 (DIN VDE 0110/T1), no condensation permitted during operation	
Strain resistance		to IEC 60 068-2-6 (if module is installed correctly)	
• Stationary	Deflection	0.15 mm in the frequency range of 10 Hz to 58 Hz	
	Acceleration	19.6 m/s ² in the frequency range of >58 Hz to 500 Hz	
• Transport	Deflection	3.5 mm in the frequency range of 5 Hz to 9 Hz	
	Acceleration	9.8 m/s ² in the frequency range of 9 Hz to 500 Hz	
Climatic category (during operation)		3K3 to IEC 60 721-3-3	
Cooling method		Natural air cooling	
Permissible ambient or cooling agent temperature			
• Operation		-10 °C to +50 °C (+14 °F to +122 °F)	-10 °C to +50 °C (+14 °F to +122 °F)
• Storage		-40 °C to +70 °C (-40 °F to +158 °F)	-20 °C to +70 °C (-14 °F to +158 °F)
• Transportation		-25 °C to +70 °C (-13 °F to +158 °F)	-20 °C to +70 °C (-14 °F to +158 °F)
Electromagnetic compatibility		to EN 55 011 (1991) Class A	
	Emission	to IEC 60 801-3 and EN 61 000-4-3	
	Interference		
Relative humidity (permissible humidity rating)			
• Operation		≤ 85 % (non-condensing)	
• Storage and transport		≤ 95 %	
Power supply		The CAN bus is supplied from the inverter power supply	5 V ± 5 %, 330 mA or 18 V non-regulated, 140 mA, short-circuit proof
Data transmission rate		10, 20, 50, 125, 250, 500, 800 kbaud and 1 Mbaud	-
Pulse frequency		-	max. 300 kHz

Selection and ordering data

Type of documentation	Language	Order No.
Docu pack , supplied with each inverter, containing CD-ROM ¹⁾ and Getting Started Guide ²⁾ (paper version)	Multilanguage	6SE6400-5AD00-1AP1
Operating instructions²⁾ (paper version)	German	6SE6400-5AW00-0AP0
	English	6SE6400-5AW00-0BP0
	French	6SE6400-5AW00-0DP0
	Italian	6SE6400-5AW00-0CP0
	Spanish	6SE6400-5AW00-0EP0
Parameter list ²⁾ (paper version)	German	6SE6400-5BB00-0AP0
	English	6SE6400-5BB00-0BP0
	French	6SE6400-5BB00-0DP0
	Italian	6SE6400-5BB00-0CP0
	Spanish	6SE6400-5BB00-0EP0

1) The CD-ROM contains operating instructions, parameter list, commissioning tools STARTER and DriveMonitor, multilanguage.

Available on the Internet:
DriveMonitor at
<http://www4.ad.siemens.de/WW/view/com/10804984/133100>

STARTER at
<http://www4.ad.siemens.de/WW/view/com/10804985/133100>

2) Available on the Internet at
<http://www.siemens.com/micromaster>

MICROMASTER 440

Dimension drawings

MICROMASTER 440 inverter

Frame size	1/3 AC 200 V to 240 V	3 AC 380 V to 480 V	3 AC 500 V to 600 V
A	0.12 kW to 0.75 kW	0.37 kW to 1.5 kW	–
B	1.1 kW to 2.2 kW	2.2 kW to 4 kW	–
C	3 kW to 5.5 kW	5.5 kW to 11 kW	0.75 kW to 11 kW

The specified outputs are valid for CT mode.

Note:
The inverters must not be mounted horizontally. But the inverters can be mounted without lateral spacing.

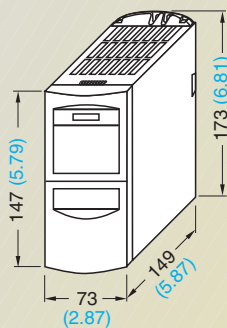

Inverter frame size **A**

Drill and fixing pattern

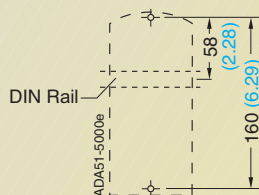

Fixing with 2 x M4 bolts, 2 x M4 nuts,
2 x M4 washers
or by snapping onto a rail
Tightening torque with washers fitted:
2.5 Nm
Ventilation clearance required
Top and bottom: 100 mm

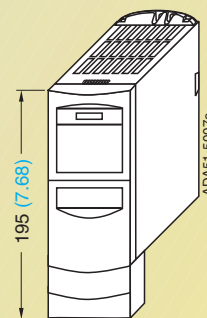

Inverter frame size **A** with **gland plate**

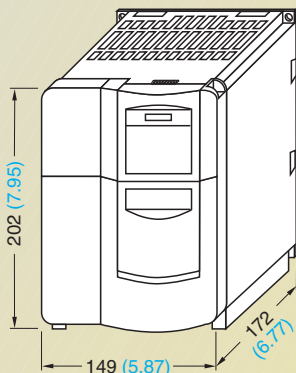

Inverter frame size **B**

Drill pattern

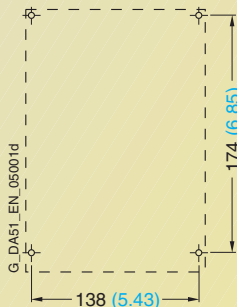

Fixing with 4 x M4 bolts, 4 x M4 nuts,
4 x M4 washers
Tightening torque with washers fitted:
2.5 Nm
Ventilation clearance required
Top and bottom: 100 mm

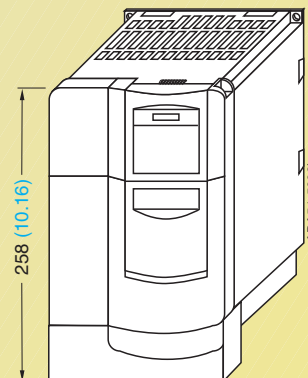

Inverter frame size **B** with **gland plate**

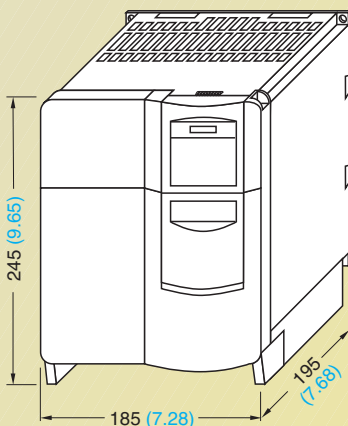

Inverter frame size **C**

Drill pattern

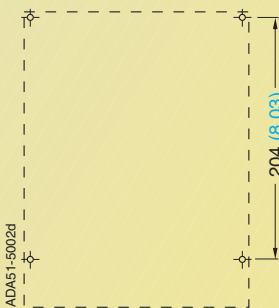

Fixing with 4 x M5 bolts, 4 x M5 nuts,
4 x M5 washers
Tightening torque with washers fitted:
3.0 Nm
Ventilation clearance required
Top and bottom: 100 mm

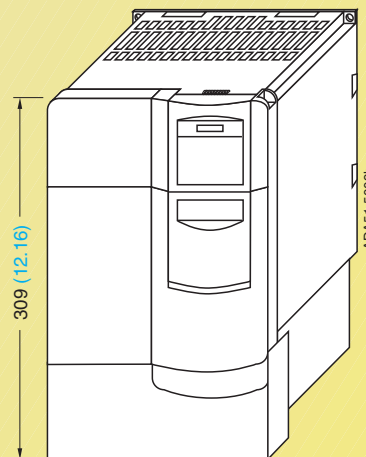

Inverter frame size **C** with **gland plate**

With the communications module, the mounting depth increases by 23 mm (0.91 inches). If a pulse encoder evaluation module is mounted in addition, the installation depth increases by another 23 mm (0.91 inches).

All dimensions in mm (values in brackets are in inches)

MICROMASTER 440 inverter (continued)

Frame size	3 AC 200 V to 240 V	3 AC 380 V to 480 V	3 AC 500 V to 600 V
D	7.5 kW to 15 kW	15 kW to 22 kW	15 kW to 22 kW
E	18.5 kW to 22 kW	30 kW to 37 kW	30 kW to 37 kW
F	30 kW to 45 kW	45 kW to 75 kW	45 kW to 75 kW

The specified outputs are valid for CT mode.

Note:
The inverters must not be mounted horizontally. But the inverters can be mounted without lateral spacing.

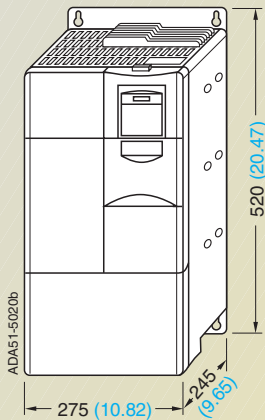

Inverter frame size D



Fixing with
4 x M8 bolts, 4 x M8 nuts,
4 x M8 washers

Tightening torque with washers
fitted: 3.0 Nm
Ventilation clearance required
Top and bottom: 300 mm

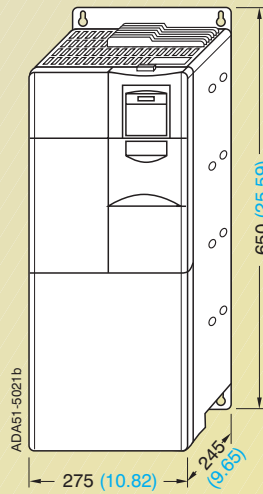

Inverter frame size E



Fixing with
4 x M8 bolts, 4 x M8 nuts,
4 x M8 washers

Tightening torque with washers fitted:
3.0 Nm
Ventilation clearance required
Top and bottom: 300 mm

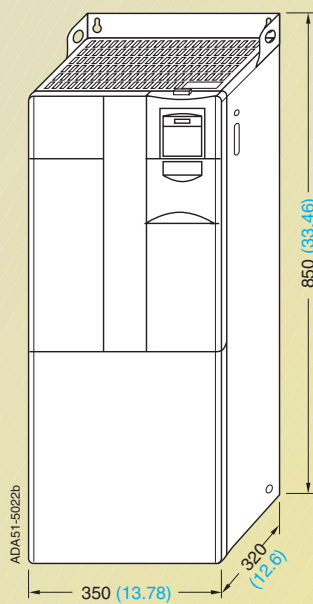

**Inverter frame size F
without filter**



Fixing with
4 x M8 bolts, 4 x M8 nuts,
4 x M8 washers

Tightening torque with washers
fitted: 3.0 Nm
Ventilation clearance required
Top and bottom: 350 mm

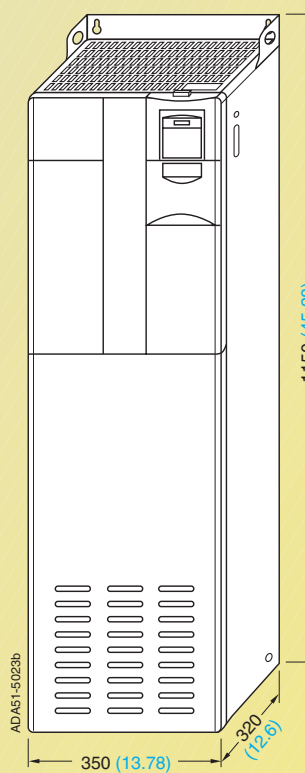

**Inverter frame size F
with filter**

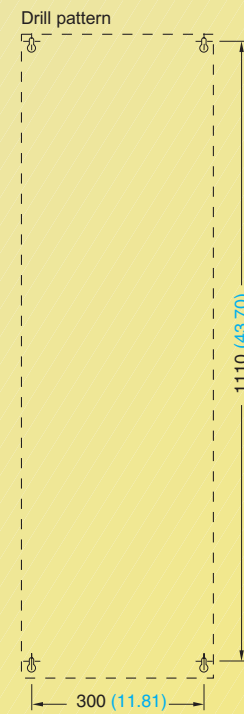

Fixing with
4 x M8 bolts, 4 x M8 nuts,
4 x M8 washers

Tightening torque with washers
fitted: 3.0 Nm
Ventilation clearance required
Top and bottom: 350 mm

All dimensions in mm (values in brackets are in inches)

MICROMASTER 440

Dimension drawings

MICROMASTER 440 inverter (continued)

Frame size	3 AC 380 V to 480 V
FX	90 kW to 110 kW
GX	132 kW to 200 kW

The specified outputs are valid for CT mode.

Note:
The inverters must not be mounted horizontally. But the inverters can be mounted without lateral spacing.

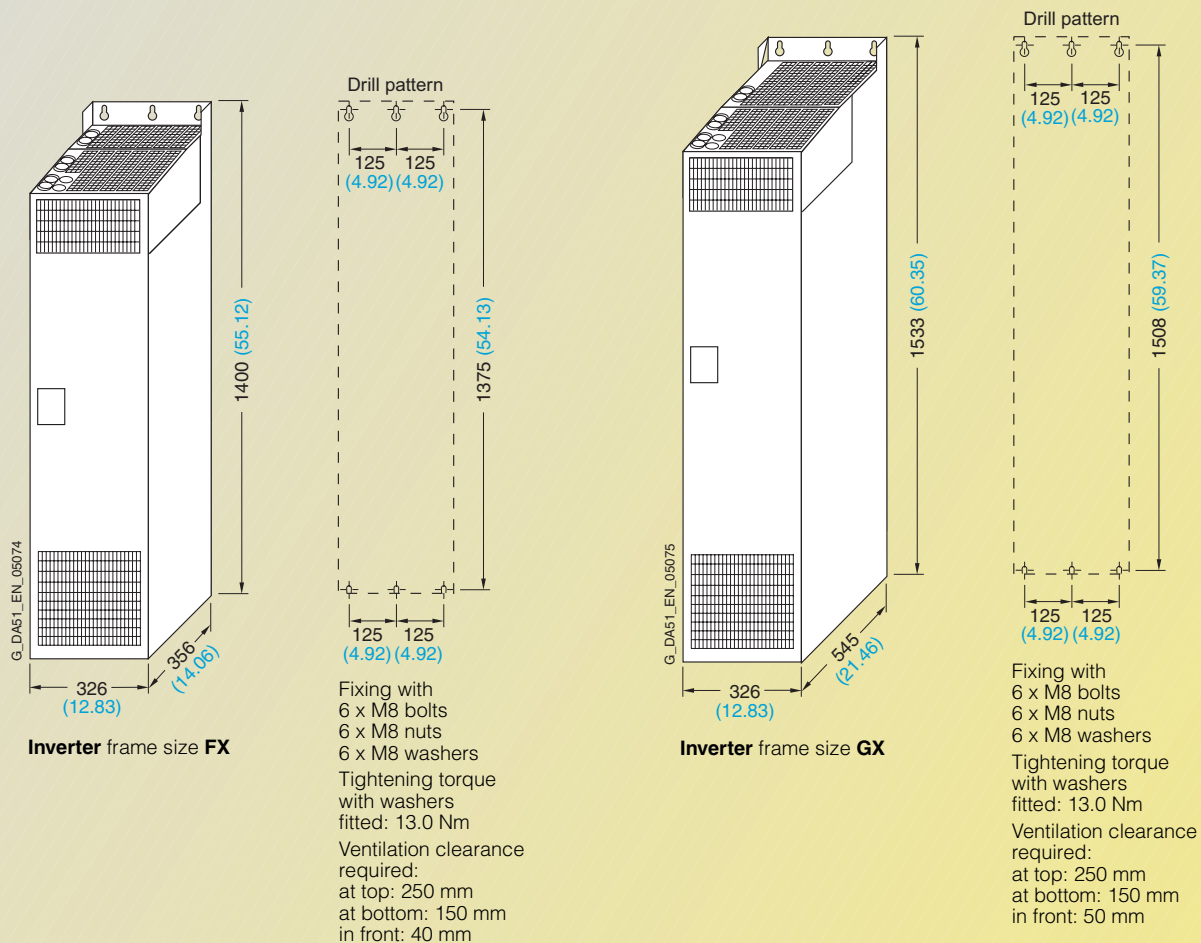

All dimensions in mm (values in brackets are in inches)

EMC filter

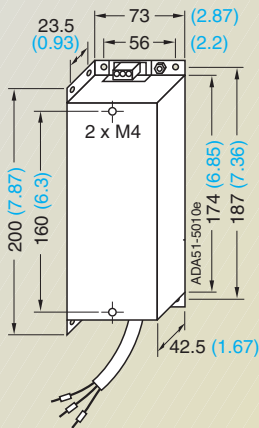

EMC filter for frame size **A**

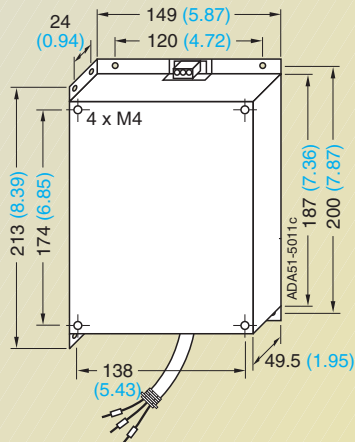

For frame size **B**

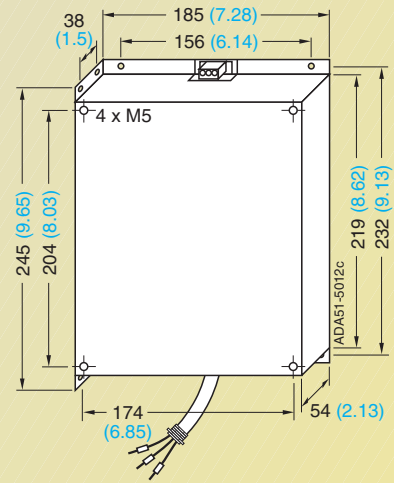

For frame size **C**

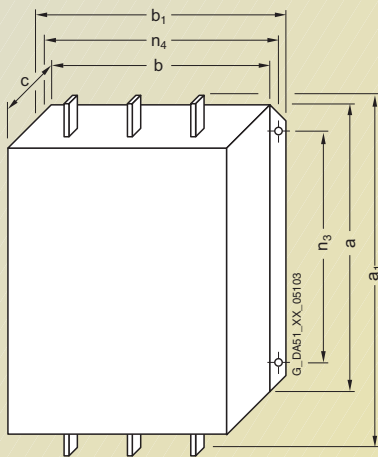

EMC filter Class A Type 6SL3000-	for inverter Frame size (FS)	Dimensions							Weight, approx kg
		a	a ₁	b	b ₁	c	n ₃	n ₄	
OBE32-5AAO	FX	270 (10.63)	360 (14.17)	200 (7.87)	240 (9.45)	116 (4.57)	210 (8.27)	220 (8.66)	12.3
OBE34-4AAO	GX/GX	270 (10.63)	360 (14.17)	200 (7.87)	240 (9.45)	116 (4.57)	210 (8.27)	220 (8.66)	12.3
OBE36-0AAO	GX	310 (12.2)	400 (15.75)	215 (8.46)	265 (10.43)	140 (5.51)	250 (9.84)	240 (9.45)	19.0

EMC filter for frame sizes **FX** and **GX**

All dimensions in mm (values in brackets are in inches)

Dimension drawings

LC filter

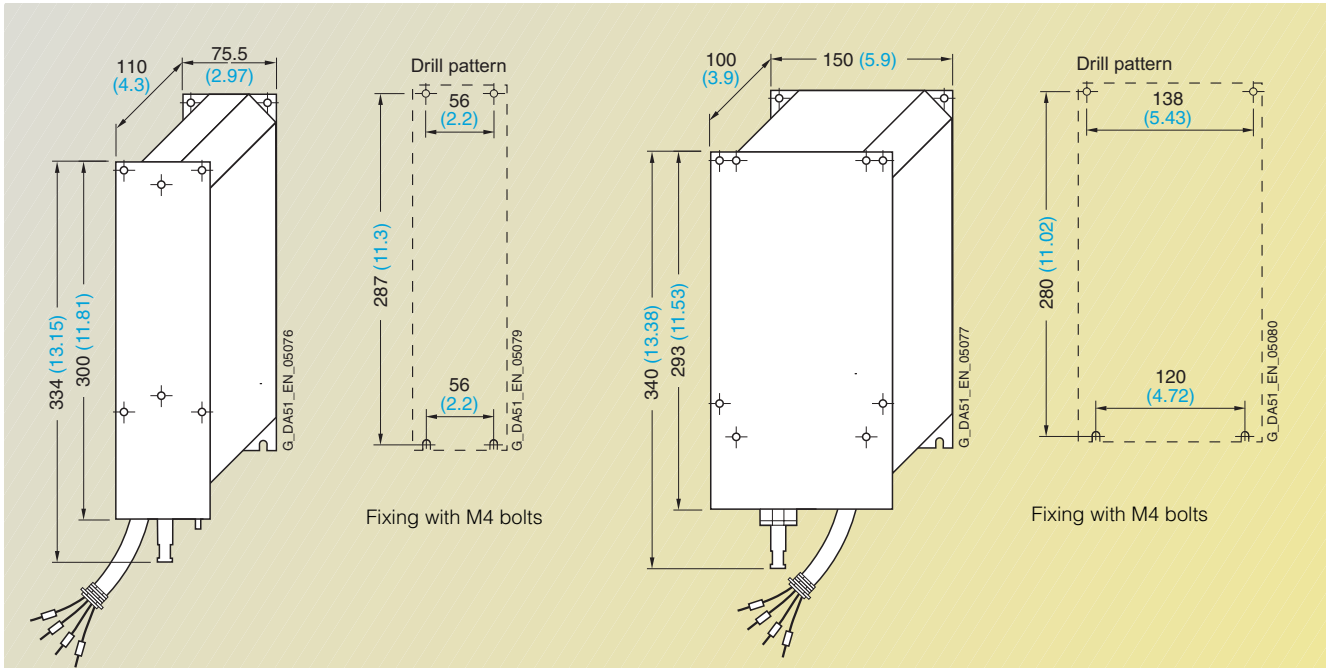

LC filter for frame size **A**

For frame size **B**

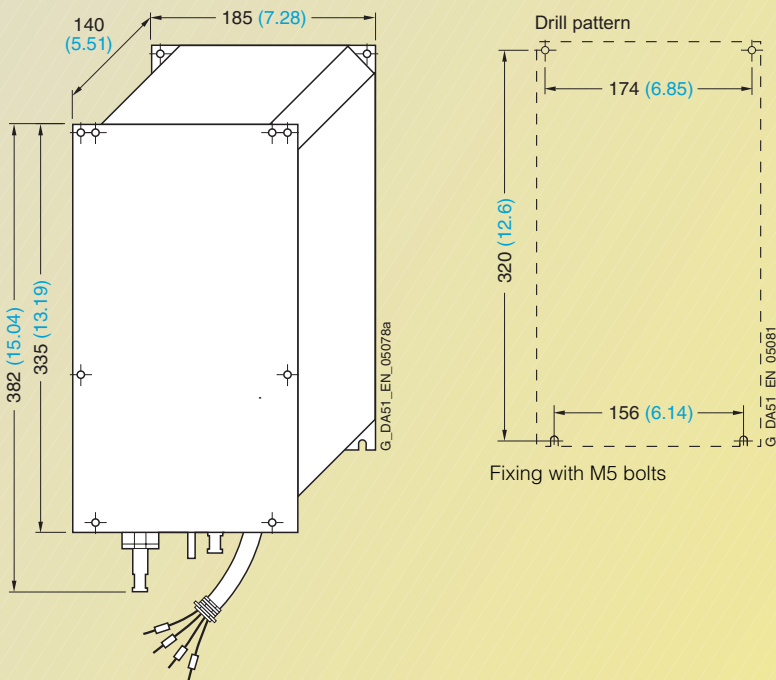

LC filter for frame size **C**

All dimensions in mm (values in brackets are in inches)

LC filter

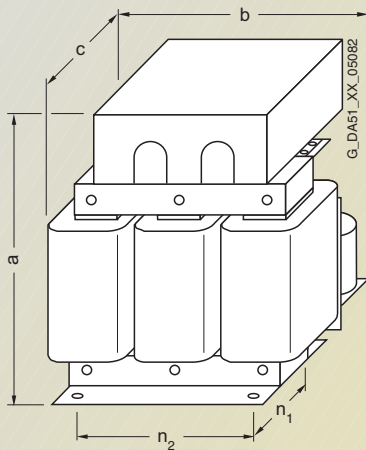

Fixing with M10 bolts

LC filter for frame sizes **D** to **F**

LC filter Type	for inverter Frame size (FS)	Dimensions				
		a	b	c	n ₁	n ₂
6SE6400-3TD03-7DD0	D	278 (10.94)	240 (9.45)	230 (9.06)	115 (4.53)	190 (7.48)
6SE6400-3TD04-8DD0	D	290 (11.42)	240 (9.45)	240 (9.45)	125 (4.92)	190 (7.48)
6SE6400-3TD06-1DD0	D	345 (13.58)	300 (11.81)	220 (8.66)	120 (4.72)	240 (9.45)
6SE6400-3TD02-3DE0	D	280 (11.02)	240 (9.45)	240 (9.45)	125 (4.92)	190 (7.48)
6SE6400-3TD03-2DE0	D	300 (11.81)	300 (11.81)	235 (9.25)	133 (5.24)	240 (9.45)
6SE6400-3TD03-7DE0	D	310 (12.2)	300 (11.81)	250 (9.84)	145 (5.71)	240 (9.45)
6SE6400-3TD07-2ED0	E	355 (13.98)	300 (11.81)	235 (9.25)	145 (5.71)	240 (9.45)
6SE6400-3TD04-8EE0	E	345 (13.58)	300 (11.81)	260 (10.24)	160 (6.3)	240 (9.45)
6SE6400-3TD06-1EE0	E	345 (13.58)	300 (11.81)	275 (10.83)	171 (6.73)	240 (9.45)
6SE6400-3TD11-5FD0	E/F	460 (18.11)	360 (14.17)	235 (9.25)	125 (4.92)	264 (10.39)
6SE6400-3TD15-0FD0	F	460 (18.11)	360 (14.17)	250 (9.84)	140 (5.51)	264 (10.39)
6SE6400-3TD18-0FD0	F	520 (20.47)	420 (16.54)	290 (11.42)	173 (6.81)	316 (12.44)
6SE6400-3TD07-1FE0	F	380 (14.96)	300 (11.81)	285 (11.22)	171 (6.73)	240 (9.45)
6SE6400-3TD10-0FE0	F	460 (18.11)	360 (14.17)	250 (9.84)	140 (5.11)	264 (10.39)
6SE6400-3TD11-5FE0	F	515 (20.28)	420 (16.54)	290 (11.42)	173 (6.81)	316 (12.44)

All dimensions in mm (values in brackets are in inches)

Dimension drawings

Sinusoidal filter

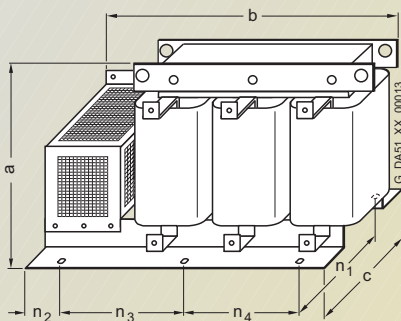

Sinusoidal filter for frame sizes **FX** and **GX**

Sinusoidal filter Type 6SL3000-	for inverter Frame size (FS)	Dimensions							Weight (max.) kg
		a	b	c	n ₁	n ₂	n ₃	n ₄	
2CE32-3AA0	FX	300 (11.81)	620 (24.41)	320 (12.6)	280 (11.02)	105 (4.13)	225 (8.86)	150 (5.91)	135.0
2CE32-8AA0	GX	300 (11.81)	620 (24.41)	320 (12.6)	280 (11.02)	105 (4.13)	225 (8.86)	150 (5.91)	138.0

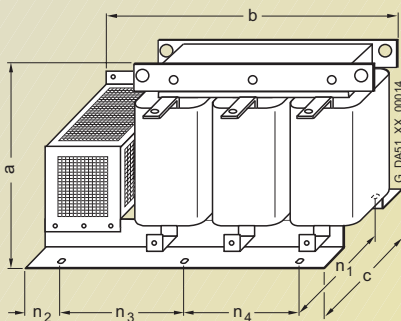

Sinusoidal filter for frame size **GX**

Sinusoidal filter Type 6SL3000-	for inverter Frame size (FS)	Dimensions							Weight (max.) kg
		a	b	c	n ₁	n ₂	n ₃	n ₄	
2CE33-3AA0	GX	370 (14.57)	620 (24.41)	360 (14.17)	320 (12.6)	105 (4.13)	225 (8.86)	150 (5.91)	144.0
2CE34-1AA0	GX	370 (14.57)	620 (24.41)	360 (14.17)	320 (12.6)	105 (4.13)	225 (8.86)	150 (5.91)	208.0

All dimensions in mm (values in brackets are in inches)

Line commutating chokes

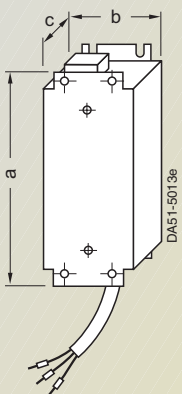

Line commutating choke for frame size **A**

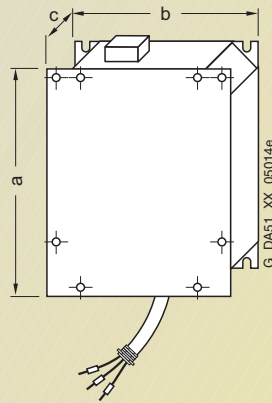

For frame sizes **B** and **C**

Line commutating choke for	Dimensions			Weight (max.) kg
	a	b	c	
Frame size A	200 (7.87)	75.5 (2.97)	50 (1.97)	0.8
Frame size B	213 (8.39)	150 (5.91)	50 (1.97)	1.3
Frame size C (380–480 V)	280 (11.02)	185 (7.28)	50 (1.97)	2.3
Frame size C (500–600 V, 0.75–1.5 kW)	280 (11.02)	185 (7.28)	50 (1.97)	4.4
Frame size C (500–600 V, 2.2–4 kW)	280 (11.02)	185 (7.28)	50 (1.97)	5.0
Frame size C (500–600 V, 5.5–11 kW)	280 (11.02)	185 (7.28)	80 (3.15)	6.8

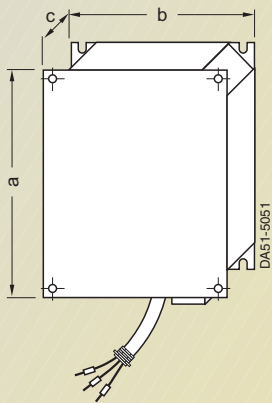

Line commutating choke for frame sizes **D** and **E**

Line commutating choke for	Dimensions			Weight (max.) kg
	a	b	c	
Frame size D	520 (20.47)	275 (10.83)	85 (3.35)	9.5
Frame size E	650 (25.59)	275 (10.83)	95 (3.74)	17.0

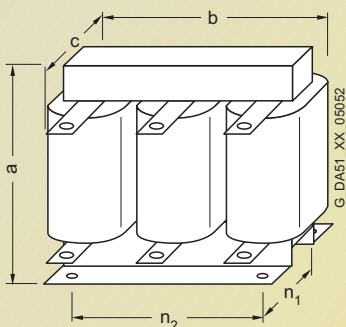

Line commutating choke for inverter frame size **F**

Line commutating choke Type	for inverter Frame size (FS)	Dimensions					Weight (max.) kg
		a	b	c	n ₁	n ₂	
6SE6400-3CC11-....	F	228 (8.98)	240 (9.45)	141 (5.55)	95 (3.74)	185 (7.28)	25.0

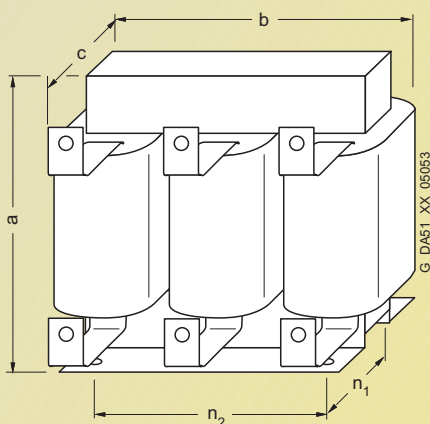

Line commutating choke for inverters of frame sizes **FX** and **GX**

Line commutating choke Type	for inverter Frame size (FS)	Dimensions					Weight (max.) kg
		a	b	c	n ₁	n ₂	
0CE32-....	FX	248 (9.76)	255 (10.04)	203 (7.99)	101 (3.98)	200 (7.87)	24.0
0CE33-....	GX	248 (9.76)	255 (10.04)	203 (7.99)	101 (3.98)	200 (7.87)	25.0
0CE35-....	GX	269 (10.59)	275 (10.83)	210 (8.27)	118 (4.65)	224 (8.82)	35.0

All dimensions in mm (values in brackets are in inches)

Dimension drawings

Output chokes

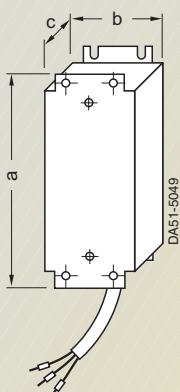

Output choke
for frame size **A**
6SE6400-3TC00-4AD2
6SE6400-3TC00-4AD3

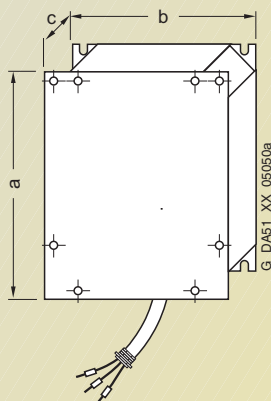

For frame sizes **B** and **C**
6SE6400-3TC01-0BD3
6SE6400-3TC01-8CE3
6SE6400-3TC03-2CD3

Output choke Type 6SE6400-	Dimensions			Weight (max.) kg
	a	b	c	
3TC00-4AD2	200 (7.87)	75.5 (2.97)	110 (4.33)	1.95
3TC00-4AD3	200 (7.87)	75.5 (2.97)	50 (1.97)	0.8
3TC01-0BD3	213 (8.39)	150 (5.91)	70 (2.76)	3.4
3TC01-8CE3	245 (9.65)	185 (7.28)	150 (5.91)	9.6
3TC03-2CD3	245 (9.65)	185 (7.28)	80 (3.15)	5.6

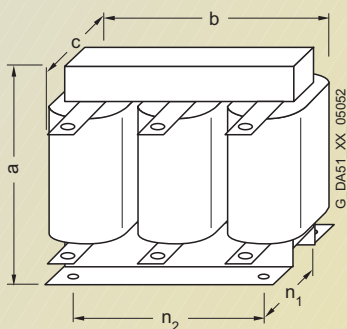

Output chokes
for inverters of frame sizes **D**, **E** and **F**

Output choke Type 6SE6400-	for inverter Frame size (FS)	Dimensions			to DIN 41 308		Weight (max.) kg
		a	b	c	n ₁	n ₂	
3TC03-2DE0	D	210 (8.27)	225 (8.86)	179 (7.05)	94 (3.70)	176 (6.93)	16.0
3TC03-8DD0	D	210 (8.27)	225 (8.86)	179 (7.05)	94 (3.70)	176 (6.93)	16.1
3TC05-4DD0	D	210 (8.27)	225 (8.86)	150 (5.91)	70 (2.76)	176 (6.93)	10.7
3TC06-2FE0	F	269 (10.59)	300 (11.81)	220 (8.66)	118 (4.65)	224 (8.82)	33.9
3TC07-5ED0	E	248 (9.76)	270 (10.63)	209 (8.23)	101 (3.98)	200 (7.87)	24.9
3TC08-0ED0	E	210 (8.27)	225 (8.86)	150 (5.91)	70 (2.76)	176 (6.93)	10.4
3TC08-8FE0	F	321 (12.64)	350 (13.78)	288 (11.34)	138 (5.43)	264 (10.39)	51.5
3TC14-5FD0	F	321 (12.64)	350 (13.78)	288 (11.34)	138 (5.43)	264 (10.39)	51.5
3TC15-4FD0	F	248 (9.76)	270 (10.63)	209 (8.23)	101 (3.98)	200 (7.87)	24.0

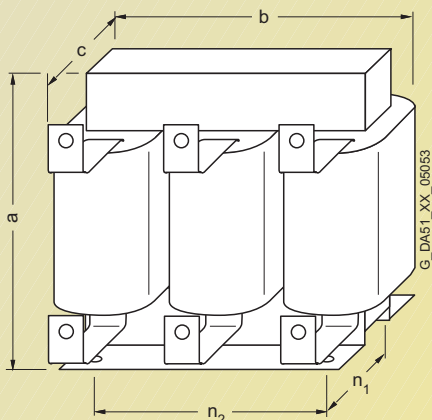

Output chokes
for inverters of frame sizes **FX** and **GX**

Output choke Type 6SL3000-	for inverter Frame size (FS)	Dimensions					Weight (max.) kg
		a	b	c	n ₁	n ₂	
2BE32-1AA0	FX	285 (11.22)	300 (11.81)	257 (10.12)	163 (6.42)	224 (8.82)	60.0
2BE32-6AA0	FX	315 (12.4)	300 (11.81)	277 (10.91)	183 (7.2)	224 (8.82)	66.0
2BE33-2AA0	GX	285 (11.22)	300 (11.81)	257 (10.12)	163 (6.42)	224 (8.82)	62.0
2BE33-8AA0	GX	285 (11.22)	300 (11.81)	277 (10.91)	183 (7.2)	224 (8.82)	73.0
2BE35-0AA0	GX	365 (14.37)	300 (11.81)	277 (10.91)	183 (7.2)	224 (8.82)	100.0

All dimensions in mm (values in brackets are in inches)

Brake resistors

Fig. 1:

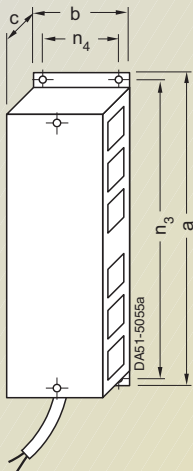

Fig. 2:

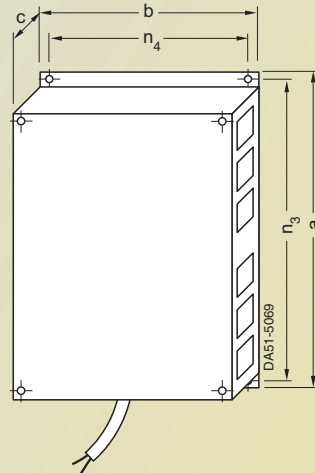
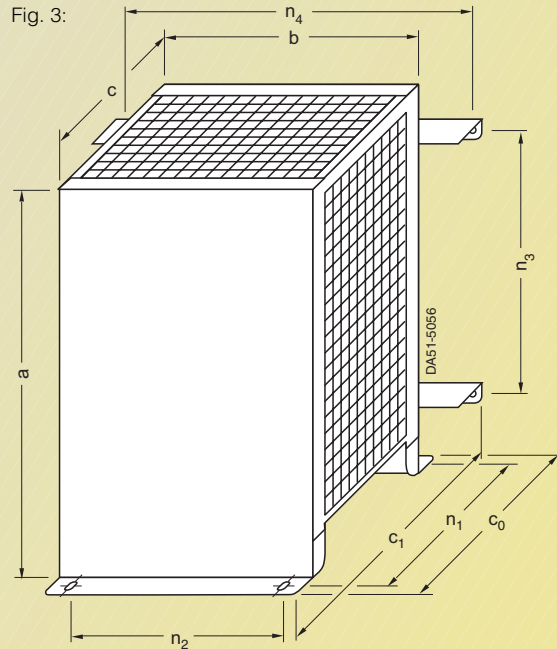

Fig. 3:



Brake resistors Type 6SE6400-	Resistor Ohm	for inverter Frame size (FS)	Figure No.	Dimensions					For floor mounting		For wall mounting		Weight (max.) kg
				a	b	c	c ₀	c ₁	n ₁	n ₂	n ₃	n ₄	
4BC05-0AA0	180	A	1	230 (9.06)	72 (2.83)	43.5 (1.71)	-	-	-	-	217 (8.54)	56 (2.20)	1.0
4BC11-2BA0	68	B	2	239 (9.41)	149 (5.87)	43.5 (1.71)	-	-	-	-	226 (8.90)	138 (5.43)	1.6
4BC12-5CA0	39	C	3	285 (11.22)	185 (7.28)	150 (5.91)	185 (7.28)	217 (8.54)	170 (6.69)	145 (5.71)	200 (7.87)	230 (9.06)	3.8
4BC13-0CA0	27	C	3	285 (11.22)	185 (7.28)	150 (5.91)	185 (7.28)	217 (8.54)	170 (6.69)	145 (5.71)	200 (7.87)	230 (9.06)	3.8
4BC18-0DA0	10	D	3	515 (20.28)	270 (10.63)	175 (6.89)	210 (8.27)	242 (9.53)	195 (7.68)	205 (8.07)	350 (13.78)	315 (12.40)	7.4
4BC21-2EA0	6.8	E	3	645 (25.39)	270 (10.63)	175 (6.89)	210 (8.27)	242 (9.53)	195 (7.68)	205 (8.07)	480 (18.90)	315 (12.40)	10.6
4BC22-5FA0	3.3	F	3	650 (25.59)	400 (15.75)	315 (12.40)	382 (15.04)	382 (15.04)	335 (13.19)	270 (10.63)	510 (20.08)	435 (17.13)	16.7
4BD11-0AA0	390	A	1	230 (9.06)	72 (2.83)	43.5 (1.71)	-	-	-	-	217 (8.54)	56 (2.20)	1.0
4BD12-0BA0	160	B	2	239 (9.41)	149 (5.87)	43.5 (1.71)	-	-	-	-	226 (8.90)	138 (5.43)	1.6
4BD16-5CA0	56	C	3	285 (11.22)	185 (7.28)	150 (5.91)	185 (7.28)	217 (8.54)	170 (6.69)	145 (5.71)	200 (7.87)	230 (9.06)	3.8
4BD21-2DA0	27	D	3	515 (20.28)	270 (10.63)	175 (6.89)	210 (8.27)	242 (9.53)	195 (7.68)	205 (8.07)	350 (13.78)	315 (12.40)	7.4
4BD22-2EA0	15	E	3	645 (25.39)	270 (10.63)	175 (6.89)	210 (8.27)	242 (9.53)	195 (7.68)	205 (8.07)	480 (18.90)	315 (12.40)	10.6
4BD24-0FA0	8.2	F	3	650 (25.59)	400 (15.75)	315 (12.40)	382 (15.04)	382 (15.04)	335 (13.19)	270 (10.63)	510 (20.08)	435 (17.13)	16.7
4BE14-5CA0	120	C	3	285 (11.22)	185 (7.28)	150 (5.91)	185 (7.28)	217 (8.54)	170 (6.69)	145 (5.71)	200 (7.87)	230 (9.06)	3.8
4BE16-5CA0	82	C	3	285 (11.22)	185 (7.28)	150 (5.91)	185 (7.28)	217 (8.54)	170 (6.69)	145 (5.71)	200 (7.87)	230 (9.06)	3.8
4BE21-3DA0	39	D	3	515 (20.28)	270 (10.63)	175 (6.89)	210 (8.27)	242 (9.53)	195 (7.68)	205 (8.07)	350 (13.78)	315 (12.40)	7.4
4BE21-8EA0	27	E	3	645 (25.39)	270 (10.63)	175 (6.89)	210 (8.27)	242 (9.53)	195 (7.68)	205 (8.07)	480 (18.90)	315 (12.40)	10.6
4BE24-2FA0	12	F	3	650 (25.59)	400 (15.75)	315 (12.40)	382 (15.04)	382 (15.04)	335 (13.19)	270 (10.63)	510 (20.08)	435 (17.13)	16.7

Brake resistors for inverters of frame sizes **A** to **F**

All dimensions in mm (values in brackets are in inches)

MICROMASTER 440

Notes

4





MICROMASTER 410/420/430/440

Appendix



A/2	Environment, resources and recycling
A/2	Certificates
A/4	Compliance with standards
A/6	Integration of drives into the SIMATIC S7 automation system with Drive ES
A/7	Software update service for Drive ES
A/7	Drive technology for the chemicals industry
A/8	Demonstration case
A/8	Standard conversion factors: metric to US units
A/9	Training
A/10	Overview of SIMATIC ET 200S FC
A/11	Overview of SINAMICS G110
A/12	Overview of motors
A/13	Overview of MICROMASTER 411/ COMBIMASTER 411/Geared motors
A/14	Siemens contacts worldwide
A/15	Online services
A/16	Service & Support
A/18	Subject index
A/19	Order No. index Notes on ordering
A/20	Conditions of sale and delivery Export regulations

Appendix

Environment, resources and recycling

Siemens AG feels a responsibility to play a role in protecting our environment and saving our valuable natural resources. This is true for both our production and our products.

Even during development, we consider any possible environmental impact of future products/systems. Our aim is to prevent harmful environmental effects or at least to reduce them to an absolute minimum – beyond present regulations and legislation.

The most important activities for protecting our environment are as follows:

- We are constantly endeavoring to reduce the environmental impact of our products as well as their consumption of energy and resources over and above the statutory environmental protection regulations.
- We take every possible step to prevent damage to the environment.
- Environmental impact is assessed and considered at the earliest possible stage of product and process planning.

- Our optimized environmental management strategy ensures that our environmental policy is put into practice effectively. The necessary technical and organizational procedures are reviewed at regular intervals and continuously updated.
- An awareness for environmental problems is expected of all our employees. Establishing and furthering a sense of responsibility for the environment on all levels represents a permanent challenge for the corporate management.
- We urge our business partners to act according to the same environmental principles as ourselves. We cooperate with the responsible public authorities.
- We inform interested members of the public about the consequences of our corporate policies for the environment as well as our achievements to the benefit of the environment.
- Our complete documentation is printed on chlorine-free bleached paper.

Certificates



Certificates (continued)

SIEMENS

EG-Konformitätserklärung
Nr.: 654.20001.21

Hersteller: **Siemens AG**
Automation and Drives
Standard Drives

Anschrift: **Frauenauracherstr. 80**
91056 Erlangen
Deutschland

Produktbezeichnung: **MICROMASTER 410 / 6SE6410.....X*
MICROMASTER 420 / 6SE6420.....X*
MICROMASTER 430 / 6SE6430.....X*
MICROMASTER 440 / 6SE6440.....X*
* Baugrößen A bis G**

Das bezeichnete Produkt stimmt mit den Vorschriften folgender Europäischer Richtlinien überein:

73/23/EWG Richtlinie des Rates zur Angleichung der Rechtsvorschriften der Mitgliedstaaten betreffend elektrischer Betriebsmittel zur Verwendung innerhalb bestimmter Spannungsgrenzen, geändert durch RL 93/55/EWG des Rates

Die Übereinstimmung mit den Vorschriften dieser Richtlinien wird nachgewiesen durch die vollständige Einhaltung folgender Normen:

EN 50178 EN 60204-1

Das bezeichnete Produkt ist zum Einbau in eine andere Maschine bestimmt. Die Inbetriebnahme ist solange untersagt, bis die Konformität des Endproduktes mit der Richtlinie 98/37/EG festgestellt ist.

Erlaubtgebe: 03.10.2000
Erlangen, den 
R.-M. Fomke
Labor Research and Development Drives

H.-J. Friesen
Labor Quality Management

Diese Erklärung ist keine Zusage von Eigenesher für im Sinne der Produkthaftung.
Die Sicherheitsanweise der Produktdokumentation sind zu beachten.

Legend for EC declaration of conformity:

The named product is in conformity with the requirements of the following European Directive:
73/23/EEC Council Directive on the approximation of the laws of the Member States relating to electrical equipment for use within certain voltage limits, amended by Council Directive RL 93/68/EEC

Conformity with the requirements of these Directives is testified by complete adherence to the following standards:

The named product is intended for fitting in another machine. Commissioning is prohibited until such time as the end product has been proved to conform to the provisions of Directive 98/37/EC. This declaration does not give assurance of properties within the meaning of product liability. The safety instructions provided in the product documentation must be observed.



Compliance with standards

CE marking



The MICROMASTER inverters meet the requirements of the Low-Voltage Directive 73/23/EEC.

Low-voltage directive

The inverters comply with the following standards listed in the Official Journal of the European Communities:

• EN 60 204

Safety of machinery, electrical equipment of machines

• EN 50 178

Electrical equipment in electrical power installations.

Machine directive

The inverters are suitable for installation in machines. Compliance with the machine directive 89/392/EEC requires a separate certificate of conformity. This must be furnished by the plant constructor or the installer of the machine.

EMC directive

• EN 61 800-3

Variable-speed electric drives Part 3: EMC product standard including special test procedure.

The new EMC product standard EN 61 800-3 applies to electrical drive systems as of July 1, 2005. The transition period for the preceding standard EN 61 800-3/A11 dated February 2001 ends on October 1, 2007. The following explanations apply to frequency inverters of the 6SE6 series from Siemens:

- The EMC product standard EN 61 800-3 does not apply directly to a frequency inverter but to a PDS (Power Drive System), which comprises the complete circuitry, motor and cables in addition to the inverter.

- As a rule, frequency inverters are only supplied to qualified technical specialists for installation in machines or plants. A frequency inverter must therefore only be considered as a component which, as such, is not subject to the EMC product standard EN 61 800-3. However, the inverter's instruction manual specifies the conditions under which the product standard can be complied with if the frequency inverter is expanded to become a PDS. For a PDS, the EMC directive in the EU is complied with through observance of the product standard EN 61 800-3 for variable-speed electrical drive systems. The frequency inverters on their own do not generally require marking according to the EMC directive.

- The new EN 61 800-3 of July 2005 no longer distinguishes between "general availability" and "restricted availability". Instead, different categories, namely C1 to C4, are defined according to the environment of the PDS at the place of use:

– Category C1:

Drive systems for rated voltages of < 1000 V for use in the first environment

– Category C2:

Fixed-location drive systems which are not connected by means of plug-in devices, for rated voltages of < 1000 V. If used in the first environment, installation and start-up may only be carried out by qualified EMC personnel. Warning information must be provided.

– Category C3:

Drive systems for rated voltages of < 1000 V, solely for use in the second environment. Warning information must be provided.

– Category C4:

Drive systems for rated voltages of ≥ 1000 V or for rated currents of ≥ 400 A or for use in complex systems in the second environment. An EMC plan must be drawn up.

- In the EMC product standard EN 61 800-3, limits for conducted interference voltages and radiated interference are also indicated for the so-called "second environment" (= industrial power supply systems which do not supply households). These limits are lower than the limits of filter class A according to EN 55 011. The use of unfiltered inverters in an industrial environment is permissible provided they are part of a system that is equipped with line filters on the higher-level infeed side.
- With MICROMASTER, power drive systems (PDS) which comply with EMC product standard EN 61 800-3 can be installed (see the installation instructions in the product documentation). The table entitled "Overview of MICROMASTER components and PDS categories" and the MICROMASTER ordering documents show which components the respective PDS installation supports directly.
- In general, a distinction must be made between the product standards for electrical drive systems (PDS) of the EN 61 800 series of standards (of which Part 3 covers EMC topics) and the product standards for devices/systems/machines etc. This will probably not result in any changes in the practical use of frequency inverters. Since frequency inverters are always part of a PDS and the latter is part of a machine, the manufacturer of the machine must observe various standards depending on the type of machine and the environment, e.g. EN 61 000-3-2 for power supply harmonics and EN 55 011 for radio interference. The PDS product standard alone is therefore inadequate or irrelevant.
- With regard to compliance with limits for power supply harmonics, the EMC product standard EN 61 800-3 for PDS refers to compliance with the EN 61 000-3-2 and EN 61 000-3-12 standards.
- Irrespective of configuration with MICROMASTER and its components, the machine builder can also modify the machines in other ways in order to comply with the EMC directive of the EU. As a rule, the EMC directive of the EU is observed through compliance with the EMC product standards applicable to the machine. If they are not available, the generic standards such as DIN EN 61 000-x-x can be used instead. What is important is that the conducted interference and the radiated interference voltages at the power-supply connection point and outside the machine remain below the corresponding limits. What technical means are used to ensure this is not prescribed.

Overview of MICROMASTER components and PDS categories

First environment (residential, commercial)	Category C1 Unfiltered devices plus external Class B filter with low leakage currents	Second environment (industrial)
	Category C2 Devices with an integrated Class B filter or devices with an integrated Class A filter plus external supplementary filter Class B or devices with an integrated Class A filter plus warning information or unfiltered devices plus external Class A filter plus warning information	Devices with an integrated Class B filter or devices with an integrated Class A filter plus external supplementary filter Class B or devices with an integrated Class A filter or unfiltered devices plus external Class A filter Note: The requirements of EN 61 800-3 are considerably exceeded if Class B filters are used.
	Category C3 Devices with integrated Class A filter or unfiltered devices plus external Class A filter Warning information is necessary. Note: The requirements of EN 61 800-3 are considerably exceeded if Class A filters are used.	
	Category C4 Unfiltered devices plus external Class A filter An EMC plan must be drawn up. Note: The requirements of EN 61 800-3 are considerably exceeded if Class A filters are used.	

Electromagnetic compatibility

No inadmissible electromagnetic emissions occur if the installation instructions specific to the product are correctly observed.

The table below lists the results of measurements relating to the emissions and immunity to interference of MICROMASTER inverters.

The inverters were installed with shielded motor cables and shielded control cables in accordance with the directives.

EMC phenomenon Standard/test	Relevant criteria	Limit value
Emitted interference EN 61 800-3	Conducted via mains cable	150 kHz to 30 MHz Unfiltered devices, not tested. All devices with an internal/external filter: Depending on the type of filter and on the envisaged PDS installation: Category C1: Limit value complies with EN 55 011, Class B Category C2: Limit value complies with EN 55 011, Class A, Group 1. In addition, all devices with an internal/external filter comply with the limit value for category C3 installations. Limit value complies with EN 55 011, Class A, Group 2.
	Emitted by the drive	30 MHz to 1 GHz All devices. Limit value complies with EN 55 011, Class A, Group 1.
ESD immunity EN 61 000-4-2	ESD through air discharge ESD through contact discharge	Test severity level 3 Test severity level 3 8 kV 6 kV
Immunity to electrical fields EN 61 000-4-3	Electrical field applied to unit	Test severity level 3 80 MHz to 1 GHz 10 V/m
Immunity to burst interference EN 61 000-4-4	Applied to all cable terminations	Test severity level 4 4 kV
Surge immunity EN 61 000-4-5	Applied to mains cables	Test severity level 3 2 kV
Immunity to RFI emissions, conducted EN 61 000-4-6	Applied to mains, motor and control cables	Test severity level 3 0.15 MHz to 80 MHz 80 % AM (1 kHz) 10 V

UL listing



® and c® listed power conversion equipment of ® category NMMS, in accordance with UL508C.

® list number E121068 and E192450

For use in environments with pollution degree 2.

Also refer to the Internet at <http://www.ul.com>

Integration of drives into the SIMATIC S7 automation system with Drive ES

Drive ES Basic supports user-friendly start-up, service and diagnostics of all Siemens drives.

For integrated installation as a STEP 7 option, it is important to note the version of STEP 7 that is being used with regard to the ordering information.

Drive ES SIMATIC makes libraries available that contain SIMATIC function blocks so that the communication between the SIMATIC S7 CPU and the Siemens drive (e.g. MICROMASTER 4) can be reduced to simple parameterization. Drive ES SIMATIC replaces the software package DVA_S7 for all STEP 7 Versions 5.x and can also be installed and implemented as stand-alone software, i.e. without Drive ES Basic.

Contents of the package Drive ES SIMATIC:

- Communications software "USS protocol" for
 - SIMATIC S7-300 with CPUs with integrated DP interface (function block libraries DRVDPS7, POSMO)
 - SIMATIC S7-400 with CPUs with integral DP interface or with CP443-5 (function block library DRVDPS7, POSMO)
 - SIMATIC S7-300 with CP342-5 (function block library DRVDPS7C)
- Communications software "USS protocol" for
 - SIMATIC S7-200 with CPU 214/CPU 215/ CPU216 (driver program DRVUSS2 for programming tool STEP 7-Micro)
 - SIMATIC S7-300 with CP 340/341 and SIMATIC S7-400 with CP 441 (function block library DRVUSS7)

- STEP 7 slave object manager
 - For easy configuration of drives
 - For acyclic PROFIBUS DP communication with the drives
 - Support for converting DVA_S7 to Drive ES projects (from V5.1)
- SETUP program
 - For installing the software in the STEP 7 environment

Drive ES PCS7 provides a function block library complete with picture and control blocks that can be used to integrate a Siemens drive (e.g. MICROMASTER 4) based on a speed interface into the SIMATIC PCS7 process control system. Operation and monitoring of the drive is then possible from the Operator Station (OS) using the drive faceplates.

The PCS7 library can be implemented stand-alone, i.e. even without Drive ES Basic, under PCS7 Versions 5.0 and 5.1.

Content of the package Drive ES PCS7 (the PCS7 package can be used with the PCS7 Versions V5.0, V5.1 and V6.0):

- Function block library for SIMATIC PCS7
 - Picture and control blocks for SIMOVERT MASTERDRIVES VC and MC as well as MICROMASTER 3/ MIDIMASTER 3 and MICROMASTER 4
- STEP 7 slave object manager
 - For easy configuration of drives
 - For acyclic PROFIBUS DP communication with the drives
- SETUP program
 - For installing the software in the PCS7 environment.

Software package Drive ES Installation as an integrated option to STEP7 V5.2 and higher	Supply format	Documentation	Order No.
Drive ES Basic V5.3 *) single license	CD-ROM	Five standard languages	6SW1700-5JA00-3AA0
Drive ES Basic Upgrade *) from V5.x to V5.3 single license	CD-ROM	Five standard languages	6SW1700-5JA00-3AA4
Drive ES Basic V5.3 *) copy license (60 installations)	CD-ROM and copy license	Five standard languages	6SW1700-5JA00-3AA1
Drive ES SIMATIC V5.3 single license/runtime license	CD-ROM	Five standard languages	6SW1700-5JC00-3AA0
Drive ES SIMATIC Upgrade from V5.x to V5.3 single license	CD-ROM	Five standard languages	6SW1700-5JC00-3AA4
Drive ES SIMATIC V5.x copy license/runtime license	Product license only (without software and documentation)	Five standard languages	6SW1700-5JC00-1AC0
Drive ES PCS7 V5.2 single license	CD-ROM	Five standard languages	6SW1700-5JD00-2AA0
Drive ES PCS7 V6.0 single license/runtime license	CD-ROM	Five standard languages	6SW1700-6JD00-0AA0
Drive ES PCS7 Upgrade from V5.x to V6.0 single license	CD-ROM	Five standard languages	6SW1700-6JD00-0AA4
Drive ES PCS7 V5.x/V6.x copy license/runtime license	Product license only (without software and documentation)	Five standard languages	6SW1700-5JD00-1AC0

*) Drive ES Basic can also be installed stand-alone without STEP 7.

Software update service for Drive ES

A software update service can also be purchased for the Drive ES software. The user is automatically supplied with the current software, service packs and complete versions for one year after the date of ordering.

Duration of the update service: 1 year.

6 weeks before expiry, the customer and his Siemens contact will be informed in writing that the update service will automatically be extended by another year if it is not cancelled on the part of the customer.

The update service can only be ordered to customers who have previously purchased a complete version.

Software update service	Order No.
Drive ES Basic Update service for single license for copy license	6SW1700-0JA00-0AB2 6SW1700-0JA00-1AB2
Drive ES SIMATIC Update service for single license	6SW1700-0JC00-0AB2
Drive ES PCS7 Update service for single license	6SW1700-0JD00-0AB2

Drive technology for the chemicals industry



Even more so than in other sectors, drive technology and automation technology in the chemicals industry must comply with the most exacting safety standards in order to protect persons, machines and the environment. Our comprehensive drive portfolio – ranging from frequency inverters through distributed drive systems as far as gear motors, standard low-voltage motors and even tailor-made special versions – take these requirements into account.

You will find information about this on our industry site:

<http://www.ad.siemens.de/chemicals>



Example: Mounting plate to NAMUR standard based on MICROMASTER 440

Appendix

Demonstration case

SIDEMO demonstration case system

The SIDEMO range of modular demonstration case systems also includes cases for the MICROMASTER inverters.

The MICROMASTER demonstration cases can be operated on 230 V supplies on their own or together with other demonstration systems such as LOGO!, SIMATIC S7-200, SITOP DC-UPS.

The demonstration systems are fitted in dark blue transport cases (400 x 300 x 210 mm). The transport cases can be stacked.

If the MICROMASTER 420/440 demonstration case is expanded with a PROFIBUS module (not included in scope of supply of the case), it is also possible to demonstrate incorporation into TIA in combination with the SIMATIC S7-300 Compact and Touchpanel TP170B demonstration systems.



SIDEMO demonstration case	Order No.	Weight, approx. kg
MICROMASTER 410 • including OP operator panel	6AG1062-1AA08-0AA0	10
MICROMASTER 420 • including BOP operator panel	6AG1062-1AA02-0AA0	10
MICROMASTER 440 • including BOP operator panel	6AG1062-1AA02-1AA1	10
MICROMASTER 440 • including BOP operator panel • the motor is equipped with a load unit	6AG1062-1AA06-0AA0	10
MICROMASTER 440 • including BOP operator panel and pulse encoder evaluation module • the motor is equipped with an encoder and a load unit	6AG1062-1AA07-0AA0	10

Further information, e.g. **110 V versions**, is available on the Internet at: <http://www.siemens.de/sidemo>

Standard conversion factors: metric to US units

Unit	US to metric standard units	Metric to US standard units
Length	1 in. = 25.40 mm	1 mm = 0.03937 in.
	1 ft. = 30.48 cm	1 cm = 0.39370 in.
	1 yd. = 0.91 m	1 m = 3.28084 ft.
	1 mi. = 1.61 km	1 km = 0.62137 mi.
Temperature	°C = 5/9 (°F - 32)	°F = (9 x °C)/5 + 32
Weight	1 lbs = 0.454 kg	1 kg = 2.205 lbs
Torque	1 lb.ft. = 1.356 Nm	1 Nm = 0.738 lb.ft.
Power	1 hp = 0.746 kW	1 kW = 1.341 hp

Note:

For kW and hp specifications in the Selection and Ordering tables, we do not use calculated hp values but the corresponding standardized hp motor ratings.

Training



Because training is the key to your success

SITRAIN® – Siemens training for automation and industrial solutions – will be constantly by your side to help you find solutions for your tasks.

With training provided by the market leader in automation, plant installation and support, you can have complete confidence in any decisions you make, in particular concerning the optimum use of products and the efficient running of systems. You can rectify deficits in existing systems and rule out expensive planning errors right from the start.

All in all, this is a massive plus for your company, as you will benefit in terms of shorter start-up times, optimized plant sections, faster troubleshooting and reduced downtimes. The result? Profits go up and costs come down.

Top trainers

Our trainers are skilled specialists with extensive experience of training provision. The designers of our courses are directly involved in product development and forward their knowledge directly to our trainers.

A firm basis in practice

As our trainers have direct experience of practical applications, they are able to render their theoretical knowledge with real plausibility. However, as we all know that any theory has its gray areas, we prioritize practical exercises, and allocate up to half of the course program to them. This means that you can apply what you have learned immediately in everyday activities. We use state-of-the-art customized training equipment. Once you have completed your training with us, you will feel ready for anything.

Training variety

With a total of some 300 participant-based courses, we can provide training for the entire range of products and a large number of system solutions. Remote learning services, self-teach software and moderated on-line seminars complement our traditional training offer.

Customer proximity

We are never very far away. We have approximately 60 locations in Germany and a presence in 62 countries all over the world. Would you prefer individual training to taking part in one of our 300 courses? Our solution: We can customize our program to meet your personal requirements. Training takes place in our training centers or on your site.

The ideal combination: Blended learning

Blended learning combines a variety of teaching media and sequences. For example, a participant-based course in a training center can be ideally

combined with self-teach programs prior to or following completion. SITRAIN also uses moderated online learning to provide training live on the Internet at agreed times.

The combination is the key, because blended learning is able to communicate complex subjects and transfer knowledge on a networked basis. Additional benefit: Travel expenses and downtimes are reduced as training is no longer restricted to a specific time and place.

The international learning portal

Additional information is available on the Internet under: <http://www.siemens.com/sitrain>

All your learning options at a glance! Take your time to browse our international training package, call up all course dates online, use the available places indicator (updated daily) - and apply directly.

Alternatively, contact us directly for personal advice:

Training Office, Infoline Germany
Phone: +49 (0) 18 05-23 56 11
Fax: +49 (0) 18 05-23 56 12

Training Office, US
Phone: +1 800 241 4453
sitrain.registrar@sea.siemens.com

... and request a copy of our latest training catalog:

	Language	Order No.
ITC Catalog (paper version)	German	E86060-K6850-A101-B6
List of dates and prices including CD-ROM	German	E86060-P6850-A101-D2
Interactive training information system SITRAINonCD on CD-ROM	English/ German	E86060-D6850-A100-C4-7400
Overview of training worldwide	English/ German	E86060-K6899-A101-B5-7400

Overview of frequency inverters/converters for distributed I/O units: SIMATIC ET 200S FC

The SIMATIC ET 200S FC is a frequency inverter with a wide range of possibilities.

The table provides an overview of the features of this product. The complete range of products together with

ordering data, technical data and explanations are indicated in the IK PI catalog "Industrial Communication for

Automation and Drives" and in the Internet under:
<http://www.siemens.com/et200s-fc>

SIMATIC ET 200S FC	
Main features	"With its wide range of possibilities" , the ET 200S FC makes it possible for the distributed ET 200S system to be used for new applications in the area of drive technology, where infinite speed control of inductive motors is required. This frequency converter can handle simple drive tasks (frequency control) as well as complex tasks with vector control. Integrated safety functions enable drive solutions without high overheads, even in parts of an installation where potential hazards exist.
Rated outputs	750 W, 2.2 kW, 4.0 kW
Input voltage	3 AC 380 V to 480 V +10 % -15 %
Total module width	Control module + power unit 80 mm up to 750 W rated output, otherwise 145 mm
Mains frequency	47 to 63 Hz
Overload capacity	Overload current 1.5 x rated output current (i.e. 150% overload) for 60 s, cycle time 300 s Overload current 2 x rated output current (i.e. 200% overload) for 3 s, cycle time 300 s
Output frequency	0 Hz to 650 Hz
Pulse frequency	8 kHz (standard), 2 kHz to 16 kHz (in 2 kHz steps)
Skip frequency range	1, programmable
Efficiency	≥ 96 %
Interfaces	<ul style="list-style-type: none"> • PROFIBUS or PROFINET interface via the ET 200S backplane bus • Control of the integrated safety functions via PROFIsafe (PM-D F PROFIsafe) or terminals (PM-D F X1) • RS232 interface with USS protocol for start-up at PC with STARTER start-up software • Slot for an optional micro-memory card for uploading and downloading parameter settings • PTC/KTY84 interface for motor monitoring • Tachometer interface (Sub-D connector) for unipolar HTL incremental encoder
Standards complied with	UL, cUL, CE and C-tick, low-voltage directive 73/23/EEC, EMC directive 89/336/EEC
Functional safety	Control board with integrated safety functions in accordance with Category 3 of EN 954-1 or in accordance with SIL 2 of IEC 61508: <ul style="list-style-type: none"> • Safe stop • Safe braking ramp • Safely reduced speed The safety functions "Safely reduced speed" and "Safe braking ramp" are certified for encoderless induction motors – these safety functions are not approved for pull-through loads such as found in hoisting gear and unwinding units.
Degree of protection	IP20



SIMATIC ET 200S FC control boards



SIMATIC ET 200S FC power units

Overview of inverters – SINAMICS G110 chassis units

The SINAMICS G110 inverter chassis unit is a versatile drive. The table provides an overview of the features of this

product. The complete range of products together with ordering data, technical data and explanations are indicated

in the D 11.1 catalog “SINAMICS G110 Inverter Chassis Units” and in the Internet under:

<http://www.siemens.com/sinamics-g110>

SINAMICS G110	
Main features	As “a versatile drive for small outputs” , the frequency inverter of the SINAMICS G110 inverter chassis units can be used for a wide range of industrial drive applications with variable speeds. The especially compact SINAMICS G110 inverter works with voltage-frequency control (<i>V/f</i>) and is the ideal frequency inverter in the lower output and performance range of the SINAMICS family of products. The inverter is available in three frames for connection to single-phase power supply systems.
Output range	0.12 kW to 3.0 kW
Supply voltages	1 AC 200 V to 240 V, ±10 %
Network types	IT, TN, TT
Mains frequency	50/60 Hz
Output frequency	0 Hz to 650 Hz
Control method	<i>V/f</i> control, linear (<i>M~n</i>) <i>V/f</i> control, quadratic (<i>M~n²</i>) <i>V/f</i> control, programmable
Fixed frequencies	3, programmable
Skip frequency ranges	1, programmable
Digital inputs	3 programmable digital inputs 24 V DC
Analog input (for the analog version)	1 analog input for setpoints from 0 V to 10 V, scalable or usable as 4th digital input
Digital output	1 digital output 24 V DC
Communication interface (for USS version)	RS485 serial interface for operation with USS protocol
Software functions	<ul style="list-style-type: none"> • Automatic restart after interruption of operation due to supply failure • Jerk-free connection of inverter to rotating motor • Programmable ramp-up/ramp-down times • Ramp rounding
Protection functions	<ul style="list-style-type: none"> • Undervoltage • Overvoltage • Earth fault • Short-circuit • Stall prevention • <i>I²t</i> motor thermal protection • Inverter overtemperature • Motor overtemperature
Connectable motors	Asynchronous motors
Degree of protection	IP20
Type of cooling for ≤ 0.75 kW inverters > 0.75 kW inverters	Ribbed heat sink with convection cooling; version with flat heat sink also available Internal air cooling (integrated fan)
Standards complied with	CE, UL, cUL, c-tick



Examples
SINAMICS G110 inverter chassis units

Appendix

Overview of motors





Siemens motors are ideally matched to the MICROMASTER inverters. The table provides an overview of the most common types of motors from Siemens.

In addition to the motors listed in the table, explosion-proof motors, marine motors and combustion gas motors are also available.

Catalog M 11 contains the complete range of products with ordering data, technical details and explanations.

This catalog is suitable for IEC motors. For motors according to US standards (NEMA) please refer to:

<http://www.sea.siemens.com/motors>

Main characteristics	Squirrel-cage motors						
	Motors with gray cast iron casing			Motors with aluminium casing			
	1LG6	1LG4	1LA8	1LA9	1LA9	1LA7	1LA5
Efficiency class	 *)	 *)		 *)	EPACT	 *)	
Rating (4-pole)	18.5 – 200 kW	18.5 – 200 kW	250 – 1000 kW	0.06 – 30 kW	0.08 – 40 hp	0.06 – 15 kW	18.5 – 45 kW
Speeds	3000 rpm 1500 rpm 1000 rpm 750 rpm			3000 rpm 1500 rpm 1000 rpm	3600 rpm 1800 rpm 1200 rpm	3000 rpm 1500 rpm 1000 rpm 750 rpm	
Voltage (at 50 Hz if not specified otherwise)	230/400 V Δ/Υ 400/690 V Δ/Υ		400/690 V Δ/Υ	230/400 V Δ/Υ 400/690 V Δ/Υ	60 Hz 460 Δ Υ	230/400 V Δ/Υ 400/690 V Δ/Υ	
Size	180 – 315		315 – 450	56 – 200		56 – 160	180 – 225
Design	IM B3 IM B5 IM V1 IM B14 (Sizes 100 to 160) IM B35		IM B3 IM V1 IM B35	IM B3 IM B5 IM V1 IM B14 (Sizes 56 to 160) IM B35			
Casing	Gray cast iron			Aluminum			
Degree of protection	IP55 (IP65, IP56)		IP55 (IP56)	IP55 (IP65, IP56)			

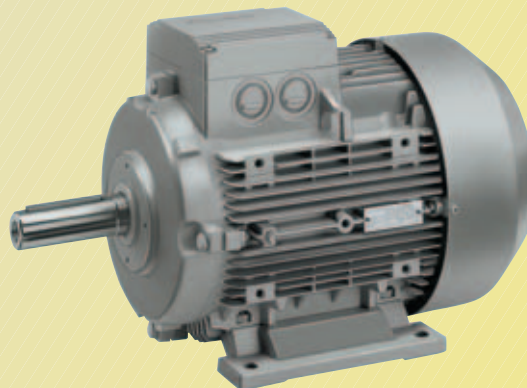

Example of 1 LA7 motor

*) 1.1 kW to 90 kW, 2-pole and 4-pole

Overview of distributed drive solutions · MICROMASTER 411/COMBIMASTER 411/Geared motors

The MICROMASTER 411/ COMBIMASTER 411 and geared motors from Siemens are available as distributed drive solutions. The table provides an overview of the features of these products.

The complete range of products together with ordering data, technical data and explanations are indicated in the catalogs DA 51.3 MICROMASTER – COMBIMASTER,

M15 Geared Motors and M15 News 2005. The latest information on MICROMASTER 411 and COMBIMASTER 411 as well as on geared motors is available in the Internet under:

<http://www.siemens.com/combimaster>
<http://www.siemens.com/gearedmotors>

Main features	MICROMASTER 411	COMBIMASTER 411	Geared motors				
	“The distributed inverter” for a wide range of drive applications - for simple individual applications from pumps and fans to multiple conveyor-belt drives in networked control systems.		Helical gears 2KG31, 2KG36, 2KG41, 2KG46	Flat gears 2KG32, 2KG42	Helical bevel gears 2KG33, 2KG43	Helical worm gears 2KG34	Worm gears 2KG35
Output range	0.37 kW to 3 kW		0.09 kW to 45 kW			0.09 kW to 7.5 kW	0.09 kW to 1.5 kW
Voltage range	3 AC 380 V to 480 V		230/400 V Δ/Y; 500 V Δ/Y; 400/690 V Δ/Y				
Frame sizes/ unit sizes	CS B CS C	71 – 100 90/100	63 – 225			63 – 132	63 – 90
Types of construction	–	IM B 3 IM B 5 IM V 1 (without protective roof) IM V 1 (with protective roof) IM B 14 (with normal flange) IM B 14 (with special flange) IM B 35	Footprint type of construction Flange type of construction	Footprint type of construction Flange type of construction Torque support			
Degree of protection	IP65	IP55	IP55 (IP65, IP56)				
Other technical features	<ul style="list-style-type: none"> V/f characteristic Multipoint characteristic (programmable V/f characteristic) FCC (flux current control) Internal PI controller 3 digital inputs 1 analog input 1 relay output Compound braking for controlled rapid braking NEW: ECOFAST versions with plug-in connectors for power-supply, communication interface and motor connections in order to enable fast and problem-free information exchange in applications where time is a critical factor. The ECOFAST versions are completely compatible with the ECOFAST technology systems. 		Housing made of aluminum or gray cast iron Torque 82 – 20000 Nm	Housing made of aluminum or gray cast iron Torque 150 – 20000 Nm	Housing made of aluminum or gray cast iron Torque 130 – 20000 Nm	Housing made of aluminum or gray cast iron Torque 120 – 1590 Nm	Housing made of die-cast aluminum Torque 50 – 185 Nm



Examples
MICROMASTER

Examples
COMBIMASTER



Examples
Geared motors

Appendix

Siemens Contacts Worldwide



At

<http://www.siemens.com/automation/partner>

you can find details of Siemens contact partners worldwide responsible for particular technologies.

You can obtain in most cases a contact partner for

- Technical Support,
- Spare parts/repairs,
- Service,
- Training,
- Sales or
- Consultation/engineering.

You start by selecting a

- Country,
- Product or
- Sector.

By further specifying the remaining criteria you will find exactly the right contact partner with his/her respective expertise.



A

A&D in the WWW



A detailed knowledge of the range of products and services available is essential when planning and configuring automation systems. It goes without saying that this information must always be fully up-to-date.

The Siemens Automation and Drives Group (A&D) has therefore built up a comprehensive range of information in the World Wide Web, which offers quick and easy access to all data required.

Under the address

<http://www.siemens.com/automation>

you will find everything you need to know about products, systems and services.

Product Selection Using the Interactive Catalog

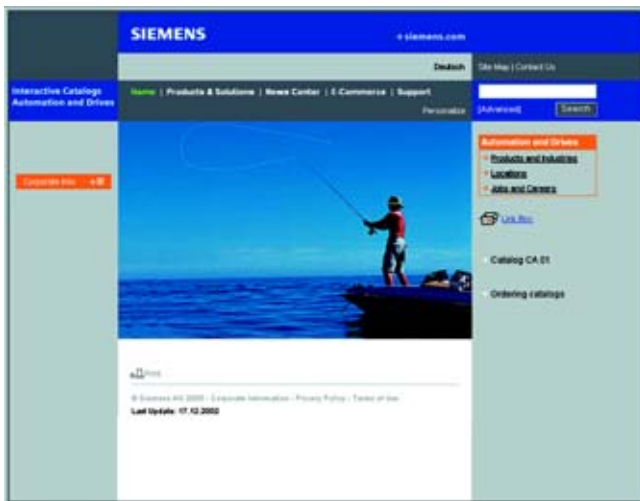

Detailed information together with convenient interactive functions:

The interactive catalog CA 01 covers more than 80,000 products and thus provides a full summary of the Siemens Automation and Drives product base.

Here you will find everything that you need to solve tasks in the fields of automation, switchgear, installation and drives. All information is linked into a user interface which is easy to work with and intuitive.

After selecting the product of your choice you can order at the press of a button, by fax or by online link.

Information on the interactive catalog CA 01 can be found in the Internet under

<http://www.siemens.com/automation/ca01>

or on CD-ROM or DVD.

Easy Shopping with the A&D Mall



The A&D Mall is the virtual department store of Siemens AG in the Internet. Here you have access to a huge range of products presented in electronic catalogs in an informative and attractive way.

Data transfer via EDIFACT allows the whole procedure from selection through ordering to tracking of the order to be carried out online via the Internet.

Numerous functions are available to support you.

For example, powerful search functions make it easy to find the required products, which can be immediately checked for availability. Customer-specific discounts and preparation of quotes can be carried out online as well as order tracking and tracing.

Please visit the A&D Mall on the Internet under:

<http://www.siemens.com/automation/mall>

Appendix



In the face of harsh competition you need optimum conditions to keep ahead all the time:

A strong starting position. A sophisticated strategy and team for the necessary support - in every phase.

Service & Support from Siemens provides this support with a complete range of different services for automation and drives.

In every phase: from planning and startup to maintenance and upgrading.

Our specialists know when and where to act to keep the productivity and cost-effectiveness of your system running in top form.

Configuration and Software Engineering



Support in configuring and developing with customer-oriented services from actual configuration to implementation of the automation project. ¹⁾

Service On Site



With Service On Site we offer services for startup and maintenance, essential for ensuring system availability.

In Germany
0180 50 50 444 ¹⁾

Online Support



The comprehensive information system available round the clock via Internet ranging from Product Support and Service & Support services to Support Tools in the Shop.

<http://www.siemens.com/automation/service&support>

Repairs and Spare Parts



In the operating phase of a machine or automation system we provide a comprehensive repair and spare parts service ensuring the highest degree of operating safety and reliability.

In Germany
0180 50 50 446 ¹⁾

Technical Support



Competent consulting in technical questions covering a wide range of customer-oriented services for all our products and systems.

Tel.: +49 (0)180 50 50 222
Fax: +49 (0)180 50 50 223

<http://www.siemens.com/automation/support-request>

Optimization and Upgrading



To enhance productivity and save costs in your project we offer high-quality services in optimization and upgrading. ¹⁾

Technical Consulting



Support in the planning and designing of your project from detailed actual-state analysis, target definition and consulting on product and system questions right to the creation of the automation solution. ¹⁾

¹⁾ For country-specific telephone numbers go to our Internet site at: <http://www.siemens.com/automation/service&support>

Knowledge Base on CD-ROM



For locations without online connections to the Internet there are excerpts of the free part of the information sources available on CD-ROM (Service & Support Knowledge Base). This CD-ROM contains all the latest product information at the time of production (FAQs, Downloads, Tips and Tricks, Updates) as well as general information on Service and Technical Support.

The CD-ROM also includes a full-text search and our Knowl-

edge Manager for targeted searches for solutions. The CD-ROM will be updated every 4 months.

Just the same as our online offer in the Internet, the Service & Support Knowledge Base on CD comes complete in 5 languages (German, English, French, Italian, Spanish).

You can order the **Service & Support Knowledge Base CD** from your Siemens contact.

Order no. **6ZB5310-0EP30-0BA2**

Orders via the Internet (with Automation Value Card or credit card) at:

<http://www.siemens.com/automation/service&support>

in the Shop domain.

Automation Value Card



Small card - great support

The Automation Value Card is an integral component of the comprehensive service concept with which Siemens Automation and Drives will accompany you in each phase of your automation project.

It doesn't matter whether you want just specific services from our Technical Support or want to purchase high-quality Support Tools in our Online Shop, you can always pay with your Automation Value Card. No invoicing, transparent and safe. With your personal card number and associated PIN you can view the state of your account and all transactions at any time.

Services on card. This is how it's done.

Card number and PIN are on the back of the Automation Value Card. When delivered, the PIN is covered by a scratch field, guaranteeing that the full credit is on the card.

By entering the card number and PIN you have full access to the Service & Support services being offered. The charge for the services procured is debited from the credits on your Automation Value Card.

All the services offered are marked in currency-neutral credits, so you can use the Automation Value Card worldwide.

Automation Value Card order numbers

Credits	Order no.
200	6ES7 997-0BA00-0XA0
500	6ES7 997-0BB00-0XA0
1000	6ES7 997-0BC00-0XA0
10000	6ES7 997-0BG00-0XA0

Detailed information on the services offered is available on our Internet site at:

<http://www.siemens.com/automation/service&support>

Service & Support à la Card: Examples

Technical Support

"Priority"	Priority processing for urgent cases
"24 h"	Availability round the clock
"Extended"	Technical consulting for complex questions

Support Tools in the Support Shop

"System Utilities"	Tools that can be used directly for configuration, analysis and testing
"Applications"	Complete topic solutions including ready-tested software
"Functions & Samples"	Adaptable blocks for accelerating your developments

Subject index

MICROMASTER

	410	420	430	440
	Page	Page	Page	Page
A				
AAOP (operator panel)	-	2/16	-	4/22
AOP (operator panel)	-	2/16	-	4/22
Applications	1/2	2/2	3/2	4/2
Assignment table for options	0/8	0/8	0/8	0/8
Automation Value Card	A/17	A/17	A/17	A/17
B				
BOP (operator panel)	-	2/16	-	4/22
BOP-2 (operator panel)	-	-	3/16	-
Brake resistor (option)	-	-	-	4/17
C				
CANopen module	-	2/16	3/16	4/22
CE marking	A/4	A/4	A/4	A/4
Certificates	A/2	A/2	A/2	A/2
Chokes (options)	1/8	2/13	3/14	4/17
Circuit diagrams	1/4	2/4	3/4	4/4
Circuit-breaker (option)	1/9	2/14	3/14	4/18
COMBIMASTER 411 (overview)	A/13	A/13	A/13	A/13
Communications modules	-	2/16	3/16	4/22
Compliance with standards	A/4	A/4	A/4	A/4
Conditions of sale and delivery	A/20	A/20	A/20	A/20
D				
Demonstration case	A/8	A/8	A/8	A/8
Derating data	1/6	2/7	3/7	4/7
Description (inverter)	1/2	2/2	3/2	4/2
Description (options)	1/8	2/9	3/10	4/12
Design	1/2	2/2	3/2	4/2
DeviceNet module (option)	-	2/16	3/16	4/22
Dimension drawings	1/10	2/18	3/19	4/26
Docu pack	-	2/17	3/18	4/25
Documentation	1/9	2/17	3/18	4/25
Drive ES	A/6	A/6	A/6	A/6
Drive ES software	A/6	A/6	A/6	A/6
DriveMonitor	1/9	2/15	3/16	4/22
E				
Electromagnetic compatibility	A/5	A/5	A/5	A/5
EMC filter (option)	1/8	2/12	3/14	4/16
Environment, resources and recycling	A/2	A/2	A/2	A/2
Export regulations	A/20	A/20	A/20	A/20
F				
Features	1/3	2/3	3/3	4/3
Filter (option)	1/8	2/12	3/14	4/16
Fuses (options)	1/9	2/14	3/14	4/18
G				
Geared motors (overview)	A/13	A/13	A/13	A/13
General circuit diagram	1/4	2/4	3/4	4/4
Getting Started Guide	1/9	2/17	3/18	4/25
I				
Installation height (derating)	1/7	2/7	3/8	4/8
Integration with Drive ES	A/6	A/6	A/6	A/6
International standards	1/2	2/2	3/2	4/2
Internet (online services)	A/15	A/15	A/15	A/15
L				
LC filter	-	2/13	3/14	4/17
Line commutating chokes (option)	1/8	2/13	3/14	4/16

MICROMASTER

	410	420	430	440
	Page	Page	Page	Page
M				
Main characteristics	1/2	2/2	3/2	4/2
Mechanical features	1/3	2/3	3/3	4/3
MICROMASTER 411 (overview)	A/13	A/13	A/13	A/13
Motors (overview)	A/12	A/12	A/12	A/12
N				
Notes on ordering	A/19	A/19	A/19	A/19
O				
Online services	A/15	A/15	A/15	A/15
OP (operator panel)	1/9	-	-	-
Operating instructions	1/9	2/17	3/18	4/25
Operating temperature (derating)	-	2/7	3/7	4/8
Operator panels	1/9	2/16	3/16	4/22
Options	1/8	2/9	3/10	4/12
Ordering data (inverter)	1/7	2/8	3/9	4/9
Ordering data (options)	1/8	2/12	3/14	4/16
Output chokes (option)	-	2/13	3/14	4/17
Overview	0/6	0/6	0/7	0/7
P				
Parameter list	1/9	2/17	3/18	4/25
Performance features	1/3	2/3	3/3	4/3
PROFIBUS module (option)	-	2/16	3/16	4/22
Protection features	1/3	2/3	3/3	4/3
Pulse encoder evaluation module (option)	-	-	-	4/22
Pulse frequency (derating)	1/6	2/7	3/7	4/7
S				
Selection and ordering data (inverter)	1/7	2/8	3/9	4/9
Selection and ordering data (options)	1/8	2/11	3/14	4/16
Selection guide	0/6	0/6	0/7	0/7
Service and support	A/16	A/16	A/16	A/16
SIDEMO (demonstration case system)	A/8	A/8	A/8	A/8
Siemens contacts worldwide	A/14	A/14	A/14	A/14
Sinusoidal filter	-	-	3/14	4/17
STARTER	1/9	2/16	3/16	4/22
Start-up tools	1/9	2/15	3/16	4/22
Support	A/16	A/16	A/16	A/16
T				
Technical data (inverter)	1/6	2/6	3/6	4/6
Technical data (options)	-	2/10	3/10	4/12
Terminal connection diagram	1/5	2/5	3/5	4/5
Terminal connection plates (option)	-	2/14	3/14	4/18
Training	A/9	A/9	A/9	A/9
U				
UL listing	A/5	A/5	A/5	A/5
Update service for Drive ES	A/7	A/7	A/7	A/7
V				
Variant dependent options	1/8	2/12	3/14	4/16
Variant independent options	1/9	2/16	3/16	4/22

Order No. index

Notes on ordering

MICROMASTER

Versions/variants

The last digit of the complete Order No. for the inverters represents the release version.

When ordering, a different digit from the one specified may be present as a result of further technical development.

	410	420	430	440
	Page	Page	Page	Page
3NA3...	1/8	2/14	3/14, 3/15	4/18, 4/20
3NE1...	-	-	3/14, 3/15	4/18, 4/20
3RV10..	1/8	2/14	3/14, 3/15	4/18, 4/20
3VL.....	-	-	3/14, 3/15	4/18, 4/20
6AG1062-1AA..	A/8	A/8	-	A/8
6ES7997-0B...	A/17	A/17	A/17	A/17
6GK1500-0FC00	-	2/16	3/16	4/22
6SE6400-0AP00-0AA1	-	2/16	-	4/22
6SE6400-0AP00-0AB0	-	2/16	-	4/22
6SE6400-0BE00-0AA0	-	-	3/16	-
6SE6400-0BP00-0AA0	-	2/16	-	4/22
6SE6400-0DR00-0AA0	1/9	-	-	-
6SE6400-0EN00-0AA0	-	-	-	4/22
6SE6400-0GP00-0.A0	-	2/14	3/14	4/18, 4/19
6SE6400-0MD00-0AA0	-	2/16	-	4/22
6SE6400-0P.00-0AA0	1/9	2/16	3/16	4/22
6SE6400-0SP00-0AA0	1/9	-	-	-
6SE6400-1CB00-0AA0	-	2/16	3/16	4/22
6SE6400-1DN00-0AA0	-	2/16	3/16	4/22
6SE6400-1P.00-0AA0	-	2/16	3/16	4/22
6SE6400-2FA0.	-	2/12	-	4/16
6SE6400-2FB0.	-	2/12	-	4/16
6SE6400-2FLO.	1/8	2/13	-	4/16
6SE6400-2FS0.	-	2/12	3/15	4/19
6SE6400-3CC..	1/8	2/13	3/14, 3/15	4/16, 4/19
6SE6400-3TC..	-	2/13	3/14, 3/15	4/17, 4/19
6SE6400-3TD..	-	2/13	3/14, 3/15	4/17, 4/19
6SE6400-4B...	-	-	-	4/17, 4/19
6SE6400-5....	1/9	2/17	3/18	4/25
6SE6410-2BB..	1/7	-	-	-
6SE6410-2UA..	1/7	-	-	-
6SE6410-2UB..	1/7	-	-	-
6SE6420-2AB..	-	2/8	-	-
6SE6420-2AC..	-	2/8	-	-
6SE6420-2AD..	-	2/8	-	-
6SE6420-2UC..	-	2/8	-	-
6SE6420-2UD..	-	2/8	-	-
6SE6430-2AD..	-	-	3/9	-
6SE6430-2UD..	-	-	3/9	-
6SE6440-2AB..	-	-	-	4/11
6SE6440-2AC..	-	-	-	4/11
6SE6440-2AD..	-	-	-	4/11
6SE6440-2UC..	-	-	-	4/9
6SE6440-2UD..	-	-	-	4/9
6SE6440-2UE..	-	-	-	4/10
6SL3000-0BE3.	-	-	3/14	4/16
6SL3000-0CE3.	-	-	3/14	4/17
6SL3000-2BE..	-	-	3/14	4/17
6SL3000-2CE..	-	-	3/14	4/16
6SL3072-0AA0.	1/9	2/16	3/16	4/22
6SW1700-0J...	A/7	A/7	A/7	A/7
6SW1700-5J...	A/6	A/6	A/6	A/6
6ZB5310-0EP30-0BA2	A/17	A/17	A/17	A/17
6ZB5310-0K...	A/20	A/20	A/20	A/20

Appendix

Terms and Conditions of Sale and Delivery

By using this catalog you can acquire hardware and software products described therein from the Siemens AG subject to the following terms. Please note! The scope, the quality and the conditions for supplies and services, including software products, by any Siemens entity having a registered office outside of Germany, shall be subject exclusively to the General Terms and Conditions of the respective Siemens entity.

For customers with a seat or registered office in the Federal Republic of Germany

The "General Terms of Payment" as well as the "General Conditions for the Supply of Products and Services of the Electrical and Electronics Industry" shall apply.

For software products, the "General License Conditions for Software Products for Automation and Drives for Customers with a Seat or registered Office in Germany" shall apply.

For customers with a seat or registered office outside of Germany

The "General Terms of Payment" as well as the "General Conditions for Supplies of Siemens Automation and Drives for Customers with a Seat or registered Office outside of Germany" shall apply.

For software products, the "General License Conditions for Software Products for Automation and Drives for Customers with a Seat or registered Office outside of Germany" shall apply.

General

The prices are in € (Euro) ex works, exclusive packaging.

The sales tax (value added tax) is not included in the prices. It shall be debited separately at the respective rate according to the applicable legal regulations.

In addition to the prices of products which include silver, plump, aluminum and/or copper, surcharges may be calculated if the respective limits of the notes are exceeded. The respective note (e.g. source: German newspaper "Handesblatt" in category "deutsche Edelmetalle" and "Metallverarbeiter") for silver ("verarbeitetes Silber"), plump ("Blei in Kabeln"), aluminum ("Aluminium in Kabeln") and copper ("Elektrolytkupfer", "DEL-Notiz") respectively, of the day the order or rather the on call order is received, is decisive for the calculation of the surcharges.

Surcharges of copper shall be calculated for Drives at a note ("DEL-Notiz") above EUR 225,00 / 100 Kg and for chokes / transformers above EUR 150,00 / 100 kg.

Surcharges shall be charged based on the quantities of the materials which are contained in the relevant products.

Prices are subject to change without prior notice. We will debit the prices valid at the time of delivery.

The dimensions are in mm. Illustrations are not binding.

Insofar as there are no remarks on the corresponding pages, - especially with regard to data, dimensions and weights given - these are subject to change without prior notice.

Comprehensive Terms and Conditions of Sale and Delivery are available free of charge from your local Siemens business office under the following Order Nos.:

- 6ZB5310-0KR30-0BA0
(for customers based in the Federal Republic of Germany)
- 6ZB5310-0KS53-0BA0
(for customers based outside of the Federal Republic of Germany)

or download them from the Internet:

<http://www.siemens.com/automation/mall>
(Germany: A&D Mall Online-Help System)

Export regulations

The products listed in this catalog / price list may be subject to European / German and/or US export regulations.

Therefore, any export requiring a license is subject to approval by the competent authorities.

According to current provisions, the following export regulations must be observed with respect to the products featured in this catalog / price list:

AL	Number of the <u>German Export List</u> . Products marked other than "N" require an export license. In the case of software products, the export designations of the relevant data medium must also be generally adhered to. Goods labeled with an " <u>AL not equal to N</u> " are subject to a European or German export authorization when being exported out of the EU.
ECCN	<u>Export Control Classification Number</u> . Products marked other than "N" are subject to a reexport license to specific countries. In the case of software products, the export designations of the relevant data medium must also be generally adhered to. Goods labeled with an " <u>ECCN not equal to N</u> " are subject to a US re-export authorization.

Even without a label or with an "AL: N" or "ECCN: N", authorization may be required due to the final destination and purpose for which the goods are to be used.

The deciding factors are the AL or ECCN export authorization indicated on order confirmations, delivery notes and invoices.

Errors excepted and subject to change without prior notice.

A&D/M/J/En 17.03.05

Order No.: **E86060-K5151-A121-A5-7600**
Printed in Germany
KG K 1005 30.0 E 120 En/622153

Further information can be obtained from our branch offices listed in the appendix or at www.siemens.com/automation/partner

Automation and Drives	<i>Catalog</i>		
Interactive catalog on CD-ROM			
• The Offline Mall of Automation and Drives	CA 01		
Automation Systems for Machine Tools			
SINUMERIK & SIMODRIVE	NC 60		
Drive Systems			
<u>Variable-Speed Drives</u>			
SINAMICS G130 Drive Converter Chassis Units, SINAMICS G150 Drive Converter Cabinet Units	D 11		
SINAMICS G110 Inverter Chassis Units	D 11.1		
SINAMICS S120 Servo Control Drive System	D 21.2		
SINAMICS S150 Drive Converter Cabinet Units	D 21.3		
DC Motors	DA 12		
SIMOREG DC MASTER 6RA70 Digital Chassis Converters	DA 21.1		
SIMOREG K 6RA22 Analog Chassis Converters	DA 21.2		
SIMOREG DC MASTER 6RM70 Digital Converter Cabinet Units	DA 22		
SIMOVERT PM Modular Converter Systems	DA 45		
SIEMOSYN Motors	DA 48		
MICROMASTER 410/420/430/440 Inverters	DA 51.2		
MICROMASTER 411/COMBIMASTER 411	DA 51.3		
SIMOVERT MV Medium-Voltage Drives	DA 63		
SIMOVERT MASTERDRIVES Vector Control	DA 65.10		
SIMOVERT MASTERDRIVES Motion Control	DA 65.11		
Synchronous and asynchronous servomotors for SIMOVERT MASTERDRIVES	DA 65.3		
SIMODRIVE 611 universal and POSMO	DA 65.4		
<u>Low-Voltage Three-Phase-Motors</u>			
Squirrel-Cage Motors, Totally Enclosed, Fan-Cooled	M 11		
<u>Automation Systems for Machine Tools SIMODRIVE</u>	NC 60		
• Main Spindle Motors			
• Feed Motors			
• Converter Systems SIMODRIVE 611/POSMO			
<u>Drive and Control Components for Hoisting Equipment</u>	HE 1		
Electrical Installation Technology			
ALPHA Small Distribution Boards and Distribution Boards	ETA 1		
<i>PDF: ALPHA 8HP Molded-Plastic Distribution System</i>	ETA 3		
ALPHA FIX Terminal Blocks	ETA 5		
BETA Modular Installation Devices	ET B1		
DELTA Switches and Outlets	ET D1		
GAMMA Building Management Systems	ET G1		
Factory Automation Sensors	FS 10		
Human Machine Interface Systems SIMATIC HMI	ST 80		
Industrial Communication for Automation and Drives	IK PI		
Low-Voltage Controls and Distribution	<i>Catalog</i>		
Low-Voltage Switchgear – Controlgear for Industry	LV 10		
Power Distribution – Products and Systems for Low-Voltage Power Distribution	LV 30		
SIDAC reactors and filters	LV 60		
SIVACON 8PS Busbar trunking systems CD, BD01, BD2 up to 1250 A	LV 70		
Low-Voltage Controlgear, Switchgear and Systems	LV 90		
Motion Control System SIMOTION	PM 10		
Process Instrumentation and Analytics			
Field Instruments for Process Automation	FI 01		
Measuring Instruments for Pressure, Differential Pressure, Flow, Level and Temperature, Positioners and Liquid Meters			
<i>PDF: Indicators for panel mounting</i>	MP 12		
SIREC Recorders and Accessories	MP 20		
SIPART, Controllers and Software	MP 31		
SIWAREX Weighing Systems	WT 01		
Continuous Weighing and Process Protection	WT 02		
Gas Analysis Equipment for the Process Industry	PA 10		
<i>PDF: Process Analytics, Components for the System Integration</i>	PA 11		
SIPAN Liquid Analysis	PA 20		
SIMATIC Industrial Automation Systems			
SIMATIC PCS Process Control System	ST 45		
<i>PDF: SIMATIC S5/505 Automation Systems</i>	ST 50		
Products for Totally Integrated Automation and Micro Automation	ST 70		
SIMATIC PCS 7 Process Control System	ST PCS 7		
<i>PDF: Add-ons for the SIMATIC PCS 7 Process Control System</i>	ST PCS 7.A		
pc-based Automation	ST PC		
SIMATIC Control Systems	ST DA		
SIPOS Electric Actuators			
Electric Rotary, Linear and Part-turn Actuators	MP 35		
Electric Rotary Actuators for Nuclear Plants	MP 35.1/2		
Systems Engineering			
Power supplies SITOP power	KT 10.1		
System cabling SIMATIC TOP connect	KT 10.2		
System Solutions			
Applications and Products for Industry are part of the interactive catalog CA 01			
TELEPERM M Process Control System			
<i>PDF: AS 488/TM automation systems</i>	PLT 112		

PDF: These catalogs are only available as pdf files.



The information provided in this catalog contains descriptions or characteristics of performance which in case of actual use do not always apply as described or which may change as a result of further development of the products. An obligation to provide the respective characteristics shall only exist if expressly agreed in the terms of contract. Availability and technical specifications are subject to change without notice.

ACP&D Limited

86 Rose Hill Road,
Ashton-under-Lyne,
Lancashire,
England,
OL6 8YF.

Tel: +44 (0)161 343 1884
Fax: +44 (0)161 343 7773
e-mail: sales@acpd.co.uk
Websites: www.acpd.com &
www.acpd.co.uk



Order No. E86060-K5151-A121-A5-7600

SIEMENS

MICROMASTER 410/420/430/440 Inverters

Catalog DA 51.2 • 2005/2006