

ES3 - EUROSTEP3



FEATURES:

Stepping motor drive, power supply from 25 to 85 Vdc, current up to 7A.
NPN/PNP optoisolated inputs and outputs compatibles with TTL (0-5VDC) or 0-24VDC level.

POWER SUPPLY:

DEFINITIONS

- Vdc nom:** Suggested nominal voltage value with unstabilized source
Vdc max: Maximum dc working voltage of the drive. Above such value, maximum voltage protection occurs, and drive working is inhibited
Vdc min: Minimum dc working voltage of the drive. Below such value, minimum voltage protection occurs, and drive working is inhibited
I max: Maximum phase current
I min: Minimum phase current

EUROSTEP		VALUES
Vdc nom.	[V]	From 25 to 85
Vdc max.	[V]	90
Vdc min.	[V]	20
I max.	[A]	7
I min.	[A]	1
Step Input (max.)	[kHz]	80
Working temperature	[°C]	0-55

MECHANICAL DIMENSIONS:

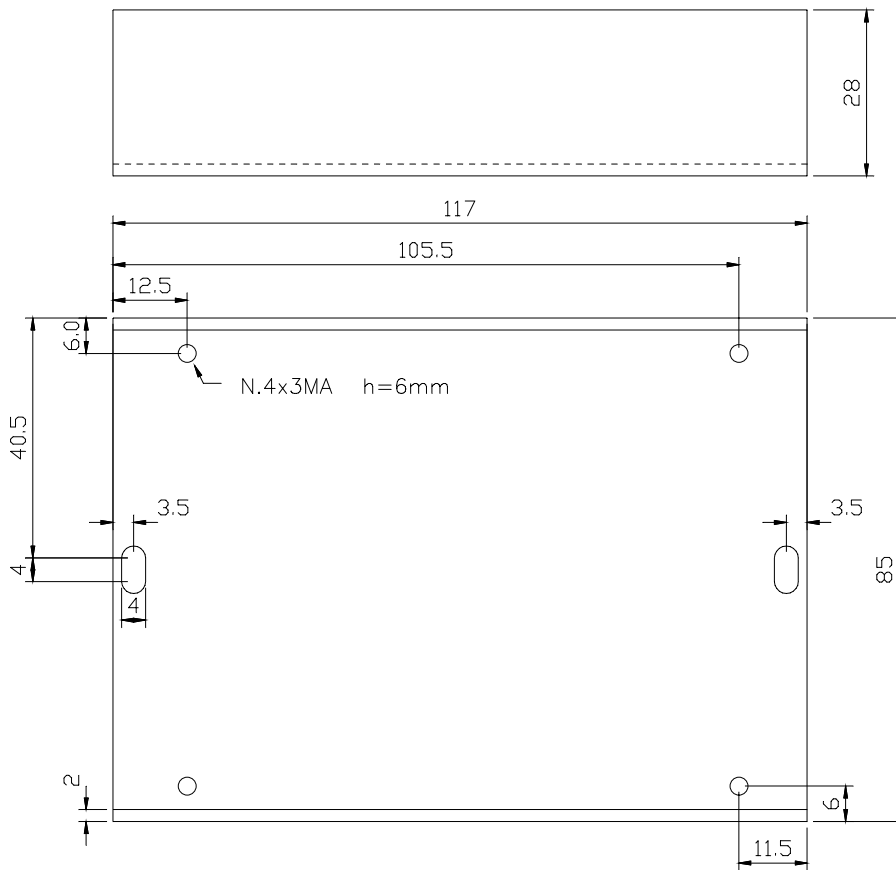

LAYOUT:

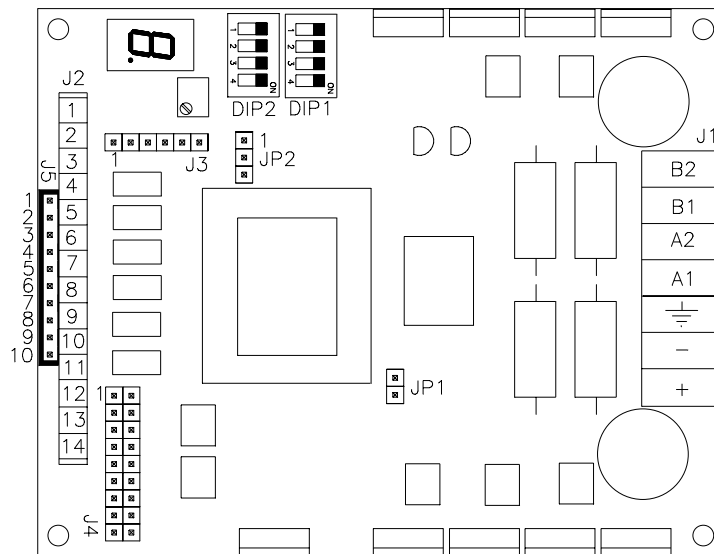

PROTECTION AND ERROR DISPLAY

Drive is provided with protection against over-temperature, over-voltage, under-voltage, short-circuits among outputs and also among outputs and the positive power pole. If one of the mentioned conditions occurs, drive disables the power bridge and shows an error condition on the display.

- 'o' - Power supply overvoltage (Vdc max)
- 'u' - Power supply undervoltage (Vdc min)
- 't' - Thermic protection event occurred
- 'c' - Overcurrent protection event occurred
- 'd' - Drive disabled (input ENABLE/DISABLE active)

If drive is ready, display shows the letter 'r' (ready).

INPUTS:

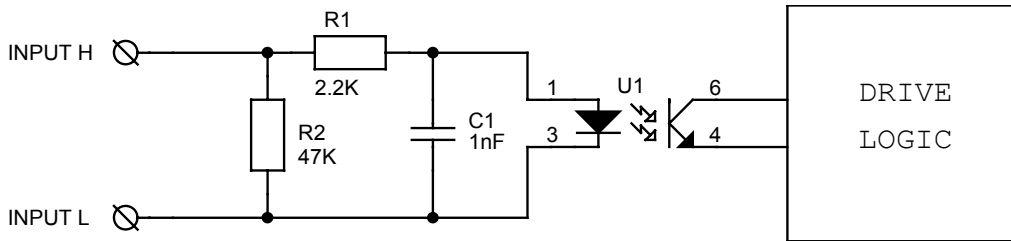

SIGNAL	FUNCTION
STEP-IN J2-7(L), J2-8(H)	The motor make a step at the HIGH-LOW signal transition. Best is a square wave with 50% duty-cycle. The absence of this signal for 0.5 seconds determines the intervention of the automatic current reduction (stand-by).
DIRECTION J2-5(L), J2-6(H)	Set the motor rotation direction. Signal must be stable at least 100 microseconds before and 100 after the STEP IN transition.
CURR. RED. J2-1(L), J2-1(H)	Reduce motor current. Percentage of reduction is selectable with DIP2: DIP2-1 = ON → reduct to 25% of setting current DIP2-1 = OFF → reduct to 50% of setting current
ENABLE/ DISABLE J2-3(L), J2-4(H)	When this signal is used, the drive is inhibited by cutting off the current flowing through the motor. You can use this input as ENABLE or DISABLE, select function with JP2: JP2 Inserted in 1-2 pins → DISABLE: When input is active motor current =0. JP2 Inserted in 2-3 pins → ENABLE: When input is not active motor current=0.

OUTPUTS:

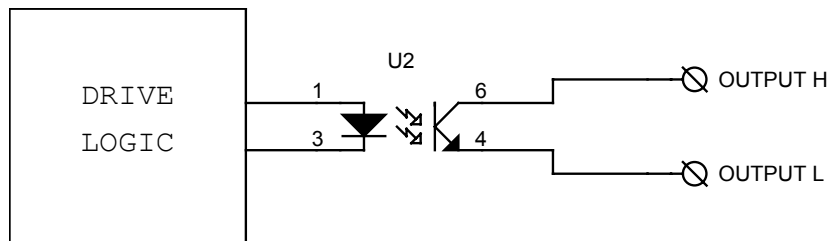

SIGNAL	FUNCTION
OUT1 J2-9(L), J2-10(H)	STEP OUT : Every input step generates an output step (can be used as a 'STEP -IN' for another drive) (maximum current 5 mA)
DRIVE-READY J2-11(L), J2-12(H)	DRIVER-READY Drive fault : Output disable (Low level) Drive ready : Output enabled (High level) (maximum current 5 mA)

MOTOR CURRENT REGULATION:

For setting current proceed as follows:

- Set DIP2-4 to ON (current regulation mode).
- Turn RV1 trimmer until display shows the required current (CW to increase).
- Set DIP2-4 to OFF (Run mode).

Table for setting current values and relating values shown on the display of drive:

- 1 = 1 A
- 1. = 1.5 A
- .
- .
- 7 = 7 A

RESOLUTION SETTINGS:

Resolution setting through DIP-SWITCHES:

DIP1-1	DIP1-2	DIP1-3	DIP1-4	STEPS/TOUR
OFF	OFF	OFF	OFF	200 step/rev. (full step)
ON	OFF	OFF	OFF	400 step/rev. (1 / 2 of step)
OFF	ON	OFF	OFF	800 step/rev. (1 / 4 of step)
ON	ON	OFF	OFF	1600 step/rev. (1 / 8 of step)
OFF	OFF	ON	OFF	3200 step/rev. (1 / 16 of step)
OFF	OFF	OFF	ON	500 step/rev. (1 / 2.5 of step)
ON	OFF	OFF	ON	1000 step/rev. (1 / 5 of step)
OFF	ON	OFF	ON	2000 step/rev. (1 / 10 of step)
ON	ON	OFF	ON	4000 step/rev. (1 / 20 of step)

MOTOR RESONANCE REDUCTION:

This drive is provided with an innovative system to reduce motor resonance. To active this function set DIP2-3 ON, to disabile set DIP2-3 OFF.

AUTOMATIC CURRENT REDUCTION WHEN MOTOR IS STOPPED:

The motor current is automatically reduced when motor is stopped. To change reduction value set DIP2-1:

DIP2-1 = ON → reduct to 25% of setting current

DIP2-1 = OFF → reduct to 50% of setting current

WIRING DIAGRAM

PNP INPUTS AND OUTPUTS:

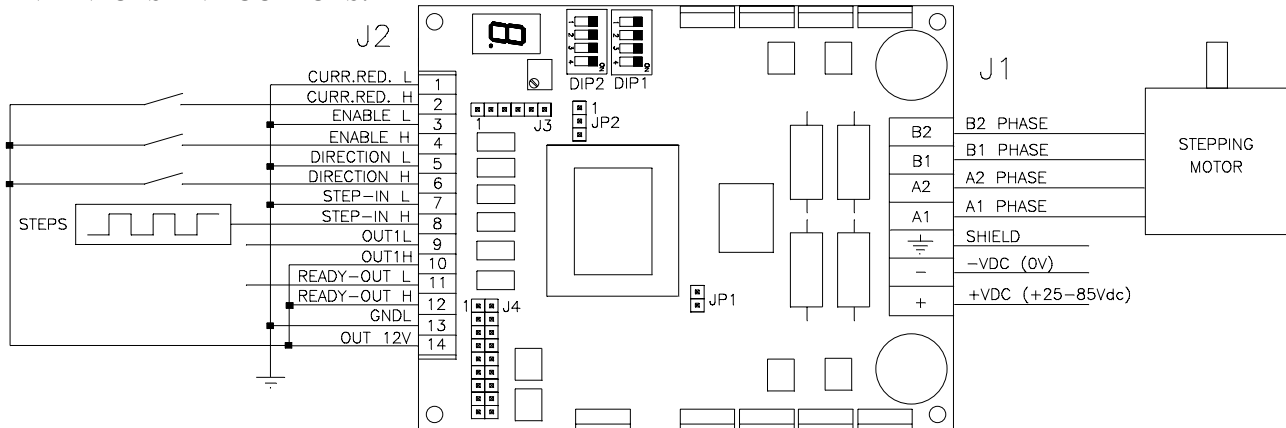

In this diagram is used internal +12V but you can use an external power suppli from 5 to 24 Vdc.

NPN INPUTS AND OUTPUTS:

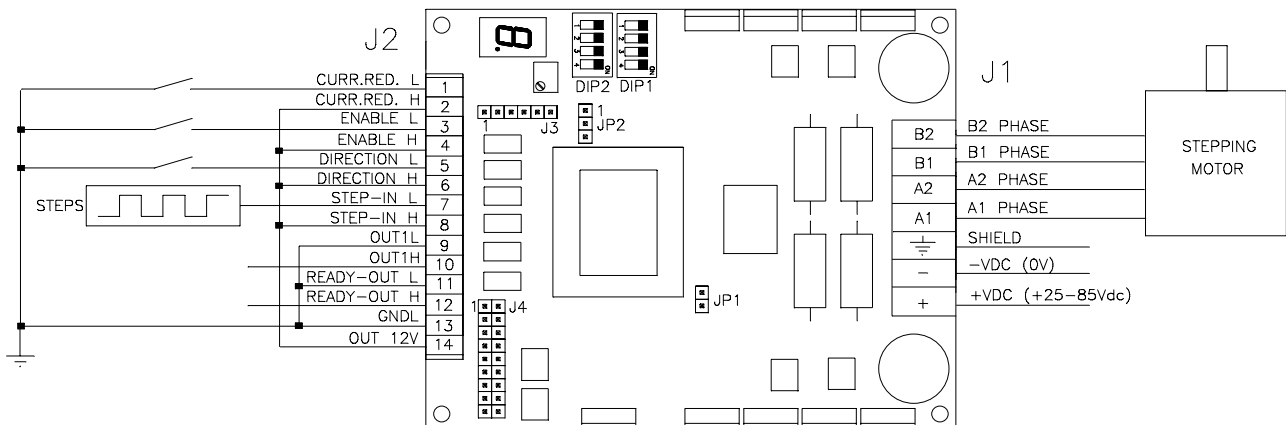

In this diagram is used internal +12V but you can use an external power suppli from 5 to 24 Vdc.

ACP&D Limited
Units 6 & 9A,
Charlestown Industrial Estate,
Robinson Street,
Ashton-under-Lyne,
Lancashire, OL6 8NS.

Tel: +44 (0)161 343 1884
Fax: +44 (0)161 339 0650
e-mail: sales@acpd.co.uk
Websites: www.acpd.com &
www.acpd.co.uk

