

MICRO-2

Stepping motor drive



Low cost drive for high precision applications (2.4A, 27VAC)

The **MICRO-2** stepping motor drive is a very compact design and offers a low-cost solution for small 2-phase stepping motor and actuator applications.

Supplied in a metal 'open' chassis design the **MICRO-2** can be easily and readily incorporated into existing control cabinets. The connectors are specially designed to enable quick connection without special tooling thus minimizing installation time.

The drive utilizes step & direction outputs for the customers control system. The adjustability of the output current from 0.1A to 2.4A makes it ideally suited even for the smallest 2-phase stepping motor. With it's ability to input an AC voltage supply (15 to 27VAC) it is ideal for applications requiring

multi axes control as an AC supply is normally readily available requiring simply a transformer to arrive at the required input voltage to the **MICRO-2**. The current input is adjusted via a 'trim pot' (RV1) located on the unit's printed circuit board.

A LED mounted onto the printed circuit board of the **MICRO-2** allows the user to see when the unit is powered up.

As well as the **MICRO-2** we can deliver the following accessories:

S6100 and S6500 range of 2-phase stepping motors; S7200 range of linear actuators; power supplies; and cables.

Features:

- Voltage supply: 15-27 VAC .
- Stepping motor output current: 2.4A.
- Available current adjustment range: 0.1A - 2.4A.
- Opto-isolated inputs
- Automatic current reduction when motor is stationary.
- Thermal protection.
- Full / half step operation.

DIP switch settings:

- | | |
|------------------|-------------------------------|
| 1 _{on} | full step |
| 1 _{off} | Half-step |
| 2 | Not used |
| 3 | Not used |
| 4 _{on} | Current reduction activated |
| 4 _{off} | Current reduction deactivated |

Dimensions:

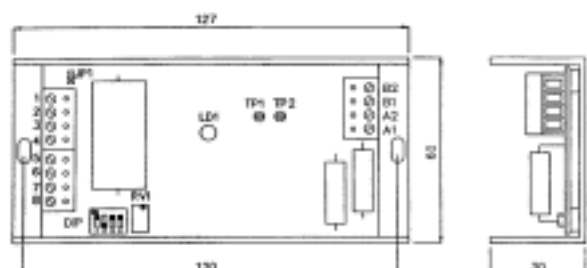

Technical characteristics

Connections:

Pin 1: AC input: 15 to 27VAC +/- 10%
 Pin 2: AC input: 15 to 27VAC +/- 10%
 Pin 3: Ground
 Pin 4: PNP version: Internal ground when jumper JP1 'closed'; customer's external ground when jumper JP1 'open'.
NPN version: When jumper JP1 'closed', output is +12VDC, 100mA; when jumper JP1 'open' an external DC voltage is required to be supplied by the customer (DC voltage range: +4.6 to 30VDC).

Pin 5: Deactivation
 Pin 6: Direction of rotation
 Pin 7: Clock input
 Pin 8: PNP version: Auxiliary +12VDC, 100mA output.
NPN version: Not used
 Pin A1: Motor phase A1
 Pin A2: Motor phase A2
 Pin B1: Motor phase B1
 Pin B2: Motor phase B2

Connection diagram:

PNP version (Micro-2-PS1)

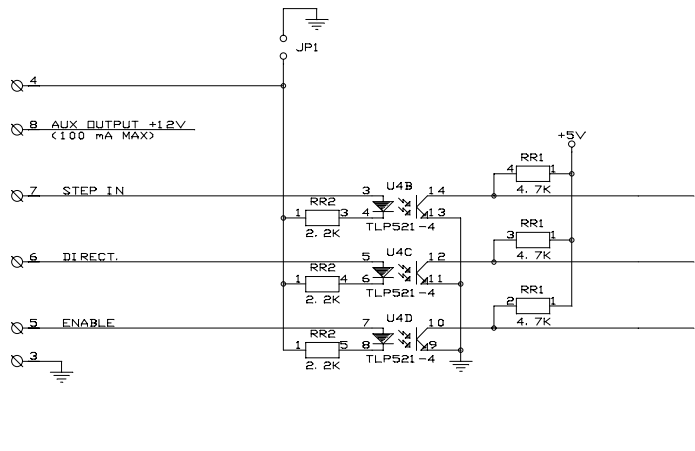

NPN version (Micro-2-NS1)

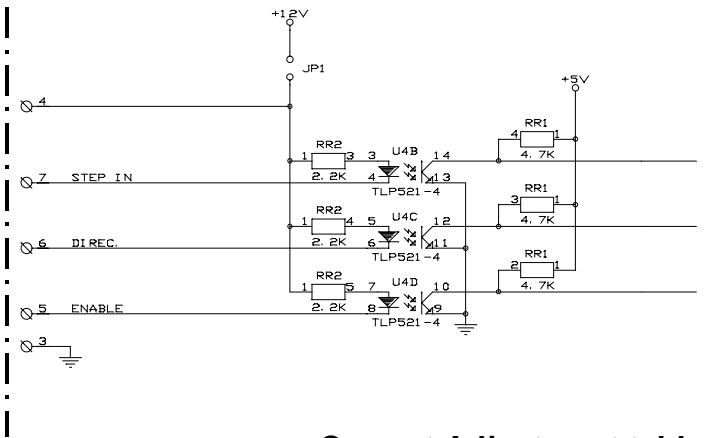

Current Adjustment

- The current is adjusted using potentiometer RV1.
- Attach a voltmeter or an oscilloscope (measuring range VDC) at the test points TP1 and TP2.
- Set the DIP switch '4' to 'OFF' then switch the voltage on and on the basis of the table on the right, adjust the current by setting the equivalent in mV voltage.
- After adjustment switch the voltage off and set DIP switch 4 to the 'ON' position.
- The module is now ready for use.

Current Adjustment table

mV	I (A)
50	0.1
100	0.2
200	0.4
300	0.6
400	0.8
500	1.0
600	1.2
700	1.4
800	1.7
900	1.9
1000	2.1
1100	2.3
1175	2.4

'Ready for use' indication

If the output stage is 'ready for use' the LED 1 will be lit up.

Temperature protection

If the Temperature protection is activated, the LED 1 flashes and deactivates the output stage. The output stage is reactivated, if the normal temperature is again achieved.

Versions:

MICRO 2 inputs switching with PNP: Type No.: **MICRO-2-PS1**

MICRO 2 inputs switching with NPN: Type No.: **MICRO-2-NS1**

ACP&D Limited

Unit 9a, Charlestown Industrial Estate
 Robinson Street, Ashton-under-Lyne
 Lancashire, OL6 8NS.
 Tel: +44 (0)161 343 1884
 Fax: +44 (0)161 339 0650